

Model name:

MMY-MAP_6HT8P-E

MMY-SAP_6HT8P-E

SMMS
SUPER MODULAR MULTI SYSTEM



**Engineering
Data Book**

< Full version >

Notice: Toshiba is committed to continuously improving its products to ensure the highest quality and reliability standards, and to meet local regulations and market requirements. All features and specifications are subject to change without prior notice.









	Safety caution	2
1	System overview	5
	1-1. Allocation standard of model name	5
	1-2. Summary of system equipments	6
2	Equipment selection procedure	11
	2-1. Selection flow chart.....	11
	2-2. Combination conditions for indoor unit and outdoor unit	12
	2-3. Cooling/heating capacity characteristics.....	12
	2-4. Operational temperature range.....	18
3	Refrigerant piping design.....	19
	3-1. Free branching system	19
	3-2. Allowable length/height difference of refrigerant piping	20
	3-3. Selection of refrigerant piping	21
	3-4. Charging requirement with additional refrigerant	22
4	Wiring design.....	23
	4-1. General	23
	4-2. Summary of wiring design	23
	4-3. Electrical wiring design	23
	4-4. Outdoor unit power supply	24
	4-5. Indoor unit power supply.....	26
	4-6. Design of control wiring	29
5	Outdoor unit.....	31
	5-1. Specifications.....	31
	5-2. Dimensional drawing	42
	5-3. Center of gravity.....	56
	5-4. Branch header / Branch joint.....	57
	5-5. Refrigerant cycle diagram.....	60
	5-6. Wiring diagram.....	63
	5-7. Connecting diagram.....	66
	5-8. Applied control for Outdoor Unit	69
	5-9. Optional printed circuit board (PCB) of outdoor unit.....	72
	5-10. Part load performance.....	80
	5-11. Sound pressure level data.....	115



- Before use, read carefully through the “Safety caution” section to ensure correct operation.
- The important contents concerned to the safety are described in the “Safety cautions”. Be sure to keep them. For Indications and their meanings, see the following description.

■ Warning Indications on the Air Conditioner Unit

Warning indication		Description
	<p>WARNING</p> <p>ELECTRICAL SHOCK HAZARD Disconnect all remote electric power supplies</p>	<p>WARNING</p> <p>ELECTRICAL SHOCK HAZARD Disconnect all remote electric power supplies before servicing.</p>
	<p>WARNING</p> <p>Moving parts. Do not operate unit with grille removed.</p>	<p>WARNING</p> <p>Moving parts. Do not operate unit with grille removed. Stop the unit before the servicing.</p>
	<p>CAUTION</p> <p>High temperature parts. You might get burned when removing this panel.</p>	<p>CAUTION</p> <p>High temperature parts. You might get burned when removing this panel.</p>
	<p>CAUTION</p> <p>Do not touch the aluminum fins of the unit. Doing so may result in injury.</p>	<p>CAUTION</p> <p>Do not touch the aluminium fins of the unit. Doing so may result in injury.</p>
	<p>CAUTION</p> <p>BURST HAZARD Open the service valves before the operation,</p>	<p>CAUTION</p> <p>BURST HAZARD Open the service valves before the operation, otherwise there might be the burst.</p>
	<p>CAUTION</p> <p>Do not climb onto the fan guard. Doing so may result in</p>	<p>CAUTION</p> <p>Do not climb onto the fan guard. Doing so may result in injury.</p>

■ Explanation of indications

⚠ WARNING

Indicates possibilities that a death or serious injury of personnel is caused by an incorrect handling.

⚠ CAUTION

Indicates contents that an injury (*1) or property damage (*2) only may be caused when an incorrect work has been executed.

*1: "Injury" means a hurt, a burn, or an electric shock which does not require hospitalization or a long-term going to the hospital.

*2: "Property damage means an enlarged damage concerned to property, or breakage of materials.

- **After installation work has finished, check there is no trouble by a test operation, and explain using method and maintenance method to the customers based on the Owner's Manual.**

Please ask the customers to keep this Installation Manual together with the Owner's Manual.

⚠ WARNING

Ask a shop or a professional dealer to install the air conditioner.

If you will install by yourself, a fire, an electric shock, or water leak is caused.

Take measures so that the refrigerant does not exceed the limit concentration even if it leaks when installing the air conditioner in a small room.

For the measures not to exceed the limit of concentration, contact the dealer. If the refrigerant leaks and it exceeds the limit of concentration, an accident of oxygen shortage is caused.

Install the air conditioner at a place which is satisfactorily bearable to weight.

If strength is insufficient, the unit may fall down resulting in human injury.

Perform a specified installation work against a strong wind such as typhoon or earthquake.

If the air conditioner is imperfectly installed, an accident by falling or dropping may be caused.

If refrigerant gas leaks during installation work, ventilate the room.

If the leaked refrigerant gas approaches to fire, noxious gas may generate.

After installation work, confirm that refrigerant gas does not leak.

If refrigerant gas leaks in the room, and approaches to fire such as fan heater, stove or kitchen range, generation of noxious gas may be caused.

Never recover refrigerant in the outdoor unit.

Be sure to use a refrigerant recovery device to recover refrigerant in reinstallation or repair work.

Recovery of refrigerant in the outdoor unit is unavailable; otherwise a serious accident such as crack or human injury is caused.

A person qualified for the electric work should deal with the electric construction conforming to the regulations of the local electric company and the Installation Manual. Be sure to use the exclusive circuit.

If there is capacity shortage of the power supply circuit or incomplete installation, a fire or an electric shock is caused.

For cabling, use the specified cables and connect them securely so that external force of cable does not transmit to the terminal connecting section.

If connection or fixing is incomplete, a fire, etc. may be caused.

Be sure to connect earth wire.

Do not connect earth wire to gas pipe, water pipe, lightning rod, nor earth wire of telephone.

If grounding is incomplete, an electric shock is caused.

⚠ CAUTION

Do not install the air conditioner at a place where combustible gas may leak.

If gas leaks and is collected at surrounding the unit, the production of fire may be caused.

Be sure to attach an earth leakage breaker; otherwise an electric shock may be caused.

Using a torque wrench, tighten the flare nut in the specified method.

If the flare nut is exceedingly tightened, the flare nut is broken and a refrigerant leakage may be caused after a long time has passed.

WARNINGS ON REFRIGERANT LEAKAGE

Check of Concentration Limit

The room in which the air conditioner is to be installed requires a design that in the event of refrigerant gas leaking out, its concentration will not exceed a set limit.

The refrigerant R410A which is used in the air conditioner is safe, without the toxicity or combustibility of ammonia, and is not restricted by laws to be imposed which protect the ozone layer. However, since it contains more than air, it poses the risk of suffocation if its concentration should rise excessively.

Suffocation from leakage of R410A is almost nonexistent. With the recent increase in the number of high concentration buildings, however, the installation of multi air conditioner systems is on the increase because of the need for effective use of floor space, individual control, energy conservation by curtailing heat and carrying power etc.

Most importantly, the multi air conditioner system is able to replenish a large amount of refrigerant compared with conventional individual air conditioners. If a single unit of the multi conditioner system is to be installed in a small room, select a suitable model and installation procedure so that if the refrigerant accidentally leaks out, its concentration does not reach the limit (and in the event of an emergency, measures can be made before injury can occur).

In a room where the concentration may exceed the limit, create an opening with adjacent rooms, or install mechanical ventilation combined with a gas leak detection device.

The concentration is as given below.

$$\frac{\text{Total amount of refrigerant (kg)}}{\text{Min. volume of the indoor unit installed room (m}^3\text{)}} \leq \text{Concentration limit (kg/m}^3\text{)}$$

Concentration limit

Compliance to the local applicable regulations and standards for the concentration limit is required.

NOTE 1:

If there are 2 or more refrigerating systems in a single refrigerating device, the amounts of refrigerant should be as charged in each independent device.

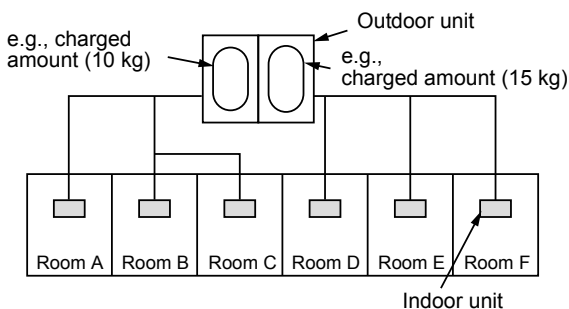

For the amount of charge in this example:

The possible amount of leaked refrigerant gas in rooms A, B and C is 10 kg.

The possible amount of leaked refrigerant gas in rooms D, E and F is 15 kg.

Important

NOTE 2:

The standards for minimum room volume are as follows.

- (1) No partition (shaded portion)

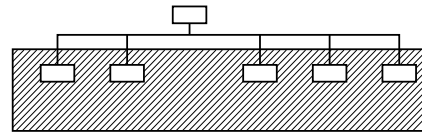

- (2) When there is an effective opening with the adjacent room for ventilation of leaking refrigerant gas (opening without a door, or an opening 0.15 % or larger than the respective floor spaces at the top or bottom of the door).

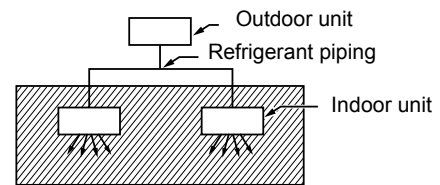

- (3) If an indoor unit is installed in each partitioned room and the refrigerant tubing is interconnected, the smallest room of course becomes the object. But when a mechanical ventilation is installed interlocked with a gas leakage detector in the smallest room where the density limit is exceeded, the volume of the next smallest room becomes the object.

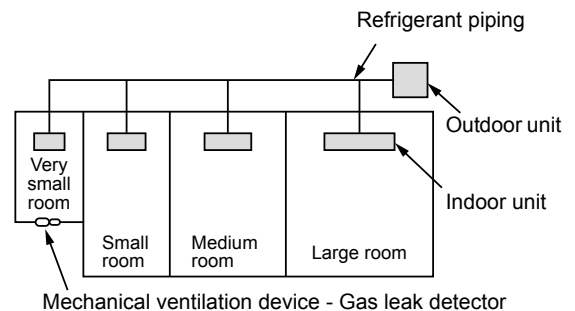



1-1. Allocation standard of model name SMMS-e

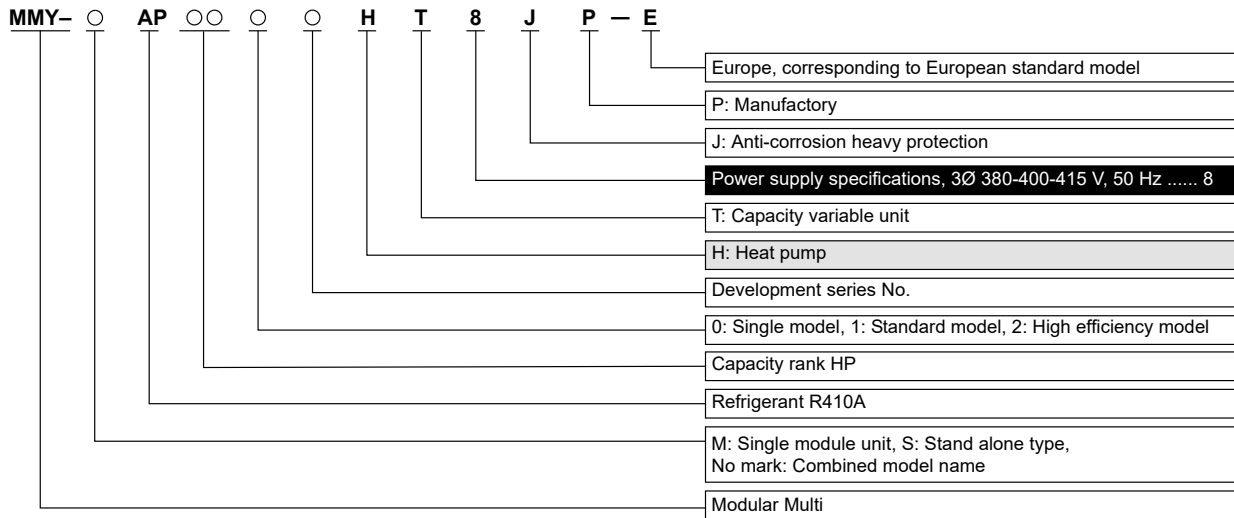



1-2. Summary of system equipments

1-2-1. Outdoor units

Corresponding HP			Standard type							
			8HP	10HP	12HP	14HP	16HP	18HP	20HP	22HP
Model name	Heat pump	MMY-	MAP0806HT8P-E	MAP1006HT8P-E	MAP1206HT8P-E	MAP1406HT8P-E	MAP1606HT8P-E	MAP1806HT8P-E	MAP2006HT8P-E	MAP2206HT8P-E
Cooling capacity (kW)			22.4	28.0	33.5	40.0	45.0	50.4	56.0	61.5
Heating capacity (kW)			25.0	31.5	37.5	45.0	50.0	56.0	63.0	64.0
No. of connectable indoor units			18	22	27	31	36	40	45	49

Corresponding HP			Stand alone type *		
			8HP	10HP	12HP
Model name	Heat pump	MMY-	SAP0806HT8P-E	SAP1006HT8P-E	SAP1206HT8P-E
Cooling capacity (kW)			22.4	28.0	33.5
Heating capacity (kW)			25.0	31.5	37.5
No. of connectable indoor units			18	22	27

* Stand alone type is the type that can reduce the amount of refrigerant below normal. It is only single unit system without outdoor connection. Hot water module and Air to air heat exchanger can't be connected.

■ Combination of outdoor units

Standard model

Corresponding HP			24HP	26HP	28HP	30HP	32HP	34HP	36HP	38HP
Combined Model	MMY-		AP2416HT8P-E	AP2616HT8P-E	AP2816HT8P-E	AP3016HT8P-E	AP3216HT8P-E	AP3416HT8P-E	AP3616HT8P-E	AP3816HT8P-E
Cooling capacity (kW)			67.0	73.5	78.5	85.0	90.0	95.4	101.0	106.5
Heating capacity (kW)			75.0	82.5	87.5	95.0	100.0	106.0	113.0	114.0
Combined outdoor units			12HP	14HP	16HP	16HP	16HP	18HP	20HP	22HP
			12HP	12HP	12HP	14HP	16HP	16HP	16HP	16HP
No. of connectable indoor units			54	58	63	64	64	64	64	64

Corresponding HP			40HP	42HP	44HP	46HP	48HP	50HP	52HP	54HP
Combined Model	MMY-		AP4016HT8P-E	AP4216HT8P-E	AP4416HT8P-E	AP4616HT8P-E	AP4816HT8P-E	AP5016HT8P-E	AP5216HT8P-E	AP5416HT8P-E
Cooling capacity (kW)			112.0	117.5	123.0	130.0	135.0	140.4	146.0	151.5
Heating capacity (kW)			126.0	127.0	128.0	145.0	150.0	156.0	163.0	164.0
Combined outdoor units			20HP	22HP	22HP	16HP	16HP	18HP	20HP	22HP
			20HP	20HP	22HP	16HP	16HP	16HP	16HP	16HP
No. of connectable indoor units			64	64	64	64	64	64	64	64

Corresponding HP			56HP	58HP	60HP
Combined Model	MMY-		AP5616HT8P-E	AP5816HT8P-E	AP6016HT8P-E
Cooling capacity (kW)			157.0	162.5	168.0
Heating capacity (kW)			176.0	177.0	178.0
Combined outdoor units			20HP	22HP	22HP
			20HP	20HP	22HP
No. of connectable indoor units			64	64	64

High efficiency / Heating capacity priority model

Corresponding HP			20HP	22HP	36HP	38HP	40HP	42HP	44HP	54HP
Combined Model	MMY-		AP2026HT8P-E	AP2226HT8P-E	AP3626HT8P-E	AP3826HT8P-E	AP4026HT8P-E	AP4226HT8P-E	AP4426HT8P-E	AP5426HT8P-E
Cooling capacity (kW)			56.0	61.5	100.5	107.0	113.5	120.0	125.0	152.0
Heating capacity (kW)			63.0	69.0	112.5	120.0	127.5	135.0	140.0	171.0
Combined outdoor units			10HP	12HP	12HP	14HP	14HP	14HP	16HP	20HP
			10HP	10HP	12HP	12HP	14HP	14HP	14HP	14HP
No. of connectable indoor units			45	49	64	64	64	64	64	64

1-2-2. Indoor Unit

Type	Appearance	Model name	Capacity rank	Capacity Code	Cooling capacity(kW)	Heating capacity(kW)
4-way Air Discharge Cassette Type		MMU-AP0094HP1-E	009	1	2.8	3.2
		MMU-AP0124HP1-E	012	1.25	3.6	4.0
		MMU-AP0154HP1-E	015	1.7	4.5	5.0
		MMU-AP0184HP1-E	018	2	5.6	6.3
		MMU-AP0244HP1-E	024	2.5	7.1	8.0
		MMU-AP0274HP1-E	027	3	8.0	9.0
		MMU-AP0304HP1-E	030	3.2	9.0	10.0
		MMU-AP0364HP1-E	036	4	11.2	12.5
Compact 4-way Cassette (600 x 600) Type		MMU-AP0056MH1-E	005	0.6	1.7	1.9
		MMU-AP0074MH1-E	007	0.8	2.2	2.5
		MMU-AP0094MH1-E	009	1	2.8	3.2
		MMU-AP0124MH1-E	012	1.25	3.6	4.0
		MMU-AP0154MH1-E	015	1.7	4.5	5.0
		MMU-AP0184MH1-E	018	2	5.6	6.3
		MMU-AP0057MH-E	005	0.6	1.7	1.9
		MMU-AP0077MH-E	007	0.8	2.2	2.5
Compact 4-way Cassette		MMU-AP0097MH-E	009	1	2.8	3.2
		MMU-AP0127MH-E	012	1.25	3.6	4.0
		MMU-AP0157MH-E	015	1.7	4.5	5.0
		MMU-AP0187MH-E	018	2	5.6	6.3
		MMU-AP0072WH1	007	0.8	2.2	2.5
		MMU-AP0092WH1	009	1	2.8	3.2
		MMU-AP0122WH1	012	1.25	3.6	4.0
		MMU-AP0152WH1	015	1.7	4.5	5.0
2-way Air Discharge Cassette Type		MMU-AP0182WH1	018	2	5.6	6.3
		MMU-AP0242WH1	024	2.5	7.1	8.0
		MMU-AP0272WH1	027	3	8.0	9.0
		MMU-AP0302WH1	030	3.2	9.0	10.0
		MMU-AP0362WH1	036	4.0	11.2	12.5
		MMU-AP0482WH1	048	5.0	14.0	16.0
		MMU-AP0562WH1	056	6	16.0	18.0
		MMU-AP0074YH1-E	007	0.8	2.2	2.5
1-way Air Discharge Cassette Type		MMU-AP0094YH1-E	009	1.0	2.8	3.2
		MMU-AP0124YH1-E	012	1.25	3.6	4.0
		MMU-AP0154SH1-E	015	1.7	4.5	5.0
		MMU-AP0184SH1-E	018	2.0	5.6	6.3
		MMU-AP0244SH1-E	024	2.5	7.1	8.0
Concealed Duct Type		MMD-AP0076BHP1-E	007	0.80	2.2	2.5
		MMD-AP0096BHP1-E	009	1.00	2.8	3.2
		MMD-AP0126BHP1-E	012	1.25	3.6	4.0
		MMD-AP0156BHP1-E	015	1.70	4.5	5.0
		MMD-AP0186BHP1-E	018	2.00	5.6	6.3
		MMD-AP0246BHP1-E	024	2.50	7.1	8.0
		MMD-AP0276BHP1-E	027	3.00	8.0	9.0
		MMD-AP0306BHP1-E	030	3.20	9.0	10.0
		MMD-AP0366BHP1-E	036	4.00	11.2	12.5
		MMD-AP0486BHP1-E	048	5.00	14.0	16.0
Slim Duct Type		MMD-AP0566BHP1-E	056	6.00	16.0	18.0
		MMD-AP0056SPH1-E	005	0.6	1.7	1.9
		MMD-AP0074SPH1-E	007	0.80	2.2	2.5
		MMD-AP0094SPH1-E	009	1.00	2.8	3.2
		MMD-AP0124SPH1-E	012	1.25	3.6	4.0
		MMD-AP0154SPH1-E	015	1.70	4.5	5.0
		MMD-AP0184SPH1-E	018	2.00	5.6	6.3
		MMD-AP0244SPH1-E	024	2.25	7.1	8.0
Concealed Duct High Static Pressure Type		MMD-AP0274SPH1-E	027	3.0	8.0	9.0
		MMD-AP0186HP1-E	018	2.0	5.6	6.3
		MMD-AP0246HP1-E	024	2.5	7.1	8.0
		MMD-AP0276HP1-E	027	3.0	8.0	9.0
		MMD-AP0366HP1-E	036	4.0	11.2	12.5
		MMD-AP0486HP1-E	048	5.0	14.0	16.0
		MMD-AP0566HP1-E	056	6.0	16.0	18.0
		MMD-AP0726HP-E	072	8.0	22.4	25.0
Under Ceiling Type		MMD-AP0966HP-E	096	10.0	28.0	31.5
		MMC-AP0158HP-E	015	1.7	4.5	5.0
		MMC-AP0188HP-E	018	2.0	5.6	6.3
		MMC-AP0248HP-E	024	2.5	7.1	8.0
		MMC-AP0278HP-E	027	3.0	8.0	9.0
		MMC-AP0368HP-E	036	4.0	11.2	12.5
MMC-AP0488HP-E	048	5.0	14.0	16.0		
MMC-AP0568HP-E	056	6.0	16.0	18.0		

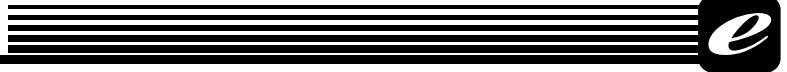

Indoor Unit

Type	Appearance	Model name	Capacity rank	Capacity Code	Cooling capacity(kW)	Heating capacity(kW)
High Wall Type 3 series		MMK-AP0073H1	007	0.8	2.2	2.5
		MMK-AP0093H1	009	1.0	2.8	3.2
		MMK-AP0123H1	012	1.25	3.6	4.0
		MMK-AP0153H1	015	1.70	4.5	5.0
		MMK-AP0183H1	018	2.00	5.6	6.3
		MMK-AP0243H1	024	2.50	7.1	8.0
High Wall Type 3 series (Without PMV)		MMK-AP0073HP1-E1	007	0.8	2.2	2.5
		MMK-AP0093HP1-E1	009	1.0	2.8	3.2
		MMK-AP0123HP1-E1	012	1.25	3.6	4.0
		MMK-AP0153HP1-E1	015	1.70	4.5	5.0
		MMK-AP0183HP1-E1	018	2.00	5.6	6.3
		MMK-AP0243HP1-E1	024	2.50	7.1	8.0
High Wall Type 7 series		MMK-AP0057HP-E	005	0.6	1.7	1.9
		MMK-AP0077HP-E	007	0.8	2.2	2.5
		MMK-AP0097HP-E	009	1	2.8	3.2
		MMK-AP0127HP-E	012	1.25	3.6	4.0
		MMK-AP0157HP-E	015	1.7	4.5	5.0
		MMK-AP0187HP-E	018	2.0	5.6	6.3
High Wall Type 7 series (Without PMV)		MMK-AP0057HP-E1	005	0.6	1.7	1.9
		MMK-AP0077HP-E1	007	0.8	2.2	2.5
		MMK-AP0097HP-E1	009	1	2.8	3.2
		MMK-AP0127HP-E1	012	1.25	3.6	4.0
		MMK-AP0157HP-E1	015	1.7	4.5	5.0
		MMK-AP0187HP-E1	018	2.0	5.6	6.3
Floor Standing Concealed Type		MML-AP0074BH1-E	007	0.8	2.2	2.5
		MML-AP0094BH1-E	009	1	2.8	3.2
		MML-AP0124BH1-E	012	1.25	3.6	4.0
		MML-AP0154BH1-E	015	1.7	4.5	5.0
		MML-AP0184BH1-E	018	2	5.6	6.3
		MML-AP0244BH1-E	024	2.5	7.1	8.0
Floor Standing Cabinet Type		MML-AP0074H1-E	007	0.8	2.2	2.5
		MML-AP0094H1-E	009	1	2.8	3.2
		MML-AP0124H1-E	012	1.25	3.6	4.0
		MML-AP0154H1-E	015	1.7	4.5	5.0
		MML-AP0184H1-E	018	2	5.6	6.3
		MML-AP0244H1-E	024	2.5	7.1	8.0
Floor Standing Type		MMF-AP0156H1-E	015	1.7	4.5	5.0
		MMF-AP0186H1-E	018	2	5.6	6.3
		MMF-AP0246H1-E	024	2.5	7.1	8.0
		MMF-AP0276H1-E	027	3	8.0	9.0
		MMF-AP0366H1-E	036	4	11.2	12.5
		MMF-AP0486H1-E	048	5	14.0	16.0
Hot Water Module *2		MMW-AP0271LQ-E	027	3	-	8.0
		MMW-AP561LQ-E	056	6	-	16.0
Console Type		MML-AP0074NH1-E	007	0.8	2.2	2.5
		MML-AP0094NH1-E	009	1	2.8	3.2
		MML-AP0124NH1-E	012	1.3	3.6	4.0
		MML-AP0154NH1-E	015	1.7	4.5	5.0
		MML-AP0184NH1-E	018	2.0	5.6	6.3
Fresh Air Intake Indoor unit Type *2		MMD-AP0481HFE	048	5.0	14.0	8.9
		MMD-AP0721HFE	072	8.0	22.4	13.9
		MMD-AP0961HFE	096	10.0	28.0	17.4
Air to Air Heat exchanger with DX-coil Type *2		MMD-VN502HEX1E	009	1	4.10(1.30) ^{*1}	5.53(2.33) ^{*1}
		MMD-VN802HEX1E	015	1.7	6.56(2.06) ^{*1}	8.61(3.61) ^{*1}
		MMD-VN1002HEX1E	018	2	8.25(2.32) ^{*1}	10.92(4.32) ^{*1}
Air to Air Heat exchanger with DX-coil Humidifier Type *2		MMD-VNK502HEX1E	009	1	4.10(1.30) ^{*1}	5.53(2.33) ^{*1}
		MMD-VNK802HEX1E	015	1.7	6.56(2.06) ^{*1}	8.61(3.61) ^{*1}
		MMD-VNK1002HEX1E	018	2	8.25(2.32) ^{*1}	10.92(4.32) ^{*1}

*1 : The figures in () indicate the heat reclaimed from the heat recovery ventilator.

*2 : This indoor unit can't be connected to the Stand alone type(MMY-SAP**6HT8P-E).

1-2-3. Branching joints and headers

Name	Model name	Appearance
Y-shape branching joint	RBM-BY55E	
	RBM-BY105E	
	RBM-BY205E	
	RBM-BY305E	
4-branching header	RBM-HY1043E	
	RBM-HY2043E	
8-branching header	RBM-HY1083E	
	RBM-HY2083E	
Branching joint for connection of outdoor units	RBM-BT14E	
	RBM-BT24E	

1-2-4. Remote controllers

Name	Model Name	Remarks
Wired remote controller	RBC-AMT32E	-EN : English, Italian, Polish, Greece, Russian, Turkish -ES : English, Spanish, Portuguese, French, Dutch, German -EN : English, Italian, Polish, Greece, Russian, Turkish -ES : English, Spanish, Portuguese, French, Dutch, German
	RBC-AMS54E-EN/ES	
	RBC-AMS55E-EN/ES	
Compact wired remote controller	RBC-ASC11E	
Simple wired remote controller	RBC-AS41E	
Wireless remote controller kit	RBC-AX32U(W)-E	For 4-way Air Discharge Cassette
	RBC-AX32U(WS)-E	For Compact 4-way Cassette 7series
	RBC-AX32UM(W)-E	
	RBC-AX33CE2	For Under Ceiling, 1-way Air Discharge Cassette SH
	TCB-AX32E2	For all other units.
	RBC-AX32UW(W)-E	For 2-way Air Discharge Cassette
ON-OFF controller	TCB-CC163TLE2	
Central remote controller	BMS-CM1280TLE	
Schedule timer	TCB-EXS21TLE	
Remote controller with schedule timer (7-day timer function)	RBC-AMS41E	
Wired remote controller for Air to Air Heat Exchanger with DX coil unit	NRC-01HE	For Air to Air Heat Exchanger with DX coil type

1-2-5. Optional PCB of outdoor unit

Name	Model Name	Remarks
Power peak-cut control board	TCB-PCDM4E	
External master ON/OFF control board	TCB-PCMO4E	
Output control board	TCB-PCIN4E	

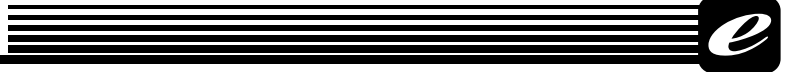
**1-2-6. Controls**

Name	Model Name	Remarks
Touch Screen Controller	BMS-CT5121E	
Smart BMS manager	BMS-SM1280HTLE	
Smart BMS manager with data analyzer	BMS-SM1281ETLE	
Relay Interface	BMS-IFLSV4E	
Energy Monitoring Relay Interface	BMS-IFWH5E	
Digital I/O Relay Interface	BMS-IFDD03E	
LonWorks LN Interface	TCB-IFLN642TLE	
Modbus Interface	TCB-IFMB641TLE BMS-IFMB0TLR-E	Use only one remote controller
Analog Interface	TCB-IFCB640TLE	
BN Interface	BMS-IFBN640TLE	



2-1. Selection flow chart

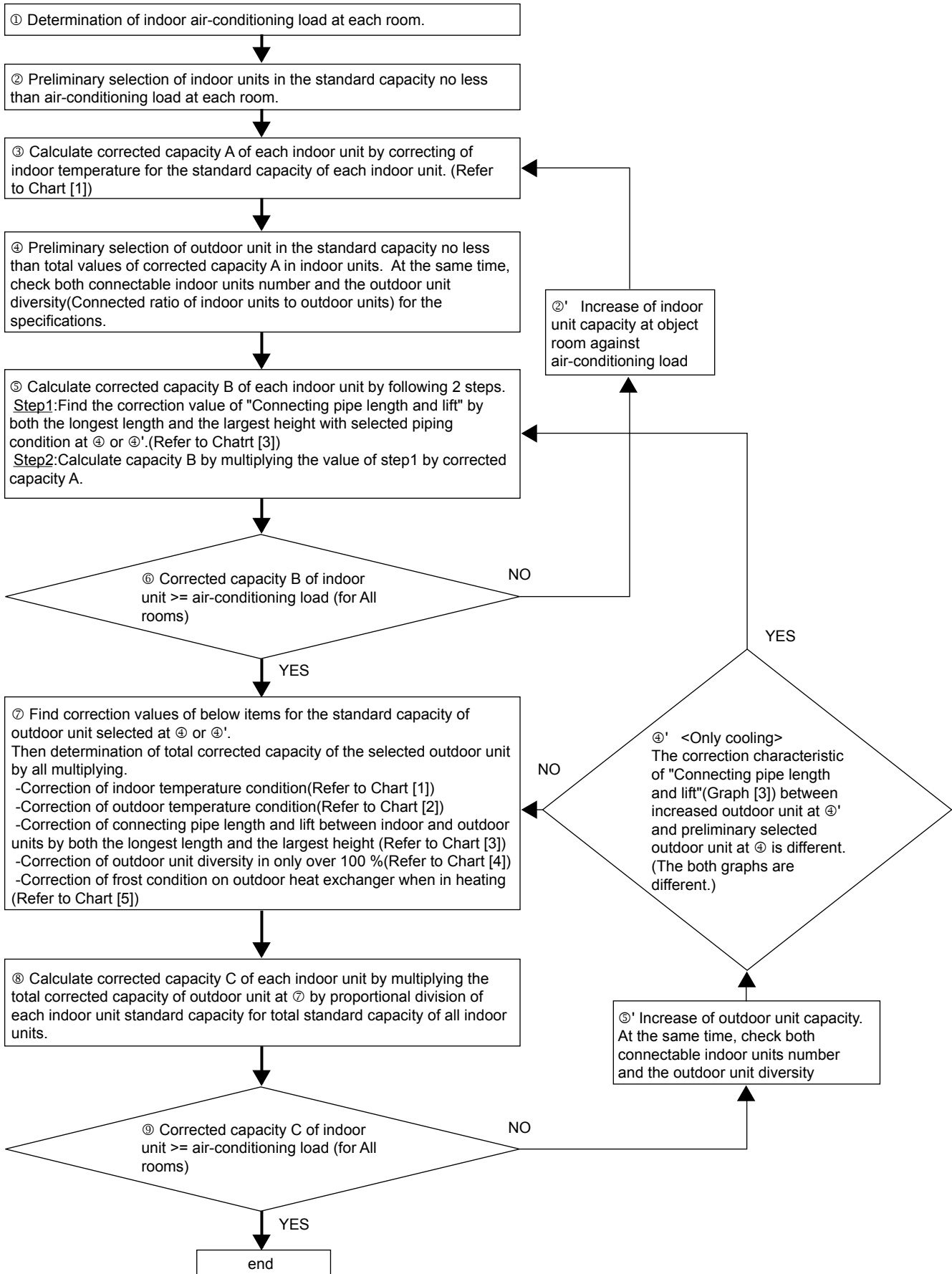



2-2. Combination conditions for indoor unit and outdoor unit

Indoor unit can connect 50 % to 135 % of Outdoor unit capacity.

NOTE:

Height difference between indoor unit over 15 m, combination conditions for indoor and outdoor unit is 50 % to 105 %.

2-3. Cooling/heating capacity characteristics

2-3-1. Correction charts for cooling capacity calculation

[1] Indoor air wet bulb temperature vs. capacity correction value

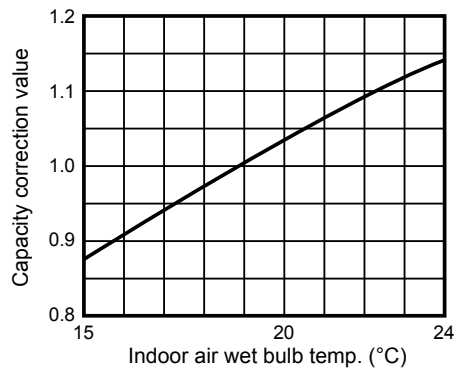

[2] Outdoor air dry bulb temperature vs. capacity correction value

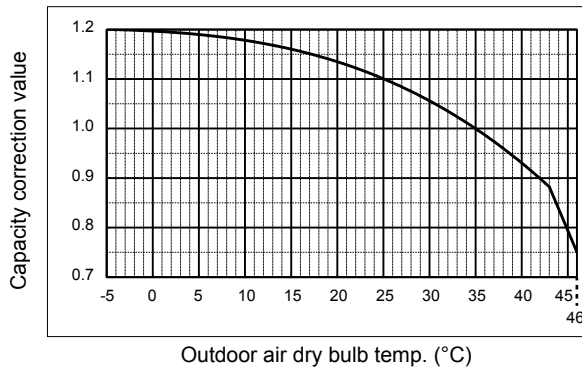

[3] Connecting pipe length and lift difference between indoor and outdoor units vs. capacity correction value

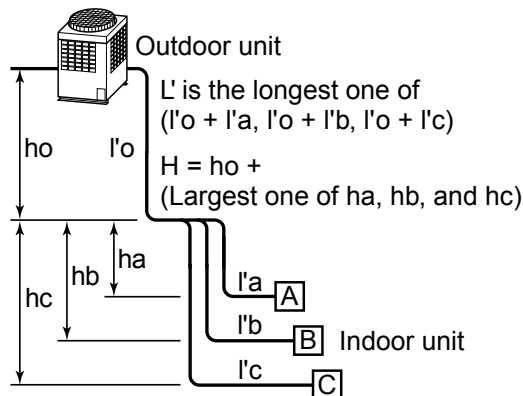

HP	Graph	EU and Asia standard		EU and Asia high efficiency	
		combination	Pipe length [m]	combination	Pipe length [m]
8	D	8	210		
10	C	10	210		
12	A	12	210		
14	A	14	210		
16	B	16	210		
18	C	18	210		
20	C	20	210	10+10	220
22	C	22	210	12+10	220
24	A	12+12	220		
26	B	14+12	220		
28	B	16+12	220		
30	B	16+14	220		
32	C	16+16	220		
34	C	18+16	220		
36	A	20+16	220	12+12+12	235
38	A	22+16	220	14+12+12	235
40	B	20+20	220	14+14+12	235
42	B	22+20	220	14+14+14	235
44	B	22+22	220	16+14+14	235
46	B	16+16+14	185		
48	C	16+16+16	185		
50	C	18+16+16	185		
52	C	20+16+16	185		
54	E	22+16+16	185	20+20+14	185
56	E	20+20+16	185		
58	E	22+20+16	185		
60	E	22+22+16	185		

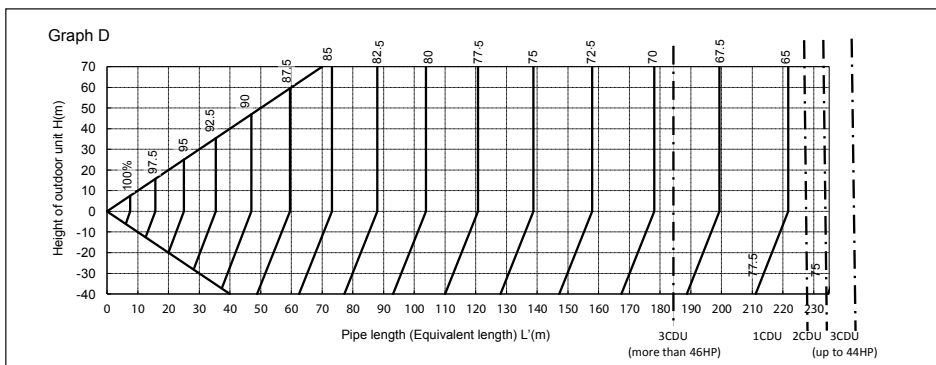
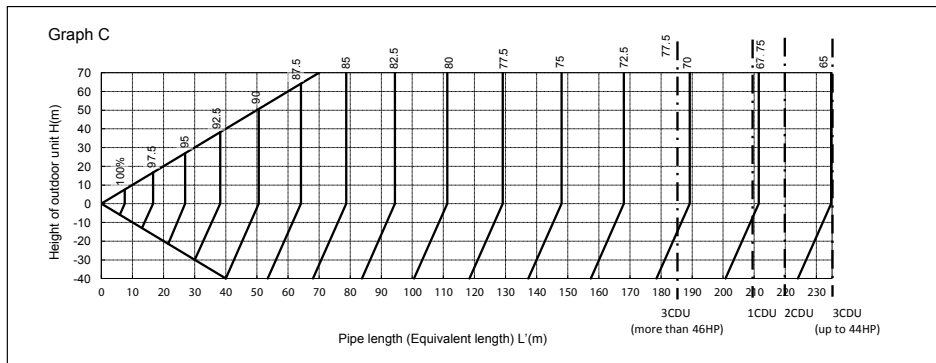
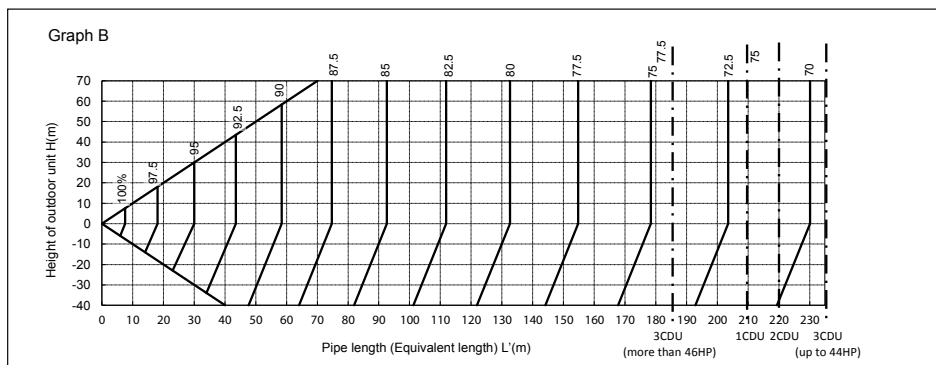
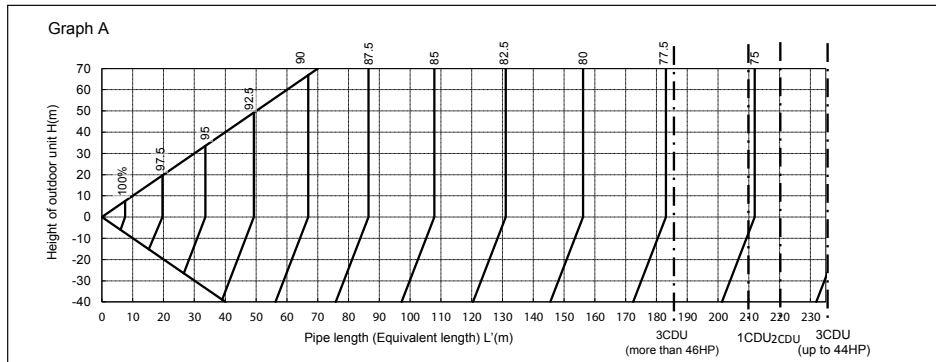

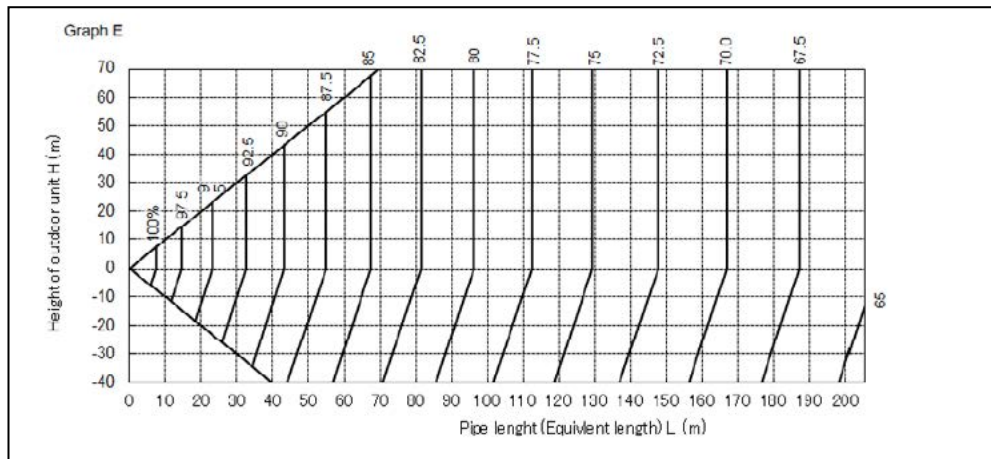

[4]* Correction of outdoor unit diversity

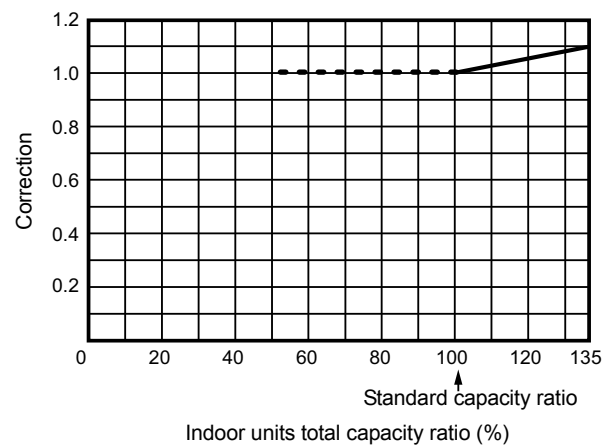

*: Coefficient to use for the correction of the outdoor unit capacity when the total capacity of the indoor units are not equal to the outdoor unit capacity.

2-3-2. Correction charts for heating capacity calculation

[1] Indoor air dry bulb temperature vs. capacity correction value

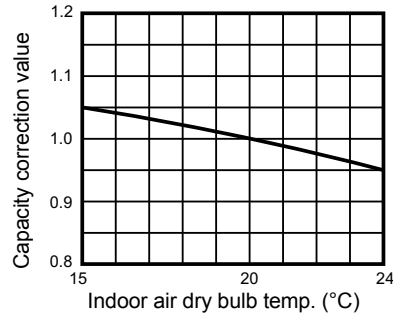

[2] Outdoor air wet bulb temperature vs. capacity correction value

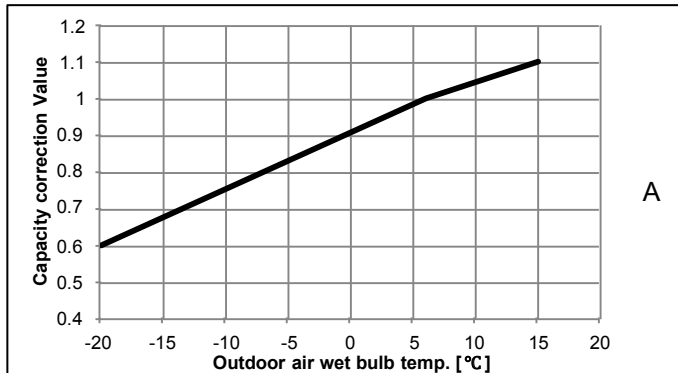

A

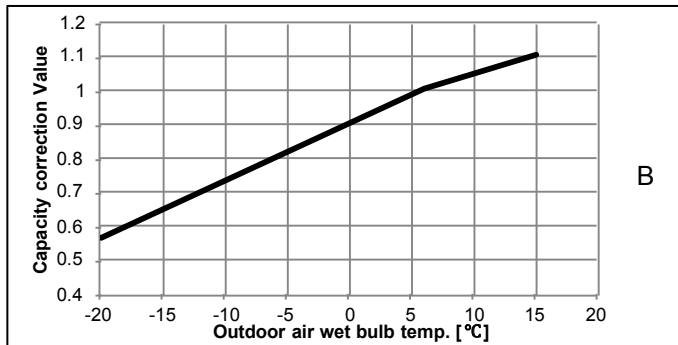

B

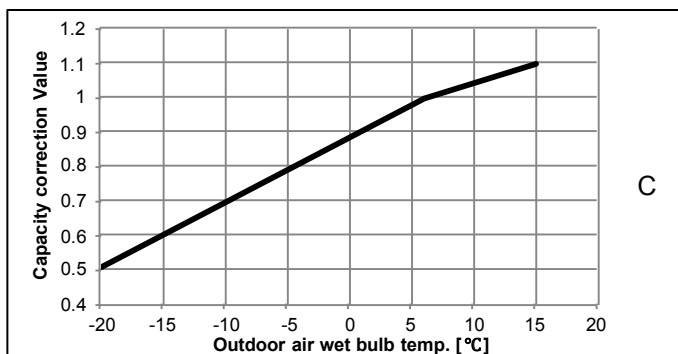

C

Standard model

HP	combination	Graph
8	8	A
10	10	B
12	12	C
14	14	B
16	16	C
18	18	B
20	20	C
22	22	C
24	12+12	C
26	14+12	C
28	16+12	C
30	16+14	C
32	16+16	C
34	18+16	C
36	20+16	C
38	22+16	C
40	20+20	C
42	22+20	C
44	22+22	C
46	16+16+14	C
48	16+16+16	C
50	18+16+16	C
52	20+16+16	C
54	22+16+16	C
56	20+20+16	C
58	22+20+16	C
60	22+22+16	C

High efficiency model

HP	combination	Graph
20	10+10	B
22	12+10	C
36	12+12+12	C
38	14+12+12	C
40	14+14+12	B
42	14+14+14	B
44	16+14+14	B
54	20+20+14	C



2-3-2. Correction charts for heating capacity calculation

[3] Connecting pipe length and lift difference between indoor and outdoor units vs. capacity correction value

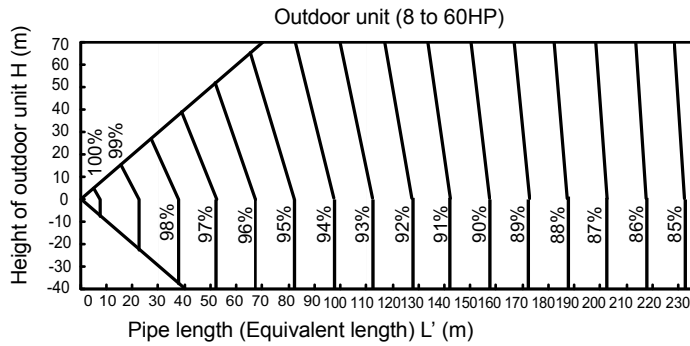
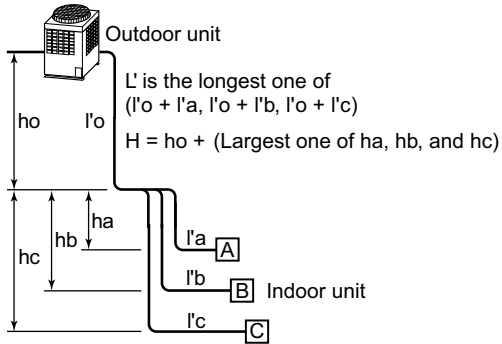



[4]* Correction of outdoor unit diversity

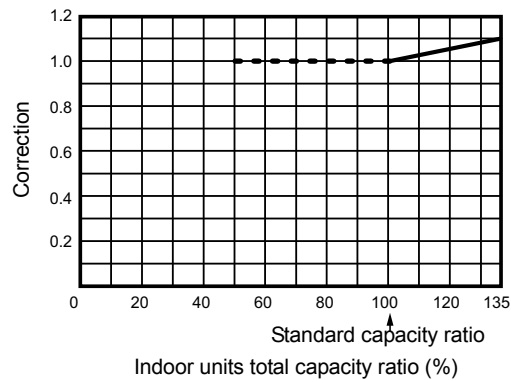

*: Coefficient to use for the correction of the outdoor unit capacity when the total capacity of the indoor units are not equal to the outdoor unit capacity.

2-3-3. Capacity correction in case of frost on the outdoor heat exchanger when in heating

Correct the heating capacity when frost can be found on the outdoor heat exchanger.

Heating capacity = Capacity after correction of outdoor unit x Correction value of capacity resulted from frost
 (Capacity after correction of outdoor unit: Heating capacity calculated in the above item 2.)

[5] Capacity correction in case of frost on the outdoor heat exchanger

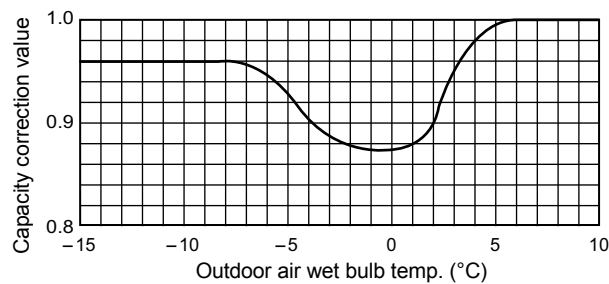

2-3-4. Rated conditions

Cooling: Indoor air temperature 27 °C DB / 19 °C WB, Outdoor air temperature 35 °C DB

Heating: Indoor air temperature 20 °C DB, Outdoor air temperature 7 °C DB / 6 °C WB

2-4. Operational temperature range

Cooling

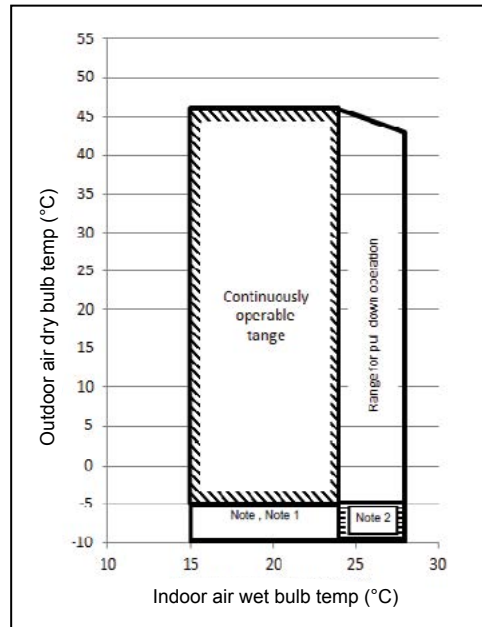

Note

1. NOT SUITABLE FOR APPLICATIONS, WHICH REQUIRE PRECISE ROOM TEMPERATURE CONTROL, DUE TO INCREASED RISK OF INDOOR ON/OFF CONTROL AND POTENTIAL LOW AIR OFF TEMPERATURES.
2. FOR AREAS THAT DO DEMAND A PRECISE ROOM TEMPERATURE CONTROL, WE WOULD RECOMMEND THE INSTALLTION OF A SECONDARY SYSTEM, WHICH HAS BEEN DESIGNED SOLELY FOR THE PURPOSE OF LOW AMBIENT COOLING.
3. SINGLE OUTDOOR UNIT ONLY.
4. NO HEIGHT DIFFERENCE BETWEEN UNITS.
5. THE COOLING PERFORMANCE MAY DECLINE CONSIDERABLY WHEN TOTAL OPERATING CAPACITY OF COOLING INDOOR UNITS IS LESS THAN 4HP WHILE AMBIENT TEMPERATURE IS BELOW -5 C.

Heating

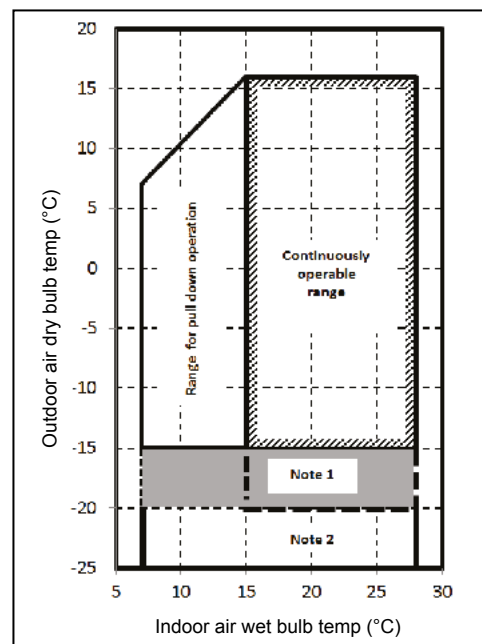

Note 1: The unit will operate down to an outdoor temperature of -25°C, however considerable performance decrease will be expected below -15°C. Therefore please consider installation location/surroundings and system design when expected to operate between -15°C and -20°C.

Note 2: Low ambient heating (-20°C or less) for extended periods of time is not allowed .



3-1. Free branching system

- [1] Line branching system
- [2] Header branching system
- [3] Header branching system after line branching
- [4] Line branching system after header branching
- [5] Header branching system after header branching

The above five branching systems enable to dramatically increase the flexibility of refrigerant piping design.

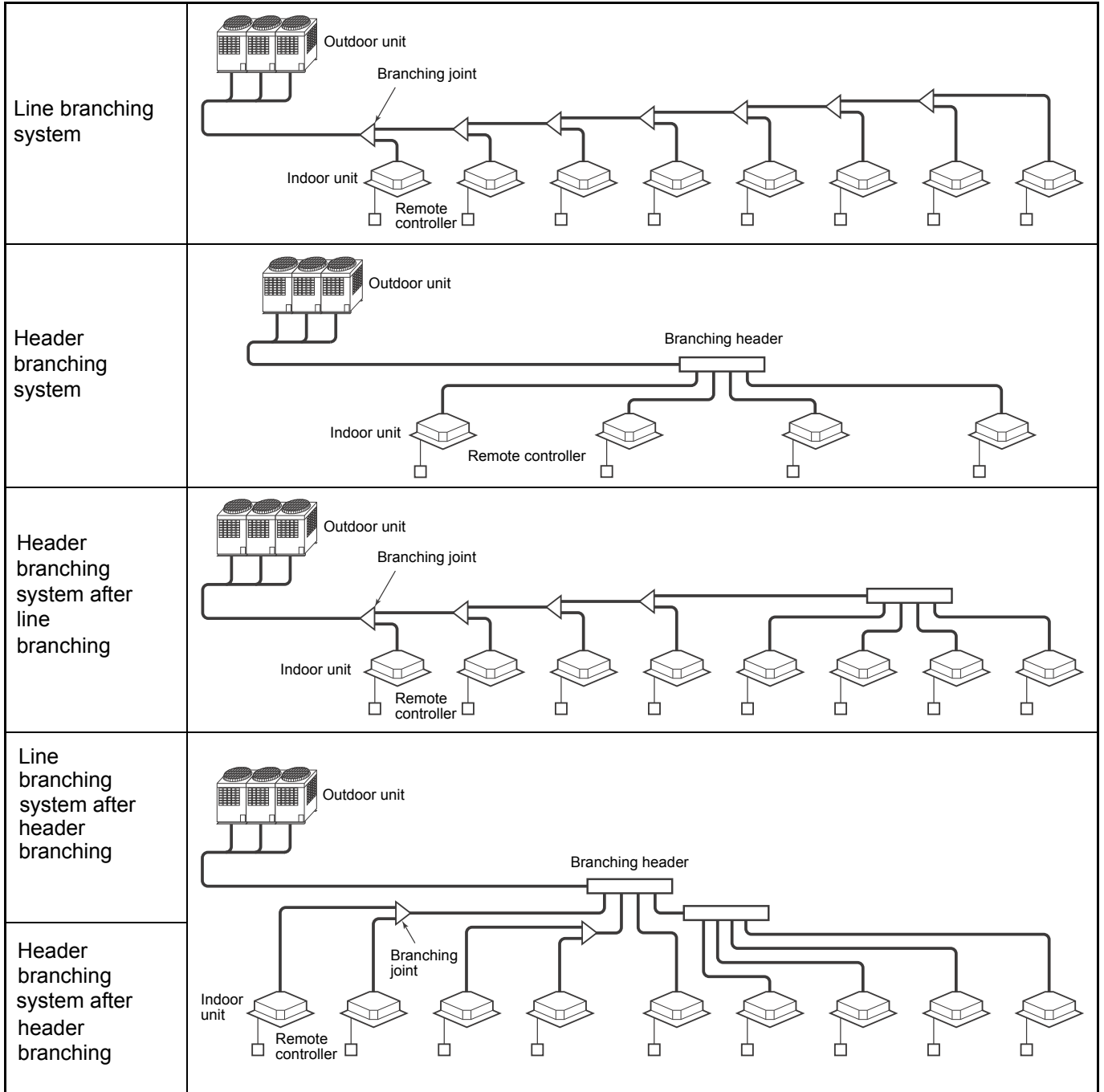



3-2. Allowable length/height difference of refrigerant piping

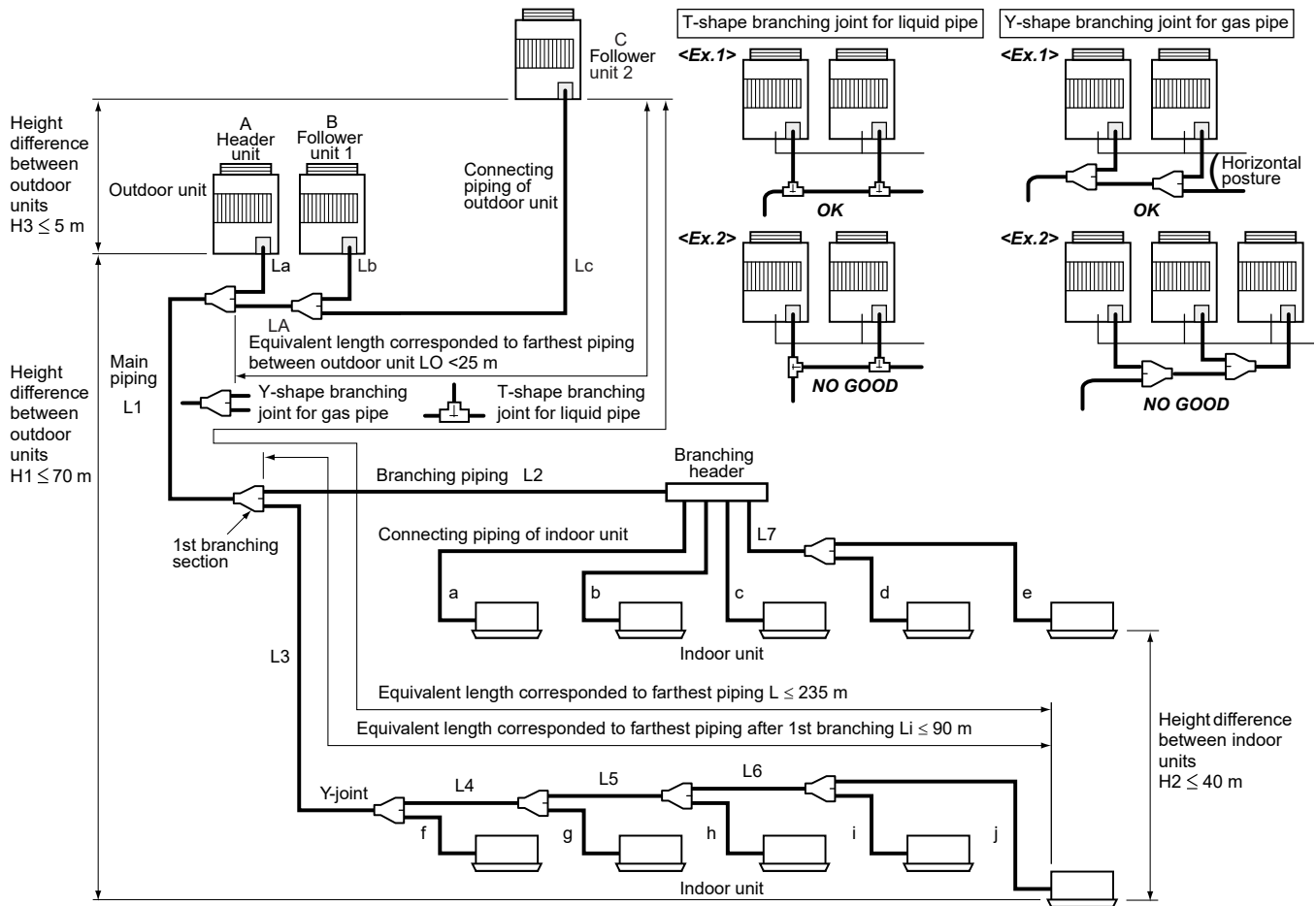

System restrictions

	Standard model	Stand alone model
Max. No. of combined outdoor units	3 units	1 units
Max. capacity of combined outdoor units	60 HP	12 HP
Max. No. of connected indoor units	64 units	27 units
Max. capacity of combined indoor units	H2 ≤ 15	135 %
	H2 > 15	105 %

- Note 1)** Combination of outdoor units: Header unit (1 unit) + Follower units (0 to 2 units). Header unit is the outdoor unit nearest to the connected indoor units.
- Note 2)** Install the outdoor units in order of capacity. (Header unit ≥ Follower unit 1 ≥ Follower unit 2)
- Note 3)** Use Y-shape branching joint in connecting of gas pipe for outdoor unit, and install horizontally.
- Note 4)** Piping to indoor units shall be perpendicular to piping to the header outdoor unit as <Ex.1>. Do not connect piping to indoor units in the same direction of header outdoor unit as T-shape branching joint for liquid pipe of <Ex.2>.

Farthest piping length L(*1) by capacity of outdoor units

Capacity (HP)	Standard model, Stand alone model				High efficiency model		
	8 ~ 22	24 ~ 44	46 ~ 52	54 ~ 60	20 ~ 22	36 ~ 44	54
Equivalent length (m)	210	220	185	185	220	235	185
Real length (m)	170	180	145	145	180	190	145

Note: All values of above table decrease 25 m when H1 exceeds 3 m.

Allowable length and height difference of refrigerant piping

		Allowable value	Piping section	
Piping length	Total extension of pipe (Liquid pipe, real length)	Below 34HP	300 m	LA + LB + La + Lb + Lc + L1 + L2 + L3 + L4 + L5 + L6 + L7 + a + b + c + d + e + f + g + h + i + j
		34HP or more	1000 m ^(*6)	
	Farthest piping Length L (*1)	Equivalent length	235 m	LA + L1 + L3 + L4 + L5 + L6 + j
		Real length	190 m	
	Equivalent length of farthest piping from 1st branching Li (*1)		90 m ^(*2)	L3 + L4 + L5 + L6 + j
	Equivalent length of farthest piping between outdoor units LO (*1)		25 m	LA + Lc (LA + Lb)
	Max. equivalent length of main piping	Equivalent length	120 m ^(*3)	L1
		Real length	100 m ^(*3)	
	Max. equivalent length of outdoor unit connecting piping		10 m	Lc (La, Lb,)
Max. real length of indoor unit connecting piping		30 m	a, b, c, d, e, f, g, h, i, j	
Max. equivalent length between branches		50 m	L2, L3, L4, L5, L6, L7	
Difference in height	Height between indoor and outdoor units H1	Upper outdoor unit	70 m ^(*4) ^(*7)	-
		Lower outdoor unit	40 m ^(*5)	-
	Height between indoor units H2		40 m	-
Height between outdoor units H3		5 m	-	

(*1) : (D) is outdoor unit furthest from the 1st branch and (j) is the indoor unit furthest from the 1st branch.
 (*2) : If the height difference (H1) between indoor and outdoor unit exceeds 3 m, set 65 m or less.
 (*3) : If the max. combined outdoor unit capacity is 54HP or more, then max. equivalent length is 70 m or less (real length is 50 m or less).
 (*4) : If the height difference (H2) between indoor units exceeds 3 m, set 50 m or less.
 (*5) : If the height difference (H2) between indoor units exceeds 3 m, set 30 m or less.
 (*6) : Total charging refrigerant is 140kg or less.
 (*7) : Extension up till 90m is possible with conditions below
 - Outdoor Temperature Cooling : 10 - 46 (DB)
 Heating : -5 - 15.5 (WB)
 - Equivalent length of farthest piping from 1st branching Li < 50m
 - Real length of main piping L1 < 100m
 - Height difference between indoor units H2 < 3M
 - Total capacity of combined indoor units : 90% - 105%
 - Single CDU, and up to 20HP
 - Minimum capacity of connectable indoor : unit 4HP or Larger



3-3. Selection of refrigerant piping

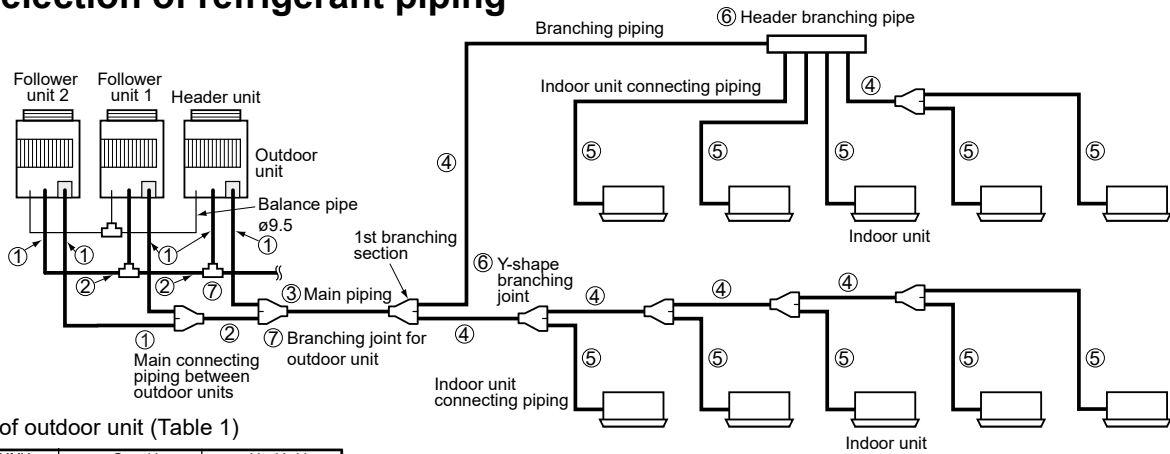

① Pipe size of outdoor unit (Table 1)

Model name MMY-	Gas side	Liquid side
MAP0806*, SAP0806*	Ø19.1	Ø12.7
MAP1006*, SAP1006*	Ø22.2	Ø12.7
MAP1206*, SAP1206*	Ø28.6	Ø12.7
MAP1406*	Ø28.6	Ø15.9
MAP1606*	Ø28.6	Ø15.9
MAP1806*	Ø28.6	Ø15.9
MAP2006*	Ø28.6	Ø15.9
MAP2206*	Ø28.6	Ø19.1

② Connecting pipe size between outdoor units (Table 2)

Total capacity code of outdoor unit at downstream side*1	Gas side	Liquid side	Balance pipe
16 to below 22	Ø28.6	Ø15.9	Ø9.5
22 to below 24	Ø28.6	Ø19.1	
24 to below 26	Ø34.9	Ø19.1	
26 to below 36	Ø34.9	Ø19.1	
36 or more	Ø41.3	Ø22.2	

③ Size of main pipe (Table 3)

Total capacity code of all outdoor units *1	Gas side	Liquid side	
		Standard pipe size	Refrigerant saving pipe size
8 to below 10	Ø19.1	Ø12.7	-
10 to below 12	Ø22.2	Ø12.7	-
12 to below 14	Ø28.6	Ø12.7	-
14 to below 22	Ø28.6	Ø15.9	Ø12.7
22 to below 24	Ø28.6	Ø19.1	Ø15.9
24 to below 36	Ø34.9	Ø19.1	Ø15.9
36 to below 46	Ø41.3	Ø22.2	Ø19.1
46 or more	Ø41.3	Ø22.2	-

Determine thickness of the main pipe according to capacity of the outdoor units.

④ Pipe size between branching sections (Table 4)*5

Total capacity code of indoor units at downstream side *1	Gas side	Liquid side
2.4 or less	Ø12.7	Ø9.5
2.4 to below 6.4	Ø15.9	Ø9.5
6.4 to below 12.2	Ø22.2	Ø12.7
12.2 to below 20.2	Ø28.6	Ø15.9
20.2 to below 22.4	Ø28.6	Ø19.1
22.4 to below 25.2	Ø34.9	Ø19.1
25.2 to below 35.2	Ø34.9	Ø19.1
32.2 or more	Ø41.3	Ø22.2

If the total capacity code value of indoor units exceeds that of the outdoor units, apply the capacity code of outdoor units.

⑤ Piping of indoor unit (Table 5)

Capacity rank	Gas side	Liquid side
005 type to 012 type	Ø9.5	Ø6.4
015 type to 018 type	Ø12.7	Ø6.4
024 type to 056 type	Ø15.9	Ø9.5
072 type to 096 type	Ø22.2	Ø12.7

⑥ Selection of branching section (Table 6)

Y-shape branching joint *2 *3 *8	Total capacity code of indoor unit *1		Model name
	Below 6.4		
Y-shape branching joint *2 *3 *8	Below 6.4		RBM-BY55E
	6.4 to below 20.2		RBM-BY105E
	20.2 to below 25.2		RBM-BY205E
Branching header *2 *3 *6 *8	25.2 or more		RBM-BY305E
	For 4 branching	Below 14.2	RBM-HY1043E
		14.2 to below 25.2	RBM-HY2043E
	For 8 branching	Below 14.2	RBM-HY1083E
14.2 to below 25.2		RBM-HY2083E	

⑦ Selection of branching joint for outdoor unit (Table 7)

	Total capacity code of outdoor unit	Joints			Model name
		Gas (Y-shape)	Liquid (T-shape)	Balance (T-shape)	
Branching joint for outdoor unit	Below 26				RBM-BT14E
	26 or more				RBM-BT24E

⑧ Minimum wall thickness for R410A application (Table 8)

Soft	Half hard or hard	OD (Inch)	OD (mm)	Minimum wall thickness (mm)
OK	OK	1/4"	6.35	0.80
OK	OK	3/8"	9.52	0.80
OK	OK	1/2"	12.70	0.80
OK	OK	5/8"	15.88	1.00
No Good*4	OK	3/4"	19.05	1.00
No Good*4	OK	7/8"	22.20	1.00
No Good*4	OK	1.1/8"	28.58	1.00
No Good*4	OK	1.3/8"	34.92	1.20
No Good*4	OK	1.5/8"	41.28	1.40

*1 Code is determined according to the capacity rank.

*2 When using a branching joint for the 1st branch, select according to capacity code of the outdoor unit.

*3 For 1 line after branching header indoor units with a maximum capacity code of 6.0 in total can be connected.

*4 If the pipe size is Ø19.0 or more, use a suitable material as detailed in the installation manual.

*5 If the piping size becomes over main piping size, select the size same as main piping.

*6 When the first branch is a header with the outdoor total capacity codes of 12 to 26, apply the model RBM-HY2043E(4-branch) or RBM-HY2083E(8-branch) regardless of the total capacity codes of the down-stream indoor units.

*7 The maximum equivalent length of main pipe should be 70m or shorter.

*8 When the sum of capacity code of indoor units exceeds the capacity code of outdoor units, select according to capacity code of the outdoor units.

*9 Refrigerant saving condition can be adopted under all the conditions below,
 - Real length of main piping (L1) : 50m or less
 - Height difference between outdoor and indoor units (H1) : 30m or less
 - Total capacity code of all outdoor units is 14HP to below 46HP.



3-4. Charging requirement with additional refrigerant

Calculating the amount of additional refrigerant required

Refrigerant in the system when shipped from the factory

Standard Model	MMY-MAP***6HT8P-E	8HP	10HP	12HP	14HP	16HP	18HP	20HP	22HP
Refrigerant amount charged in factory	Heat pump model	11.5 kg	11.5 kg	11.5 kg	11.5 kg	11.5 kg	11.5 kg	11.5 kg	11.5 kg

Stand alone model	MMY-SAP***6HT8P-E	8HP	10HP	12HP
Refrigerant amount charged in factory	Heat pump model	5.7 kg	5.7 kg	5.7 kg

When the system is charged with refrigerant at the factory, the amount of refrigerant needed for the pipes at the site is not included. Therefore, calculate the additional amount needed and add the required amount to the system.

(Calculation)

Additional refrigerant charge amount is calculated based on the size of liquid pipe at site and its real length.

Additional refrigerant charge amount at site = [1]+[2]+([3] x [4])

[1]. Compensation by system HP (Table 1)

[2]. Additional refrigerant charge amount indoor unit (Table 2)

[3]. Real length of liquid pipe x Additional refrigerant charge amount per liquid pipe (Table 3)

[4]. Correction factor for liquid pipe (Table 4)

Example: Additional charge amount R (kg) = [1] + [2] + ([3] x [4]) = 2.5 + 24 + (39.1 x 1.2) = 73.4

System HP : 60HP

Indoor unit (Standard Indoor units) : 60HP

Liquid pipe : 22.2 100m
19.1 10m
15.9 10m

[1]. Compensation by system HP = 2.5kg

[2]. Additional refrigerant charge amount Indoor unit = 0.4 kg x 60 = 24kg

[3]. Real length of liquid pipe x Additional refrigerant charge amount per liquid pipe = (0.350 x 100) + (0.250 x 10) + (0.160 x 10) = 35 + 2.5 + 1.6 = 39.1kg

[4]. Correction factor for liquid pipe = 1.2

Table 1

Standard model

System	Combination			Compensation by System HP
HP	HP			
8	8			-3.5
10	10			-3.5
12	12			-1.5
14	14			-1.0
16	16			-0.5
18	18			1.5
20	20			1.5
22	22			1.5
24	12	12		-3.0
26	14	12		-2.5
28	16	12		-2.0
30	16	14		-1.5
32	16	16		-1.0
34	18	16		1.0
36	20	16		1.0
38	22	16		1.0
40	20	20		3.0
42	22	20		3.0
44	22	22		3.0
46	16	16	14	-6.5
48	16	16	16	-6.5
50	18	16	16	-0.5
52	20	16	16	-0.5
54	22	16	16	-0.5
56	20	20	16	2.5
58	22	20	16	2.5
60	22	22	16	2.5

High efficiency model

System	Combination			Compensation by System HP
HP	HP			
20	10	10		-7.0
22	12	10		-7.0
36	12	12	12	-12.5
38	14	12	12	-10.5
40	14	14	12	-8.5
42	14	14	14	-4.5
44	16	14	14	-4.5
54	20	20	14	1.5

Stand alone model

System	Combination			Compensation by System HP
HP	HP			
8	8			0.0
10	10			0.4
12	12			0.8

Table 2

Standard model, High efficiency mode

Additional refrigerant charge amount Indoor unit	Standard Indoor unit	Hot Water Module	Fresh Air Intake Indoor Unit	Air to Air Heat exchanger with DX-coil
Additional refrigerant charge amount	kg/HP	0.4	0	0.2

Stand alone model

Indoor unit capacity rank	005	007	008	009	010	012	014	015	017	018	020	024	027	030	036	048	056	072	096
Capacity code (Equivalent to HP)	0.6	0.8	0.9	1	1.1	1.25	1.5	1.7	1.85	2	2.25	2.5	3	3.2	4	5	6	8	10
Additional refrigerant charge amount	kg				0.2				0.4				0.6				1.0		

Table 3

Pipe dia. at liquid side	mm	ø6.4	ø9.5	ø12.7	ø15.9	ø19.0	ø22.2
Additional refrigerant amount/1m	kg/m	0.025	0.055	0.105	0.16	0.25	0.35

Table 4

	Standard model, High efficiency mode	Stand alone model
Correction factor for liquid pipe	1.2	1.0



4-1. General

- Perform wiring of the power supply in conformance with the regulations of the local electric company.
- For cabling of the power supply of the indoor unit and the inter-unit cabling between indoor and outdoor units, refer to the Installation Manual of indoor unit.
- Never connect power supply to the terminal block (U1, U2, U3, U4, U5, U6) for control wiring. (The equipment breaks down.)
- Arrange the cables so that the electric wires do not come to contact with high-temperature part of the pipe; otherwise coating melts and an accident may be caused.
- After connecting cable to the terminal block, take off the trap and then fix the cable with cable clamp.
- Do not turn on power of the indoor unit until vacuuming of the refrigerant pipe will finish.

4-2. Summary of wiring design

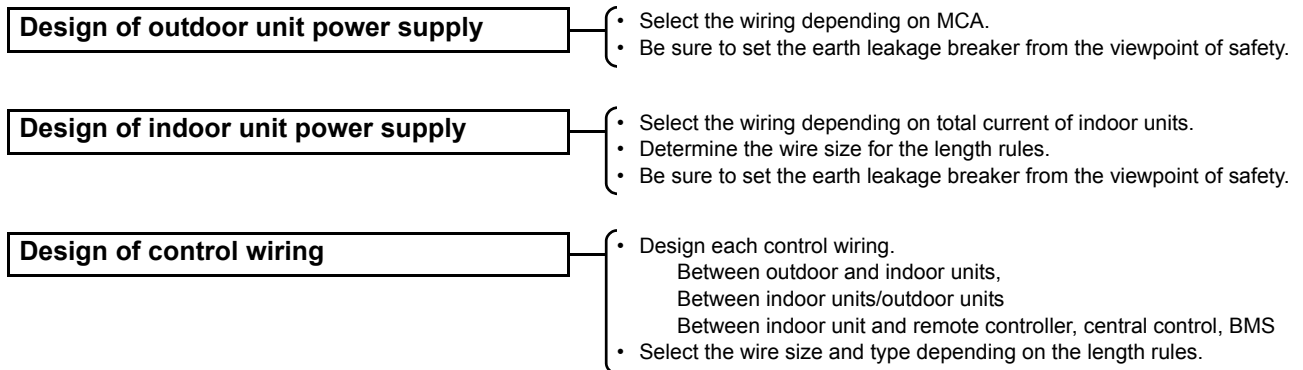

4-3. Electrical wiring design

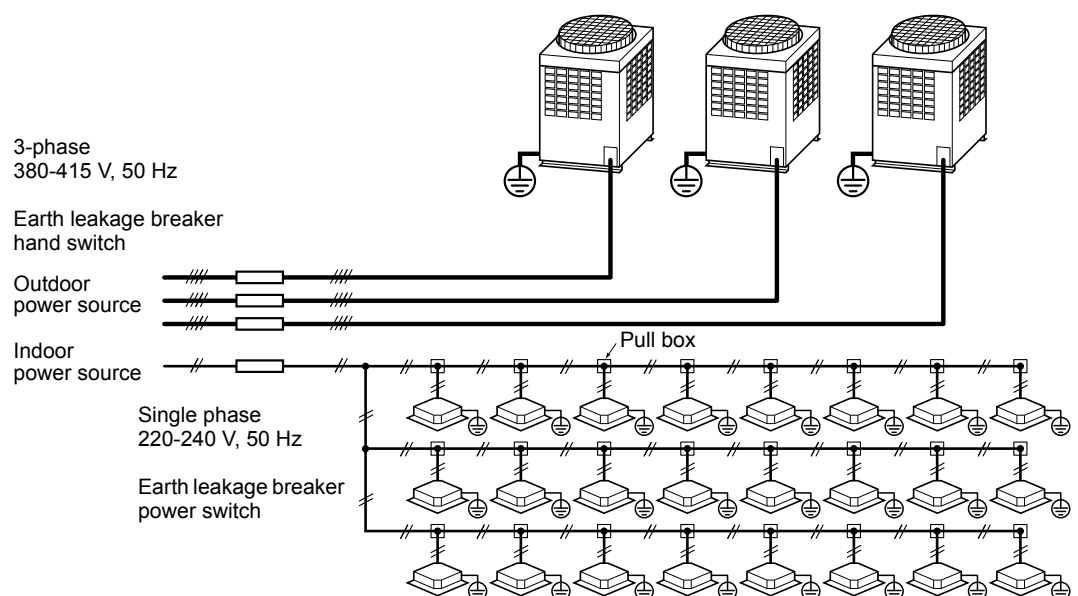

4-4. Outdoor unit power supply

4-4-1.

- Select the power supply cabling and fuse of each outdoor unit from the following specifications:
cable 4-core, in conformance with Design 60245 IEC 66
- Do not connect the outdoor units by crossing outside of them, but connect them via the terminal block (L1, L2, L3, N).

Outdoor power supply
3-phase
380-415 V, 50 Hz

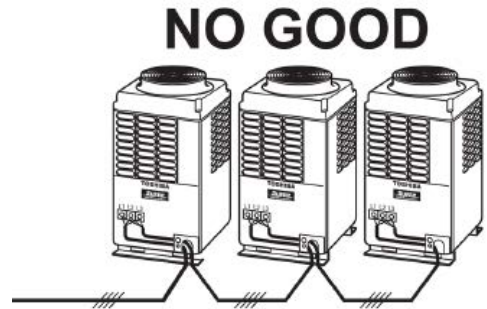



Outdoor unit data

Standard model

Type	HP	Heat Pump Model MMY-	Power Supply		Voltage Range		Compressor			Fan Motor (kW)	MCA (A)	MOCP (A)
			Phase and frequency	Nominal Voltage	Min. (V)	Max (V)	Unit No.1 (kW)	Unit No.2 (kW)	Unit No.3 (kW)			
Single unit	8	MMY-MAP0806HT8P-E	3N~ 50 Hz	380-400-415 V	342	456	2.1x2	-	-	1.0	20.5	25
	10	MMY-MAP1006HT8P-E	3N~ 50 Hz	380-400-415 V	342	456	3.1x2	-	-	1.0	21.5	25
	12	MMY-MAP1206HT8P-E	3N~ 50 Hz	380-400-415 V	342	456	3.9x2	-	-	1.0	26.1	32
	14	MMY-MAP1406HT8P-E	3N~ 50 Hz	380-400-415 V	342	456	4.8x2	-	-	1.0	31.0	40
	16	MMY-MAP1606HT8P-E	3N~ 50 Hz	380-400-415 V	342	456	5.8x2	-	-	1.0	35.8	40
	18	MMY-MAP1806HT8P-E	3N~ 50 Hz	380-400-415 V	342	456	6.5x2	-	-	2.0	40.6	50
	20	MMY-MAP2006HT8P-E	3N~ 50 Hz	380-400-415 V	342	456	7.6x2	-	-	2.0	44.9	63
Combination of outdoor unit	22	MMY-MAP2206HT8P-E	3N~ 50 Hz	380-400-415 V	342	456	9.0x2	-	-	2.0	49.3	63
	24	MMY-AP2416HT8P-E	3N~ 50 Hz	380-400-415 V	342	456	3.9x2	3.9x2	-	1.0+ 1.0	52.2	63
	26	MMY-AP2616HT8P-E	3N~ 50 Hz	380-400-415 V	342	456	4.8x2	3.9x2	-	1.0+ 1.0	57.1	63
	28	MMY-AP2816HT8P-E	3N~ 50 Hz	380-400-415 V	342	456	5.8x2	3.9x2	-	1.0+ 1.0	61.9	80
	30	MMY-AP3016HT8P-E	3N~ 50 Hz	380-400-415 V	342	456	5.8x2	4.8x2	-	1.0+ 1.0	66.8	80
	32	MMY-AP3216HT8P-E	3N~ 50 Hz	380-400-415 V	342	456	5.8x2	5.8x2	-	1.0+ 1.0	71.6	80
	34	MMY-AP3416HT8P-E	3N~ 50 Hz	380-400-415 V	342	456	6.5x2	5.8x2	-	2.0+ 1.0	76.4	100
	36	MMY-AP3616HT8P-E	3N~ 50 Hz	380-400-415 V	342	456	7.6x2	5.8x2	-	2.0+ 1.0	80.7	100
	38	MMY-AP3816HT8P-E	3N~ 50 Hz	380-400-415 V	342	456	9.0x2	5.8x2	-	2.0+ 1.0	85.1	100
	40	MMY-AP4016HT8P-E	3N~ 50 Hz	380-400-415 V	342	456	7.6x2	7.6x2	-	2.0+ 2.0	89.8	100
	42	MMY-AP4216HT8P-E	3N~ 50 Hz	380-400-415 V	342	456	9.0x2	7.6x2	-	2.0+ 2.0	94.2	125
	44	MMY-AP4416HT8P-E	3N~ 50 Hz	380-400-415 V	342	456	9.0x2	9.0x2	-	2.0+ 2.0	98.6	125
	46	MMY-AP4616HT8P-E	3N~ 50 Hz	380-400-415 V	342	456	5.8x2	5.8x2	4.8x2	1.0+ 1.0+ 1.0	102.6	125
	48	MMY-AP4816HT8P-E	3N~ 50 Hz	380-400-415 V	342	456	5.8x2	5.8x2	5.8x2	1.0+ 1.0+ 1.0	107.4	125
	50	MMY-AP5016HT8P-E	3N~ 50 Hz	380-400-415 V	342	456	6.5x2	5.8x2	5.8x2	2.0+ 1.0+ 1.0	112.2	125
	52	MMY-AP5216HT8P-E	3N~ 50 Hz	380-400-415 V	342	456	7.6x2	5.8x2	5.8x2	2.0+ 1.0+ 1.0	116.5	160
	54	MMY-AP5416HT8P-E	3N~ 50 Hz	380-400-415 V	342	456	9.0x2	5.8x2	5.8x2	2.0+ 1.0+ 1.0	120.9	160
	56	MMY-AP5616HT8P-E	3N~ 50 Hz	380-400-415 V	342	456	7.6x2	7.6x2	5.8x2	2.0+ 2.0+ 1.0	125.6	160
58	MMY-AP5816HT8P-E	3N~ 50 Hz	380-400-415 V	342	456	9.0x2	7.6x2	5.8x2	2.0+ 2.0+ 1.0	130.0	160	
60	MMY-AP6016HT8P-E	3N~ 50 Hz	380-400-415 V	342	456	9.0x2	9.0x2	5.8x2	2.0+ 2.0+ 1.0	134.4	160	

High efficiency / Heating capacity priority model

Type	HP	Heat Pump Model MMY-	Power Supply		Voltage Range		Compressor			Fan Motor (kW)	MCA (A)	MOCP (A)
			Phase and frequency	Nominal Voltage	Min. (V)	Max (V)	Unit No.1 (kW)	Unit No.2 (kW)	Unit No.3 (kW)			
Combination of outdoor unit	20	MMY-AP2026HT8P-E	3N~ 50 Hz	380-400-415 V	342	456	3.1x2	3.1x2	-	1.0+ 1.0	43.0	63
	22	MMY-AP2226HT8P-E	3N~ 50 Hz	380-400-415 V	342	456	3.9x2	3.1x2	-	1.0+ 1.0	47.6	63
	36	MMY-AP3626HT8P-E	3N~ 50 Hz	380-400-415 V	342	456	3.9x2	3.9x2	3.9x2	1.0+ 1.0+ 1.0	78.3	100
	38	MMY-AP3826HT8P-E	3N~ 50 Hz	380-400-415 V	342	456	4.8x2	3.9x2	3.9x2	1.0+ 1.0+ 1.0	83.2	100
	40	MMY-AP4026HT8P-E	3N~ 50 Hz	380-400-415 V	342	456	4.8x2	4.8x2	3.9x2	1.0+ 1.0+ 1.0	88.1	100
	42	MMY-AP4226HT8P-E	3N~ 50 Hz	380-400-415 V	342	456	4.8x2	4.8x2	4.8x2	1.0+ 1.0+ 1.0	93.0	125
	44	MMY-AP4426HT8P-E	3N~ 50 Hz	380-400-415 V	342	456	5.8x2	4.8x2	4.8x2	1.0+ 1.0+ 1.0	97.8	125
	54	MMY-AP5426HT8P-E	3N~ 50 Hz	380-400-415 V	342	456	7.6x2	7.6x2	4.8x2	2.0+ 2.0+ 1.0	120.8	160

Standard alone model

Type	HP	Heat Pump Model MMY-	Power Supply		Voltage Range		Compressor			Fan Motor (kW)	MCA (A)	MOCP (A)
			Phase and frequency	Nominal Voltage	Min (V)	Max (V)	Unit No.1 (kW)	Unit No.2 (kW)	Unit No.3 (kW)			
Combination of outdoor unit	8	MMY-SAP0806HT8P-E	3N~ 50 Hz	380-400-415 V	342	456	2.1x2	-	-	1.0	20.5	25
	10	MMY-SAP1006HT8P-E	3N~ 50 Hz	380-400-415 V	342	456	3.1x2	-	-	1.0	21.5	25
	12	MMY-SAP0806HT8P-E	3N~ 50 Hz	380-400-415 V	342	456	3.9x2	-	-	1.0	26.1	32

Note MCA : Minimum Circuit Amps

MOCP : Maximum Overcurrent Protection (Amps)



4-5. Indoor unit power supply

Electrical characteristics for 50 Hz outdoor units

Type	Model name	Capacity rank	Capacity Code	Cooling capacity(kW)	Heating capacity(kW)	Nominal Voltage (V-Ph-Hz)	Voltage Range		Fan Motor		Power Supply	
							Min	Max	kW	FLA	MCA	MOCP
4-way Air Discharge Cassette Type	MMU-AP0094HP1-E	009	1	2.8	3.2	230-150	198	264	0.014	0.63	0.79	15
	MMU-AP0124HP1-E	012	1.25	3.6	4.0	230-150	198	264	0.014	0.63	0.79	15
	MMU-AP0154HP1-E	015	1.7	4.5	5.0	230-150	198	264	0.014	0.80	1.00	15
	MMU-AP0184HP1-E	018	2	5.6	6.3	230-150	198	264	0.014	0.80	1.00	15
	MMU-AP0244HP1-E	024	2.5	7.1	8.0	230-150	198	264	0.020	0.87	1.09	15
	MMU-AP0274HP1-E	027	3.0	8.0	9.0	230-150	198	264	0.020	0.87	1.09	15
	MMU-AP0304HP1-E	030	3.2	9.0	10.0	230-150	198	264	0.020	0.87	1.09	15
	MMU-AP0364HP1-E	036	4.0	11.2	12.5	230-150	198	264	0.068	1.15	1.44	15
Compact 4-way Cassette (600 x 600) Type	MMU-AP0484HP1-E	048	5.0	14.0	16.0	230-150	198	264	0.072	1.15	1.44	15
	MMU-AP0564HP1-E	056	6	16.0	18.0	230-150	198	264	0.072	1.15	1.44	15
	MMU-AP0056MH1-E	005	0.6	1.7	1.9	230-150	198	264	0.060	0.32	0.40	15
	MMU-AP0074MH1-E	007	0.8	2.2	2.5	230-150	198	264	0.060	0.32	0.40	15
	MMU-AP0094MH1-E	009	1	2.8	3.2	230-150	198	264	0.060	0.35	0.44	15
	MMU-AP0124MH1-E	012	1.25	3.6	4.0	230-150	198	264	0.060	0.36	0.45	15
	MMU-AP0154MH1-E	015	1.7	4.5	5.0	230-150	198	264	0.060	0.48	0.60	15
	MMU-AP0184MH1-E	018	2	5.6	6.3	230-150	198	264	0.060	0.48	0.60	15
Compact 4-way Cassette (600 x 600) Type	MMU-AP0057MH-E	005	0.6	1.7	1.9	230-150	198	264	0.060	0.18	0.23	15
	MMU-AP0077MH-E	007	0.8	2.2	2.5	230-150	198	264	0.060	0.26	0.33	15
	MMU-AP0097MH-E	009	1	2.8	3.2	230-150	198	264	0.060	0.28	0.35	15
	MMU-AP0127MH-E	012	1.25	3.6	4.0	230-150	198	264	0.060	0.29	0.36	15
	MMU-AP0157MH-E	015	1.7	4.5	5.0	230-150	198	264	0.060	0.47	0.59	15
	MMU-AP0187MH-E	018	2	5.6	6.3	230-150	198	264	0.060	0.53	0.66	15
	MMU-AP0072WH1	007	0.8	2.2	2.5	230-150	198	264	0.020	0.32	0.40	15
	MMU-AP0092WH1	009	1	2.8	3.2	230-150	198	264	0.020	0.32	0.40	15
2-way Air Discharge Cassette Type	MMU-AP0122WH1	012	1.25	3.6	4.0	230-150	198	264	0.020	0.32	0.40	15
	MMU-AP0152WH1	015	1.7	4.5	5.0	230-150	198	264	0.020	0.32	0.40	15
	MMU-AP0182WH1	018	2	5.6	6.3	230-150	198	264	0.030	0.70	0.88	15
	MMU-AP0242WH1	024	2.5	7.1	8.0	230-150	198	264	0.040	0.81	1.01	15
	MMU-AP0272WH1	027	3	8.0	9.0	230-150	198	264	0.040	0.81	1.01	15
	MMU-AP0302WH1	030	3.2	9.0	10.0	230-150	198	264	0.050	0.81	1.01	15
	MMU-AP0362WH1	036	4.0	11.2	12.5	230-150	198	264	0.070	0.87	1.09	15
	MMU-AP0482WH1	048	5.0	14.0	16.0	230-150	198	264	0.070	0.87	1.09	15
1-way Air Discharge Cassette Type	MMU-AP0562WH1	056	6	16.0	18.0	230-150	198	264	0.070	0.87	1.09	15
	MMU-AP0074YH1-E	007	0.8	2.2	2.5	230-150	198	264	0.022	0.28	0.35	15
	MMU-AP0094YH1-E	009	1.0	2.8	3.2	230-150	198	264	0.022	0.28	0.35	15
	MMU-AP0124YH1-E	012	1.3	3.6	4.0	230-150	198	264	0.022	0.28	0.35	15
	MMU-AP0154SH1-E	015	1.7	4.5	5.0	230-150	198	264	0.030	0.40	0.49	15
	MMU-AP0184SH1-E	018	2.0	5.6	6.3	230-150	198	264	0.030	0.42	0.53	15
	MMU-AP0244SH1-E	024	2.5	7.1	8.0	230-150	198	264	0.030	0.71	0.88	15
	MMU-AP0302WH1	030	3.2	9.0	10.0	230-150	198	264	0.050	0.81	1.01	15
Concealed Duct Type	MMU-AP0362WH1	036	4.0	11.2	12.5	230-150	198	264	0.070	0.87	1.09	15
	MMU-AP0482WH1	048	5.0	14.0	16.0	230-150	198	264	0.070	0.87	1.09	15
	MMU-AP0562WH1	056	6	16.0	18.0	230-150	198	264	0.070	0.87	1.09	15
	MMD-AP0076BHP1-E	007	0.8	2.2	2.5	230-150	198	264	0.120	0.30	0.37	15
	MMD-AP0096BHP1-E	009	1.0	2.8	3.2	230-150	198	264	0.150	0.34	0.42	15
	MMD-AP0126BHP1-E	012	1.25	3.6	4.0	230-150	198	264	0.150	0.34	0.42	15
	MMD-AP0156BHP1-E	015	1.70	4.5	5.0	230-150	198	264	0.150	0.48	0.61	15
	MMD-AP0186BHP1-E	018	2.0	5.6	6.3	230-150	198	264	0.150	0.48	0.61	15
	MMD-AP0246BHP1-E	024	2.50	7.1	8.0	230-150	198	264	0.150	0.60	0.75	15
	MMD-AP0276BHP1-E	027	3.0	8.0	9.0	230-150	198	264	0.150	0.60	0.75	15
Slim Duct Type	MMD-AP0306BHP1-E	030	3.20	9.0	10.0	230-150	198	264	0.150	0.70	0.88	15
	MMD-AP0366BHP1-E	036	4.00	11.2	12.5	230-150	198	264	0.250	1.23	1.54	15
	MMD-AP0486BHP1-E	048	5.00	14.0	16.0	230-150	198	264	0.250	1.41	1.77	15
	MMD-AP0566BHP1-E	056	6.00	16.0	18.0	230-150	198	264	0.250	1.41	1.77	15
	MMD-AP0056SPH1-E	005	0.6	1.7	1.9	230-150	198	264	0.060	0.35	0.44	15
	MMD-AP0074SPH1-E	007	0.80	2.2	2.5	230-150	198	264	0.060	0.35	0.44	15
	MMD-AP0094SPH1-E	009	1.0	2.8	3.2	230-150	198	264	0.060	0.35	0.44	15
	MMD-AP0124SPH1-E	012	1.25	3.6	4.0	230-150	198	264	0.060	0.37	0.47	15
	MMD-AP0154SPH1-E	015	1.70	4.5	5.0	230-150	198	264	0.060	0.38	0.48	15
	MMD-AP0184SPH1-E	018	2.00	5.6	6.3	230-150	198	264	0.060	0.47	0.59	15
Concealed Duct High Static Pressure Type	MMD-AP0244SPH1-E	024	2.25	7.1	8.0	230-150	198	264	0.120	0.86	1.08	15
	MMD-AP0274SPH1-E	027	3.0	8.0	9.0	230-150	198	264	0.120	0.86	1.08	15
	MMD-AP0186HP1-E	018	2.0	5.6	6.3	230-150	198	264	0.250	1.02	1.28	15
	MMD-AP0246HP1-E	024	2.5	7.1	8.0	230-150	198	264	0.250	1.33	1.66	15
	MMD-AP0276HP1-E	027	3.0	8.0	9	230-150	198	264	0.250	1.33	1.66	15
	MMD-AP0366HP1-E	036	4.0	11.2	12.5	230-150	198	264	0.350	2.22	2.78	15
	MMD-AP0486HP1-E	048	5.0	14.0	16.0	230-150	198	264	0.350	2.40	2.99	15
	MMD-AP0566HP1-E	056	6.0	16.0	18.0	230-150	198	264	0.350	2.57	3.22	15
Under Ceiling Type	MMD-AP0726HP-E	072	8.0	22.4	25.0	230-150	198	264	0.37x3	6.04	7.55	15
	MMD-AP0966HP-E	096	10.0	28.0	31.5	230-150	198	264	0.37x3	6.35	7.94	15
	MMC-AP0158HP-E	015	1.7	4.5	5.0	230-150	198	264	0.094	0.41	0.52	15
	MMC-AP0188HP-E	018	2.0	5.6	6.3	230-150	198	264	0.094	0.42	0.53	15
	MMC-AP0248HP-E	024	2.5	7.1	8.0	230-150	198	264	0.094	0.75	0.93	15
	MMC-AP0278HP-E	027	3.0	8.0	9.0	230-150	198	264	0.094	0.75	0.93	15
	MMC-AP0368HP-E	036	4.0	11.2	12.5	230-150	198	264	0.139	0.89	1.11	15
	MMC-AP0488HP-E	048	5.0	14.0	16.0	230-150	198	264	0.139	0.89	1.11	15
MMC-AP0568HP-E	056	6.0	16.0	18.0	230-150	198	264	0.139	1.14	1.43	15	



Electrical characteristics for 50 Hz outdoor units

Type	Model name	Capacity rank	Capacity Code	Cooling capacity(kW)	Heating capacity(kW)	Nominal Voltage (V-Ph-Hz)	Voltage Range		Fan Motor		Power Supply	
							Min	Max	kW	FLA	MCA	MOCPP
High Wall Type 3 series	MMK-AP0073H1	007	0.8	2.2	2.5	230-1-50	198	264	0.030	0.20	0.22	15
	MMK-AP0093H1	009	1.0	2.8	3.2	230-1-50	198	264	0.030	0.22	0.24	15
	MMK-AP0123H1	012	1.25	3.6	4.0	230-1-50	198	264	0.030	0.22	0.24	15
	MMK-AP0153H1	015	1.7	4.5	5.0	230-1-50	198	264	0.030	0.37	0.40	15
	MMK-AP0183H1	018	2.0	5.6	6.3	230-1-50	198	264	0.030	0.37	0.40	15
	MMK-AP0243H1	024	2.5	7.1	8	230-1-50	198	264	0.030	0.43	0.47	15
High Wall Type 3 series (Without PMV)	MMK-AP0073HP1-E1	007	0.8	2.2	2.5	230-1-50	198	264	0.030	0.20	0.22	15
	MMK-AP0093HP1-E1	009	1.0	2.8	3.2	230-1-50	198	264	0.030	0.22	0.24	15
	MMK-AP0123HP1-E1	012	1.25	3.6	4.0	230-1-50	198	264	0.030	0.22	0.24	15
	MMK-AP0153HP1-E1	015	1.7	4.5	5.0	230-1-50	198	264	0.030	0.37	0.40	15
	MMK-AP0183HP1-E1	018	2.0	5.6	6.3	230-1-50	198	264	0.030	0.37	0.40	15
	MMK-AP0243HP1-E1	024	2.5	7.1	8	230-1-50	198	264	0.030	0.43	0.47	15
High Wall Type 7 series	MMK-AP0057HP-E	005	0.6	1.7	1.9	230-1-50	198	264	0.030	0.16	0.20	15
	MMK-AP0077HP-E	007	0.8	2.2	2.5	230-1-50	198	264	0.030	0.17	0.21	15
	MMK-AP0097HP-E	009	1	2.8	3.2	230-1-50	198	264	0.030	0.18	0.23	15
	MMK-AP0127HP-E	012	1.25	3.6	4	230-1-50	198	264	0.030	0.20	0.25	15
	MMK-AP0157HP-E	015	1.7	4.5	5.0	230-1-50	198	264	0.042	0.29	0.36	15
	MMK-AP0187HP-E	018	2.0	5.6	6.3	230-1-50	198	264	0.042	0.32	0.40	15
	MMK-AP0247HP-E	024	2.5	7.1	8.0	230-1-50	198	264	0.042	0.46	0.58	15
High Wall Type 7 series (Without PMV)	MMK-AP0057HP-E1	005	0.6	1.7	1.9	230-1-50	198	264	0.030	0.16	0.20	15
	MMK-AP0077HP-E1	007	0.8	2.2	2.5	230-1-50	198	264	0.030	0.17	0.21	15
	MMK-AP0097HP-E1	009	1	2.8	3.2	230-1-50	198	264	0.030	0.18	0.23	15
	MMK-AP0127HP-E1	012	1.25	3.6	4	230-1-50	198	264	0.030	0.20	0.25	15
	MMK-AP0157HP-E1	015	1.7	4.5	5.0	230-1-50	198	264	0.042	0.29	0.36	15
	MMK-AP0187HP-E1	018	2.0	5.6	6.3	230-1-50	198	264	0.042	0.32	0.40	15
	MMK-AP0247HP-E1	024	2.5	7.1	8.0	230-1-50	198	264	0.042	0.46	0.58	15
Floor Standing Concealed Type	MML-AP0074BH1-E	007	0.8	2.2	2.5	230-1-50	198	264	0.019	0.29	0.36	15
	MML-AP0094BH1-E	009	1	2.8	3.2	230-1-50	198	264	0.019	0.29	0.36	15
	MML-AP0124BH1-E	012	1.25	3.6	4	230-1-50	198	264	0.019	0.29	0.36	15
	MML-AP0154BH1-E	015	1.7	4.5	5	230-1-50	198	264	0.070	0.52	0.65	15
	MML-AP0184BH1-E	018	2	5.6	6.3	230-1-50	198	264	0.070	0.52	0.65	15
	MML-AP0244BH1-E	024	2.5	7.1	8	230-1-50	198	264	0.070	0.53	0.66	15
Floor Standing Cabinet Type	MML-AP0074H1-E	007	0.8	2.2	2.5	230-1-50	198	264	0.045	0.30	0.37	15
	MML-AP0094H1-E	009	1	2.8	3.2	230-1-50	198	264	0.045	0.30	0.37	15
	MML-AP0124H1-E	012	1.25	3.6	4	230-1-50	198	264	0.045	0.49	0.62	15
	MML-AP0154H1-E	015	1.7	4.5	5	230-1-50	198	264	0.045	0.49	0.62	15
	MML-AP0184H1-E	018	2	5.6	6.3	230-1-50	198	264	0.070	0.54	0.68	15
	MML-AP0244H1-E	024	2.5	7.1	8	230-1-50	198	264	0.070	0.54	0.68	15
Floor Standing Type	MMF-AP0156H1-E	015	1.7	4.5	5	230-1-50	198	264	0.062	0.44	0.56	15
	MMF-AP0186H1-E	018	2	5.6	6.3	230-1-50	198	264	0.062	0.44	0.56	15
	MMF-AP0246H1-E	024	2.5	7.1	8	230-1-50	198	264	0.062	0.69	0.86	15
	MMF-AP0276H1-E	027	3	8	9	230-1-50	198	264	0.062	0.69	0.86	15
	MMF-AP0366H1-E	036	4	11.2	12.5	230-1-50	198	264	0.109	1.04	1.29	15
	MMF-AP0486H1-E	048	5	14	16	230-1-50	198	264	0.109	1.27	1.58	15
	MMF-AP0566H1-E	056	6.0	16.0	18	230-1-50	198	264	0.109	1.27	1.58	15
Console Type	MML-AP0074NH1-E	007	0.8	2.2	2.5	230-1-50	198	264	0.041	0.21	0.26	15
	MML-AP0094NH1-E	009	1	2.8	3.2	230-1-50	198	264	0.041	0.21	0.26	15
	MML-AP0124NH1-E	012	1.3	4	4	230-1-50	198	264	0.041	0.25	0.31	15
	MML-AP0154NH1-E	015	1.7	5	5	230-1-50	198	264	0.041	0.32	0.40	15
	MML-AP0184NH1-E	018	2.0	5.6	6.3	230-1-50	198	264	0.041	0.46	0.58	15
Fresh Air Intake Indoor unit Type*2	MMD-AP0481HFE	048	5	14	8.9	230-1-50	198	264	0.160x2	0.45	0.56	15
	MMD-AP0721HFE	072	8	22.4	13.9	230-1-50	198	264	0.160x2	0.45	0.56	15
	MMD-AP0961HFE	096	10	28	17.4	230-1-50	198	264	0.160x2	0.52	0.65	15
Hot Water Module*2	MMW-AP0271LQ-E	027	3	-	9	230-1-50	198	264	-	-	0.90	15
	MMW-AP0561LQ-E	056	6	-	18.0	230-1-50	198	264	-	-	0.90	15
Air to Air Heat exchanger with DX-coil Type*2	MMD-VN502HEX1E	009	1.0	4.1(1.30)*1	5.53(2.33)*1	230-1-50	198	264	0.248	1.50	1.70	15
	MMD-VN802HEX1E	015	1.7	6.56(2.06)*1	8.61(3.61)*1	230-1-50	198	264	0.254	2.60	3.00	15
	MMD-VN1002HEX1E	018	2.0	8.25(2.32)*1	10.92(4.32)*1	230-1-50	198	264	0.568	2.90	3.50	15
Air to Air Heat exchanger with DX-coil Humidifier Type*2	MMD-VNK502HEX1E	009	1	4.1(1.30)*1	5.53(2.33)*1	230-1-50	198	264	0.248	1.50	1.70	15
	MMD-VNK802HEX1E	015	1.7	6.56(2.06)*1	8.61(3.61)*1	230-1-50	198	264	0.254	2.60	2.90	15
	MMD-VNK1002HEX1E	018	2	8.25(2.32)*1	10.92(4.32)*1	230-1-50	198	264	0.568	2.90	3.40	15

*1 : The figures in () indicate the heat reclaimed from the heat recovery ventilator.

*2 : This indoor unit can't be connected to the Stand alone type(MMY-SAP***6HT8P-E).



• **Wiring size**

Must be independent from the outdoor unit power supply

Model \ Item	Power supply wiring			
	Wire size			
All models of indoor units	2.0 mm ² (AWG#14)	Max. 20 m	3.5 mm ² (AWG#12)	Max. 50 m

NOTE:

The above connecting lengths stated in the table, indicate the length from the isolator to the outdoor unit. When the power supply of the indoor units are connected in parallel, it is assumed that no more than a 2 % voltage drop will occur. If the connecting length is to exceed the stated lengths, select a suitable wire in accordance with the local wiring standards.

4-6.Design of control wiring

• Summary of control wiring

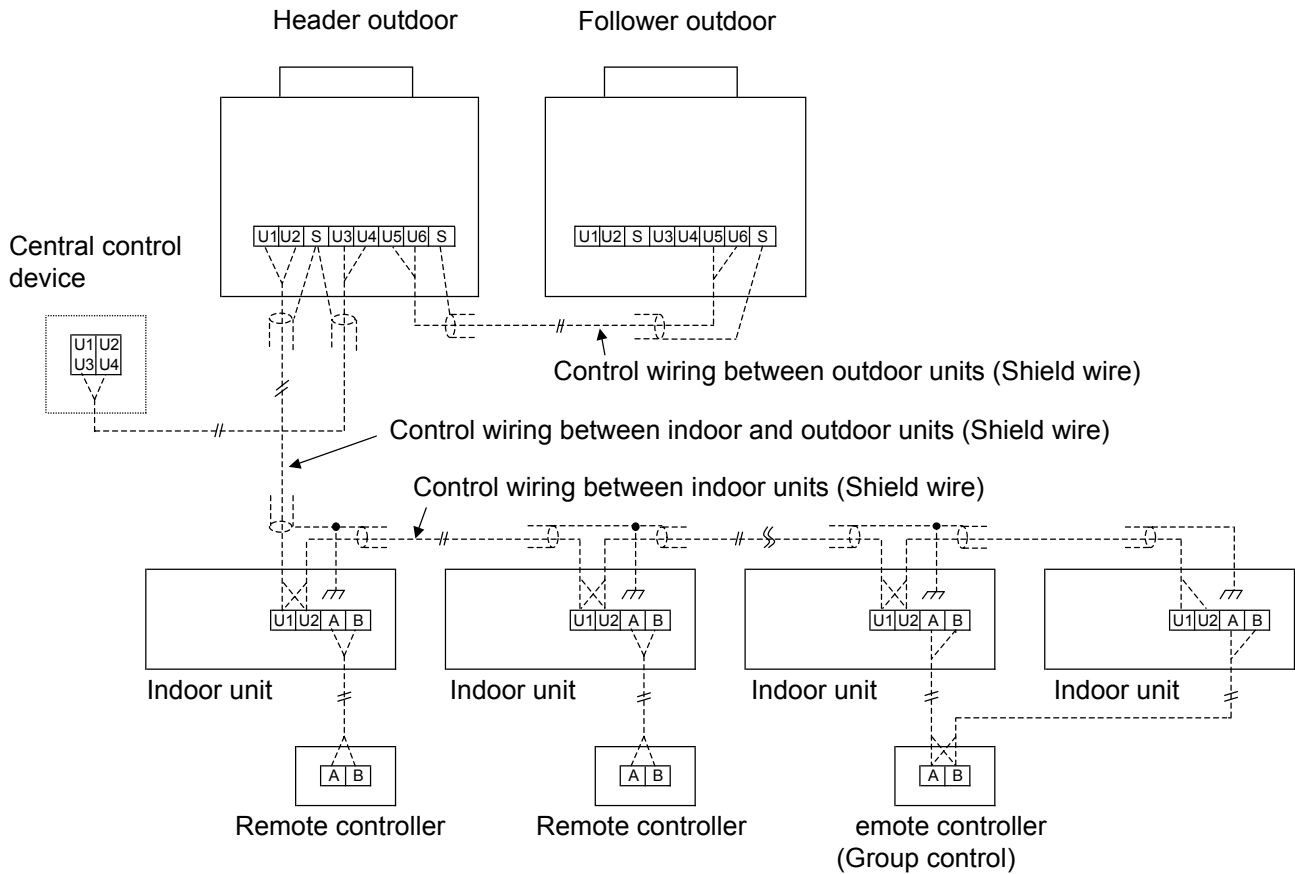

- Communication wiring and central control wiring use 2-core non-polarity wires. Use 2-core shield wires to prevent noise trouble. In this case, both ends of the communication wire must be grounded.
- Use 2-core non-polarity wire for remote controller. (A, B terminals)
Use 2-core non-polarity wire for wiring of group control. (A, B terminals)

• Restriction of control wiring

Be sure to keep the rule of below tables about size and length of control wiring.

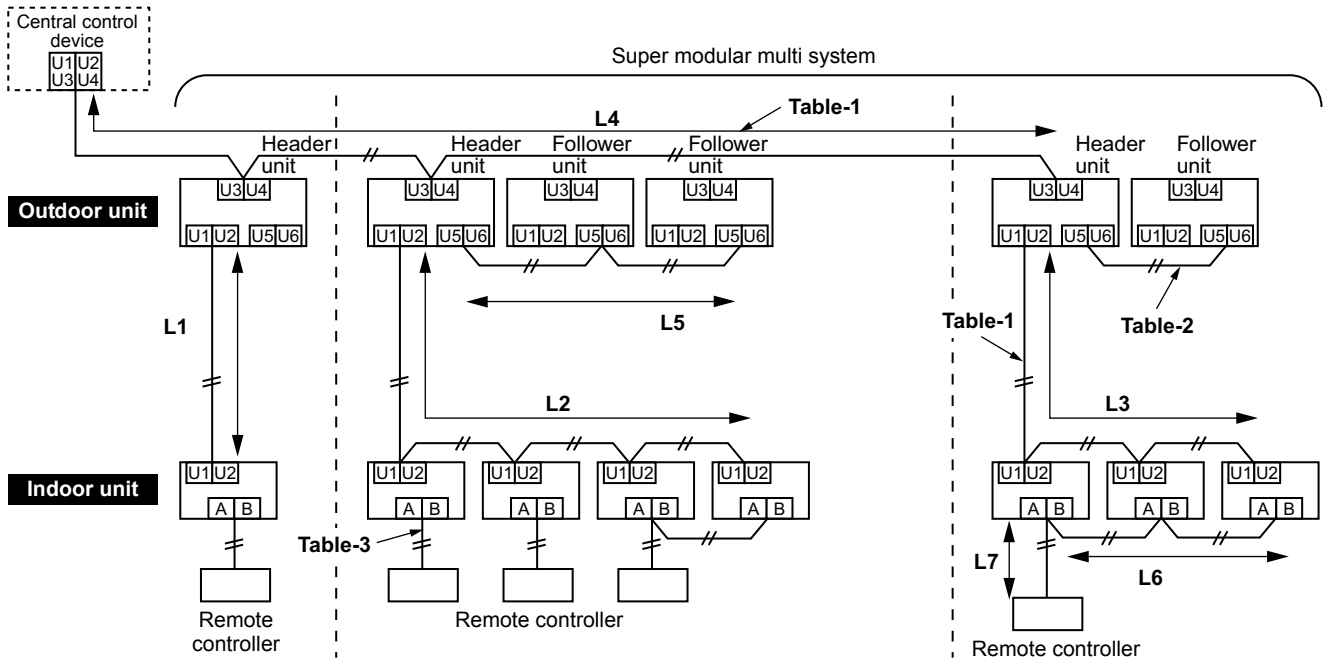

Table-1 Control wiring between indoor and outdoor units (L1, L2, L3), Central control wiring (L4)

Wiring	2-core, non-polarity
Type	Shield wire
Size/Length	1.25 mm ² : Up to 1000 m/2.0 mm ² : Up to 2000 m (*1)

Note (*1): Total length of control wiring length for all refrigerant circuits (L1 + L2 + L3 + L4)

Table-2 Control wiring between outdoor units (L5)

Wiring	2-core, non-polarity
Type	Shield wire
Size/Length	1.25 mm ² to 2.0 mm ² /Up to 100 m (L5)

Table-3 Remote controller wiring (L6, L7)

Wire	2-core
Size	0.5 mm ² to 2.0 mm ²
Length	<ul style="list-style-type: none"> • Up to 500 m (L6 + L7) • Up to 400 m in case of wireless remote controller in group control. • Up to 200 m total length of control wiring between indoor units (L6)

• Group Operation through a Remote Controller

Group operation of multiple indoor units (8 units) through a single remote controller switch

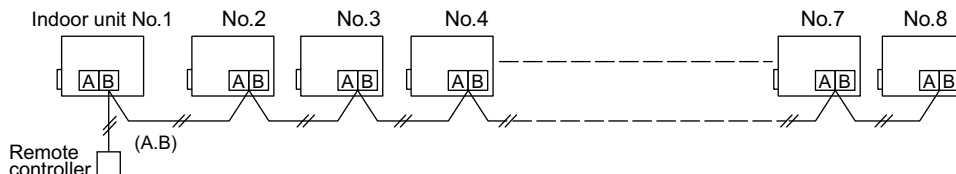



5-1. Specifications

Standard model

Model name		Heat pump		MMY-MAP0806HT8P-E	MMY-MAP1006HT8P-E	MMY-MAP1206HT8P-E	MMY-MAP1406HT8P-E
Outdoor unit type				Inverter unit	Inverter unit	Inverter unit	Inverter unit
Cooling capacity (*1)		kW		22.4	28.0	33.5	40.0
Heating capacity (*1)		kW		25.0	31.5	37.5	45.0
Capacity range		HP		8	10	12	14
Power supply				3N~ 50Hz 400V(380-415V)	3N~ 50Hz 400V(380-415V)	3N~ 50Hz 400V(380-415V)	3N~ 50Hz 400V(380-415V)
Voltage range (*2)		Minimum	V	342	342	342	342
		Maximum	V	456	456	456	456
Electrical characteristic (*1)	Cooling	Running current	A	8.79	12.1	15.5	19.5
		Power input	kW	5.54	7.69	10.0	12.3
		EER	kW/kW	4.04	3.64	3.35	3.25
		Running current	A	8.77	11.6	15.0	17.8
	Heating	Power input	kW	5.53	7.41	9.65	11.2
		COP	kW/kW	4.52	4.25	3.89	4.02
		Starting current	A	Soft Start	Soft Start	Soft Start	Soft Start
	Dimension		Height	mm	1830	1830	1830
Width			mm	990	990	990	1210
Depth			mm	780	780	780	780
Weight	Heat pump		kg	242	242	242	300
Color				Silky shade (Munsell 1Y8.5/0.5)	Silky shade (Munsell 1Y8.5/0.5)	Silky shade (Munsell 1Y8.5/0.5)	Silky shade (Munsell 1Y8.5/0.5)
Compressor		Type		Hermetic twin rotary compressor	Hermetic twin rotary compressor	Hermetic twin rotary compressor	Hermetic twin rotary compressor
		Motor output	kW	2.1x2	3.1x2	3.9x2	4.8x2
Fan unit		Type		Propeller fan	Propeller fan	Propeller fan	Propeller fan
		Motor output	W	1.0	1.0	1.0	1.0
		Air volume	m3/h	9700	9700	12200	12200
Max. external static pressure		Pa		60	60	50	50
Heat exchanger				Finned tube	Finned tube	Finned tube	Finned tube
Refrigerant		Name		R410A	R410A	R410A	R410A
		Charge	Heat pump	kg	11.5	11.5	11.5
High-pressure switch		Pa		OFF:3.2 ON:4.15	OFF:3.2 ON:4.15	OFF:3.2 ON:4.15	OFF:3.2 ON:4.15
Protective devices				(*3)	(*3)	(*3)	(*3)
Power supply wiring		MCA (*4)	A	20.5	21.5	26.1	31.0
		MOCP (*5)	A	25.0	25.0	32.0	40.0
Piping connections		Gas	Type	Brazing	Brazing	Brazing	Brazing
			Diameter	mm	19.1	22.2	28.6
		Liquid	Type	Flare	Flare	Flare	Flare
			Diameter	mm	12.7	12.7	12.7
		Balance	Type	Flare	Flare	Flare	Flare
			Diameter	mm	9.5	9.5	9.5
Max. number of connected indoor units				18	22	27	31
Sound pressure level		Cooling	dB(A)	55.0	57.0	59.0	60.0
		Heating	dB(A)	56.0	58.0	61.0	62.0
Sound power level		Cooling	dB(A)	74.0	74.0	80.0	80.0
		Heating	dB(A)	74.0	74.0	82.0	82.0
Operation temperature range		Cooling (*7)	CDB	-10.0 to 46.0	-10.0 to 46.0	-10.0 to 46.0	-10.0 to 46.0
		Heating(*6)	CWB	-25.0 to 15.5	-25.0 to 15.5	-25.0 to 15.5	-25.0 to 15.5

Note

(*1) Rated conditions

Cooling : Indoor 27 degC Dry Bulb / 19 degC Wet Bulb , Outdoor 35 degC Dry Bulb.

Heating : Indoor 20 degC Dry Bulb , Outdoor 7 degC Dry Bulb / 6 degC Wet Bulb.

Based on equivalent piping length of 7.5m and piping height difference of 0m.

(*2) Voltage range : Units are suitable for use on electrical systems where voltage supplied to unit terminal is not below or above listed range limits.

(*3) Discharge temp. sensor / Suction temp. sensor / High-pressure sensor / Low-pressure sensor / Compressor case thermostat / PC board fuse

(*4) Select wire size base on the larger value of MCA.

MCA : Minimum Circuit Amps

(*5) MOCP : Maximum Overcurrent Protection(Amps)

(*6) Low ambient heating (-20degC or less) for extended periods of time is not allowed

(*7) Low ambient cooling (-5 deg C or less) is limited to application.

(*8) This pipe size can be used in refrigerant saving condition. Refrigerant saving condition can be adopted under all the conditions below,

- Real length of main piping (L1) : 50m or less
- Height difference between outdoor and indoor units (H1) : 30m or less
- Total capacity codes of all outdoor units is 14HP to below 46HP.



Model name		Heat pump		MMY-MAP1606HT8P-E	MMY-MAP1806HT8P-E	MMY-MAP2006HT8P-E	MMY-MAP2206HT8P-E	
Outdoor unit type				Inverter unit		Inverter unit		
Cooling capacity (*1)		kW	45.0	50.4	56.0	61.5	61.5	
Heating capacity (*1)		kW	50.0	56.0	63.0	64.0	64.0	
Capacity range		HP	16	18	20	22	22	
Power supply				3N~ 50Hz 400V(380-415V)	3N~ 50Hz 400V(380-415V)	3N~ 50Hz 400V(380-415V)	3N~ 50Hz 400V(380-415V)	
Voltage range (*2)		Minimum	V	342	342	342	342	
		Maximum	V	456	456	456	456	
Electrical characteristic (*1)		Cooling	Running current	A	22.40	22.90	26.80	35.60
			Power input	kW	14.30	14.60	17.30	23.20
			EER	kW/kW	3.15	3.45	3.24	2.65
		Heating	Running current	A	20.20	22.10	26.10	29.20
			Power input	kW	12.90	14.10	17.00	18.80
			COP	kW/kW	3.88	3.97	3.71	3.40
Starting current		A	Soft Start	Soft Start	Soft Start	Soft Start		
Dimension		Height	mm	1830	1830	1830	1830	
		Width	mm	1210	1600	1600	1600	
		Depth	mm	780	780	780	780	
Weight		Heat pump	kg	300	371	371	371	
Colour				Silky shade (Munsell 1Y8.5/0.5)	Silky shade (Munsell 1Y8.5/0.5)	Silky shade (Munsell 1Y8.5/0.5)	Silky shade (Munsell 1Y8.5/0.5)	
Compressor		Type		Hermetic twin rotary compressor	Hermetic twin rotary compressor	Hermetic twin rotary compressor	Hermetic twin rotary compressor	
		Motor output	kW	5.8x2	6.5x2	7.6x2	9.0x2	
Fan unit		Type		Propeller fan	Propeller fan	Propeller fan	Propeller fan	
		Motor output	kW	1.0	2.0	2.0	2.0	
		Air volume	m3/h	12600	17300	17900	18500	
Max. external static pressure		Pa	40	50	40	40		
Heat exchanger				Finned tube		Finned tube		
Refrigerant		Name		R410A	R410A	R410A	R410A	
		Charge	Heat pump	kg	11.5	11.5	11.5	11.5
High-pressure switch		Pa	OFF:3.2 ON:4.15	OFF:3.2 ON:4.15	OFF:3.2 ON:4.15	OFF:3.2 ON:4.15		
Protective devices				(*3)	(*3)	(*3)	(*3)	
Power supply wiring		MCA (*4)	A	35.8	40.6	44.9	49.3	
		MOCP (*5)	A	40.0	50.0	63.0	63.0	
Piping connections		Gas	Type		Brazing	Brazing	Brazing	
			Diameter	mm	28.6	28.6	28.6	28.6
		Liquid	Type		Flare	Flare	Flare	Flare
			Diameter	mm	15.9	15.9	15.9	19.1
		Balance	Type		Flare	Flare	Flare	Flare
			Diameter	mm	9.5	9.5	9.5	9.5
Max. number of connected indoor units				36	40	45	49	
Sound pressure level		Cooling	dB(A)	62.0	60.0	61.0	61.0	
		Heating	dB(A)	64.0	61.0	62.0	62.0	
Sound power level		Cooling	dB(A)	81.0	81.0	82.0	83.0	
		Heating	dB(A)	83.0	83.0	84.0	84.0	
Operation temperature range		Cooling(*7)	CDB	-10.0 to 46.0	-10.0 to 46.0	-10.0 to 46.0	-10.0 to 46.0	
		Heating(*6)	CWB	-25.0 to 15.5	-25.0 to 15.5	-25.0 to 15.5	-25.0 to 15.5	

Note

(*1) Rated conditions

Cooling : Indoor 27 degC Dry Bulb / 19 degC Wet Bulb , Outdoor 35 degC Dry Bulb.

Heating : Indoor 20 degC Dry Bulb, Outdoor 7 degC Dry Bulb / 6 degC WetBulb.

Based on equivalent piping length of 7.5m and piping height difference of 0m.

(*2) Voltage range : Units are suitable for use on electrical systems where voltage supplied to unit terminal is not below or above listed range limits.

(*3) Discharge temp. sensor / Suction temp. sensor / High-pressure sensor / Low-pressure sensor / Compressor case thermostat / PC board fuse

(*4) Select wire size base on the larger value of MCA.

MCA : Minimum Circuit Amps

(*5) MOCP : Maximum Overcurrent Protection(Amps)

(*6) Low ambient heating (-20degC or less) for extended periods of time is not allowed

(*7)

1. Not suitable for applications, which require precise room temperature control, due to increased risk of indoor ON/OFF control and and potential low air off temperatures.
2. For areas that do demand a precise room temperature control, we would recommend the installation of a secondary system, which has been designed solely for the purpose of low ambient cooling.
3. Single outdoor unit only.
4. No height difference between units.
5. The cooling performance may decline considerably when total operating capacity of indoor units is less than 4HP while ambient temperature is below -5 C.



Model	Name	Heat pump		MMY-AP2416HT8P-E	MMY-AP2616HT8P-E	MMY-AP2816HT8P-E	MMY-AP3016HT8P-E			
	Combination	Heat pump		MMY-MAP1206HT8P-E	MMY-MAP1406HT8P-E	MMY-MAP1606HT8P-E	MMY-MAP1606HT8P-E			
				MMY-MAP1206HT8P-E	MMY-MAP1206HT8P-E	MMY-MAP1206HT8P-E	MMY-MAP1406HT8P-E			
Outdoor unit type				Inverter unit	Inverter unit	Inverter unit	Inverter unit			
Cooling capacity (*1)			kW	67.0	73.5	78.5	85.0			
Heating capacity (*1)			kW	75.0	82.5	87.5	95.0			
Capacity range			HP	24	26	28	30			
Power supply				3N~ 50Hz 400V(380-415V)	3N~ 50Hz 400V(380-415V)	3N~ 50Hz 400V(380-415V)	3N~ 50Hz 400V(380-415V)			
Voltage range (*2)			Minimum	V	342	342	342			
			Maximum	V	456	456	456			
Electrical characteristic (*1)			Cooling		Running current	A	31.0			
			Power input		kW	20.0	22.3	24.3	26.6	
			EER		kW/kW	3.35	3.3	3.23	3.2	
			Heating		Running current	A	30.0	32.8	35.2	38.0
					Power input	kW	19.3	20.9	22.6	24.1
			COP		kW/kW	3.89	3.96	3.88	3.94	
			Starting current		A	Soft Start	Soft Start	Soft Start	Soft Start	
			Weight	Heat pump		kg	242 + 242	300 + 242	300 + 242	300 + 300
Colour				Silky shade (Munsell 1Y8.5/0.5)	Silky shade (Munsell 1Y8.5/0.5)	Silky shade (Munsell 1Y8.5/0.5)	Silky shade (Munsell 1Y8.5/0.5)			
Compressor	Type			Hermetic twin rotary compressor	Hermetic twin rotary compressor	Hermetic twin rotary compressor	Hermetic twin rotary compressor			
	Motor output		kW	3.9x2 + 3.9x2	4.8x2 + 3.9x2	5.8x2 + 3.9x2	5.8x2 + 4.8x2			
Fan unit	Fan			Propeller fan	Propeller fan	Propeller fan	Propeller fan			
	Motor output		kW	1.0 + 1.0	1.0 + 1.0	1.0 + 1.0	1.0 + 1.0			
	Air volume		m ³ /h	12200 + 12200	12200 + 12200	12600 + 12200	12600 + 12200			
Max. external static pressure			Pa	50	50	40	40			
Heat exchanger				Finned tube	Finned tube	Finned tube	Finned tube			
Refrigerant	Name			R410A	R410A	R410A	R410A			
	Charge	Heat pump		kg	11.5 + 11.5	11.5 + 11.5	11.5 + 11.5	11.5 + 11.5		
High-pressure switch			Pa	OFF:3.2 ON:4.15	OFF:3.2 ON:4.15	OFF:3.2 ON:4.15	OFF:3.2 ON:4.15			
Protective devices				(*3)	(*3)	(*3)	(*3)			
Power supply wiring			MCA (*4)	A	52.2	57.1	61.9			
			MOCP (*5)	A	63.0	63.0	80.0	80.0		
Piping connections	Gas	Type		Brazing	Brazing	Brazing	Brazing			
		Diameter	mm	34.9	34.9	34.9	34.9			
	Liquid	Type		Flare	Flare	Flare	Flare			
		Diameter	mm	19.1 or 15.9 (*7)	19.1 or 15.9 (*7)	19.1 or 15.9 (*7)	19.1 or 15.9 (*7)			
	Balance	Type		Flare	Flare	Flare	Flare			
		Diameter	mm	9.5	9.5	9.5	9.5			
Max. number of connected indoor units				54	58	63	64			
Sound pressure level			Cooling	dB(A)	62.0	62.5	64.0			
			Heating	dB(A)	64.0	64.5	66.0	66.5		
Sound power level			Cooling	dB(A)	83.0	83.0	83.5			
			Heating	dB(A)	85.0	85.0	85.5	85.5		
Operation temperature range			Cooling	CDB	-5.0 to 46.0	-5.0 to 46.0	-5.0 to 46.0			
			Heating(*6)	CWB	-25.0 to 15.5	-25.0 to 15.5	-25.0 to 15.5	-25.0 to 15.5		

Note

(*1) Rated conditions

Cooling : Indoor 27 degC Dry Bulb /19 degC Wet Bulb , Outdoor 35 degC Dry Bulb.

Heating : Indoor 20 degC Dry Bulb, Outdoor 7 degC Dry Bulb / 6 degC Wet Bulb.

Based on equivalent piping length of 7.5m and piping height difference of 0m.

(*2) Voltage range : Units are suitable for use on electrical systems where voltage supplied to unit terminal is not below or above listed range limits.

(*3) Discharge temp. sensor / Suction temp. sensor / High-pressure sensor / Low-pressure sensor / Compressor case thermostat / PC board fuse

(*4) Select wire size base on the larger value of MCA.

MCA : Minimum Circuit Amps

(*5) MOCP : Maximum Overcurrent Protection(Amps)

(*6) Low ambient heating (-20degC or less) for extended periods of time is not allowed

(*7) Low ambient cooling (-5 deg C or less) is limited to application.

(*8) This pipe size can be used in refrigerant saving condition. Refrigerant saving condition can be adopted under all the conditions below.

- Real length of main piping (L1) : 50m or less
- Height difference between outdoor and indoor units (H1) : 30m or less
- Total capacity codes of all outdoor units is 14HP to below 46HP.



Model	Name		Heat pump	MMY-AP3216HT8P-E	MMY-AP3416HT8P-E	MMY-AP3616HT8P-E	MMY-AP3816HT8P-E
	Combination		Heat pump	MMY-MAP1606HT8P-E	MMY-MAP1806HT8P-E	MMY-MAP2006HT8P-E	MMY-MAP2206HT8P-E
				MMY-MAP1606HT8P-E	MMY-MAP1606HT8P-E	MMY-MAP1606HT8P-E	MMY-MAP1606HT8P-E
Outdoor unit type				Inverter unit	Inverter unit	Inverter unit	Inverter unit
Cooling capacity (*1)			kW	90.0	95.4	101.0	106.5
Heating capacity (*1)			kW	100.0	106.0	113.0	114.0
Capacity range			HP	32	34	36	38
Power supply				3N~ 50Hz 400V(380-415V)	3N~ 50Hz 400V(380-415V)	3N~ 50Hz 400V(380-415V)	3N~ 50Hz 400V(380-415V)
Voltage range (*2)			Minimum	V	342	342	342
			Maximum	V	456	456	456
Electrical characteristic (*1)	Cooling	Running current	A	44.80	45.30	49.20	58.00
		Power input	kW	28.60	28.90	31.60	37.50
		EER	kW/kW	3.15	3.30	3.20	2.84
	Heating	Running current	A	40.40	42.30	46.30	49.40
		Power input	kW	25.80	27.00	29.90	31.70
		COP	kW/kW	3.88	3.93	3.78	3.60
	Starting current		A	Soft Start	Soft Start	Soft Start	Soft Start
Weight	Heat pump		kg	300 + 300	371 + 300	371 + 300	371 + 300
Colour				Silky shade (Munsell 1Y8.5/0.5)	Silky shade (Munsell 1Y8.5/0.5)	Silky shade (Munsell 1Y8.5/0.5)	Silky shade (Munsell 1Y8.5/0.5)
Compressor	Type			Hermetic twin rotary compressor	Hermetic twin rotary compressor	Hermetic twin rotary compressor	Hermetic twin rotary compressor
	Motor output		kW	5.8x2 + 5.8x2	6.5x2 + 5.8x2	7.6x2 + 5.8x2	9.0x2 + 5.8x2
Fan unit	Fan			Propeller fan	Propeller fan	Propeller fan	Propeller fan
	Motor output		kW	1.0 + 1.0	2.0 + 1.0	2.0 + 1.0	2.0 + 1.0
	Air volume		m3/h	12600 + 12600	17300 + 12600	17900 + 12600	18500 + 12600
Max. external static pressure			Pa	40	40	40	40
Heat exchanger				Finned tube	Finned tube	Finned tube	Finned tube
Refrigerant	Name			R410A	R410A	R410A	R410A
	Charge	Heat pump	kg	11.5 + 11.5	11.5 + 11.5	11.5 + 11.5	11.5 + 11.5
High-pressure switch			Pa	OFF:3.2 ON:4.15	OFF:3.2 ON:4.15	OFF:3.2 ON:4.15	OFF:3.2 ON:4.15
Protective devices				(*3)	(*3)	(*3)	(*3)
Power supply wiring			MCA (*4)	A	71.6	76.4	80.7
			MOCP (*5)	A	80.0	100.0	100.0
Piping connections	Gas	Type		Brazing	Brazing	Brazing	Brazing
		Diameter	mm	34.9	34.9	41.3	41.3
	Liquid	Type		Flare	Flare	Flare	Flare
		Diameter	mm	19.1	19.1	22.2	22.2
	Balance	Type		Flare	Flare	Flare	Flare
		Diameter	mm	9.5	9.5	9.5	9.5
Max. number of connected indoor units				64	64	64	64
Sound pressure level			Cooling	dB(A)	65.0	64.5	64.5
			Heating	dB(A)	67.0	66.0	66.5
Sound power level			Cooling	dB(A)	84.0	84.0	84.5
			Heating	dB(A)	86.0	86.0	86.5
Operation temperature range			Cooling	CDB	-5.0 to 46.0	-5.0 to 46.0	-5.0 to 46.0
			Heating(*6)	CWB	-25.0 to 15.5	-25.0 to 15.5	-25.0 to 15.5

Note

(*1) Rated conditions

Cooling : Indoor 27 degC Dry Bulb /19 degC Wet Bulb , Outdoor 35 degC Dry Bulb.

Heating : Indoor 20 degC Dry Bulb , Outdoor 7 degC Dry Bulb / 6 degC WetBulb.

Based on equivalent piping length of 7.5m and piping height difference of 0m.

(*2) Voltage range : Units are suitable for use on electrical systems where voltage supplied to unit terminal is not below or above listed range limits.

(*3) Discharge temp. sensor / Suction temp. sensor / High-pressure sensor / Low-pressure sensor / Compressor case thermostat / PC board fuse

(*4) Select wire size base on the larger value of MCA.

MCA : Minimum Circuit Amps

(*5) MOCP : Maximum Overcurrent Protection(Amps)

(*6) Low ambient heating (-20degC or less) for extended periods of time is not allowed



Model	Name	Heat pump		MMY-AP4016HT8P-E	MMY-AP4216HT8P-E	MMY-AP4416HT8P-E
	Combination	Heat pump		MMY-MAP2006HT8P-E	MMY-MAP2206HT8P-E	MMY-MAP2206HT8P-E
				MMY-MAP2006HT8P-E	MMY-MAP2006HT8P-E	MMY-MAP2006HT8P-E
Outdoor unit type				Inverter unit	Inverter unit	Inverter unit
Cooling capacity (*1)			kW	112.0	117.5	123.0
Heating capacity (*1)			kW	126.0	127.0	128.0
Capacity range			HP	40	42	44
Power supply				3N~ 50Hz 400V(380-415V)	3N~ 50Hz 400V(380-415V)	3N~ 50Hz 400V(380-415V)
Voltage range (*2)		Minimum	V	342	342	342
		Maximum	V	456	456	456
Electrical characteristic (*1)	Cooling	Running current	A	53.60	62.40	71.20
		Power input	kW	34.60	40.50	46.40
		EER	kW/kW	3.24	2.90	2.65
	Heating	Running current	A	52.20	55.30	58.40
		Power input	kW	34.00	35.80	37.60
		COP	kW/kW	3.71	3.55	3.40
Starting current		A	Soft Start	Soft Start	Soft Start	
Weight	Heat pump	kg		371 + 371	371 + 371	371 + 371
Colour				Silky shade (Munsell 1Y8.5/0.5)	Silky shade (Munsell 1Y8.5/0.5)	Silky shade (Munsell 1Y8.5/0.5)
Compressor	Type			Hermetic twin rotary compressor	Hermetic twin rotary compressor	Hermetic twin rotary compressor
	Motor output	kW		7.6x2 + 7.6x2	9.0x2 + 7.6x2	9.0x2 + 9.0x2
Fan unit	Fan			Propeller fan	Propeller fan	Propeller fan
	Motor output	kW		2.0 + 2.0	2.0 + 2.0	2.0 + 2.0
	Air volume	m3/h		17900 + 17900	18500 + 17900	18500 + 18500
Max. external static pressure			Pa	40	40	40
Heat exchanger				Finned tube	Finned tube	Finned tube
Refrigerant	Name			R410A	R410A	R410A
	Charge	Heat pump	kg	11.5 + 11.5	11.5 + 11.5	11.5 + 11.5
High-pressure switch			Pa	OFF:3.2 ON:4.15	OFF:3.2 ON:4.15	OFF:3.2 ON:4.15
Protective devices				(*3)	(*3)	(*3)
Power supply wiring		MCA (*4)	A	89.8	94.2	98.6
		MOCP (*5)	A	100.0	125.0	125.0
Piping connections	Gas	Type		Brazing	Brazing	Brazing
		Diameter	mm	41.3	41.3	41.3
	Liquid	Type		Flare	Flare	Flare
		Diameter	mm	22.2	22.2	22.2
	Balance	Type		Flare	Flare	Flare
		Diameter	mm	9.5	9.5	9.5
Max. number of connected indoor units				64	64	64
Sound pressure level	Cooling	dB(A)		64.0	64.0	64.0
	Heating	dB(A)		65.0	65.0	65.0
Sound power level	Cooling	dB(A)		85.0	85.5	86.0
	Heating	dB(A)		87.0	87.0	87.0
Operation temperature range	Cooling	CDB		-5.0 to 46.0	-5.0 to 46.0	-5.0 to 46.0
	Heating(*6)	CWB		-25.0 to 15.5	-25.0 to 15.5	-25.0 to 15.5

Note

(*1) Rated conditions

Cooling : Indoor 27 degC Dry Bulb /19 degC Wet Bulb , Outdoor 35 degC Dry Bulb.

Heating : Indoor 20 degC Dry Bulb, Outdoor 7 degC Dry Bulb / 6 degC WetBulb.

Based on equivalent piping length of 7.5m and piping height difference of 0m.

(*2) Voltage range : Units are suitable for use on electrical systems where voltage supplied to unit terminal is not below or above listed range limits.

(*3) Discharge temp. sensor / Suction temp. sensor / High-pressure sensor / Low-pressure sensor / Compressor case thermostat / PC board fuse

(*4) Select wire size base on the larger value of MCA.

MCA : Minimum Circuit Amps

(*5) MOCP : Maximum Overcurrent Protection(Amps)

(*6) Low ambient heating (-20degC or less) for extended periods of time is not allowed



Model	Name	Heat pump		MMY-AP4616HT8P-E	MMY-AP4816HT8P-E	MMY-AP5016HT8P-E
	Combination	Heat pump		MMY-MAP1606HT8P-E	MMY-MAP1606HT8P-E	MMY-MAP1806HT8P-E
				MMY-MAP1606HT8P-E	MMY-MAP1606HT8P-E	MMY-MAP1606HT8P-E
				MMY-MAP1406HT8P-E	MMY-MAP1606HT8P-E	MMY-MAP1606HT8P-E
Outdoor unit type				Inverter unit	Inverter unit	Inverter unit
Cooling capacity (*1)			kW	130.0	135.0	140.4
Heating capacity (*1)			kW	145.0	150.0	156.0
Capacity range			HP	46	48	50
Power supply				3N~ 50Hz 400V(380-415V)	3N~ 50Hz 400V(380-415V)	3N~ 50Hz 400V(380-415V)
Voltage range (*2)		Minimum	V	342	342	342
		Maximum	V	456	456	456
Electrical characteristic (*1)	Cooling	Running current	A	64.3	67.2	67.7
		Power input	kW	40.9	42.9	43.2
		EER	kW/kW	3.18	3.15	3.25
	Heating	Running current	A	58.2	60.6	62.5
		Power input	kW	37.0	38.7	39.9
		COP	kW/kW	3.92	3.88	3.91
Starting current		A	Soft Start	Soft Start	Soft Start	
Weight	Heat pump		kg	300 + 300 + 300	300 + 300 + 300	371 + 300 + 300
Colour				Silky shade (Munsell 1Y8.5/0.5)	Silky shade (Munsell 1Y8.5/0.5)	Silky shade (Munsell 1Y8.5/0.5)
Compressor	Type			Hermetic twin rotary compressor	Hermetic twin rotary compressor	Hermetic twin rotary compressor
	Motor output		kW	5.8x2 + 5.8x2 + 4.8x2	5.8x2 + 5.8x2 + 5.8x2	6.5x2 + 5.8x2 + 5.8x2
Fan unit	Fan			Propeller fan	Propeller fan	Propeller fan
	Motor output		kW	1.0 + 1.0 + 1.0	1.0 + 1.0 + 1.0	2.0 + 1.0 + 1.0
	Air volume		m ³ /h	12600 + 12600 + 12200	12600 + 12600 + 12600	17300 + 12600 + 12600
Max. external static pressure			Pa	40	40	40
Heat exchanger				Finned tube	Finned tube	Finned tube
Refrigerant	Name			R410A	R410A	R410A
	Charge	Heat pump	kg	11.5 + 11.5 + 11.5	11.5 + 11.5 + 11.5	11.5 + 11.5 + 11.5
High-pressure switch			Pa	OFF:3.2 ON:4.15	OFF:3.2 ON:4.15	OFF:3.2 ON:4.15
Protective devices				(*3)	(*3)	(*3)
Power supply wiring		MCA (*4)	A	102.6	107.4	112.2
		MOCP (*5)	A	125.0	125.0	125.0
Piping connections	Gas	Type		Brazing	Brazing	Brazing
		Diameter	mm	41.3	41.3	41.3
	Liquid	Type		Flare	Flare	Flare
		Diameter	mm	22.2	22.2	22.2
	Balance	Type		Flare	Flare	Flare
		Diameter	mm	9.5	9.5	9.5
Max. number of connected indoor units				64	64	64
Sound pressure level		Cooling	dB(A)	66.5	67.0	66.5
		Heating	dB(A)	68.5	69.0	68.0
Sound power level		Cooling	dB(A)	85.5	86.0	86.0
		Heating	dB(A)	87.5	88.0	88.0
Operation temperature range		Cooling	CDB	-5.0 to 46.0	-5.0 to 46.0	-5.0 to 46.0
		Heating(*6)	CWB	-25.0 to 15.5	-25.0 to 15.5	-25.0 to 15.5

Note

(*1) Rated conditions

Cooling : Indoor 27 degC Dry Bulb /19 degC Wet Bulb , Outdoor 35 degC Dry Bulb.

Heating : Indoor 20 degC Dry Bulb , Outdoor 7 degC Dry Bulb / 6 degC WetBulb.

Based on equivalent piping length of 7.5m and piping height difference of 0m.

(*2) Voltage range : Units are suitable for use on electrical systems where voltage supplied to unit terminal is not below or above listed range limits.

(*3) Discharge temp. sensor / Suction temp. sensor / High-pressure sensor / Low-pressure sensor / Compressor case thermostat / PC board fuse

(*4) Select wire size base on the larger value of MCA.

MCA : Minimum Circuit Amps

(*5) MOCP : Maximum Overcurrent Protection(Amps)

(*6) Low ambient heating (-20degC or less) for extended periods of time is not allowed



Model	Name	Heat pump		MMY-AP5216HT8P-E	MMY-AP5416HT8P-E	MMY-AP5616HT8P-E	
	Combination	Heat pump		MMY-MAP2006HT8P-E	MMY-MAP206HT8P-E	MMY-MAP2006HT8P-E	
				MMY-MAP1606HT8P-E	MMY-MAP1606HT8P-E	MMY-MAP2006HT8P-E	
				MMY-MAP1606HT8P-E	MMY-MAP1606HT8P-E	MMY-MAP1606HT8P-E	
Outdoor unit type				Inverter unit	Inverter unit	Inverter unit	
Cooling capacity (*1)			kW	146.0	151.5	157.0	
Heating capacity (*1)			kW	163.0	164.0	176.0	
Capacity range			HP	52	54	56	
Power supply				3N~ 50Hz 400V(380-415V)		3N~ 50Hz 400V(380-415V)	
Voltage range (*2)		Minimum	V	342	342	342	
		Maximum	V	456	456	456	
Electrical characteristic (*1)	Cooling	Running current	A	71.6	80.4	76.0	
		Power input	kW	45.9	51.8	48.9	
		EER	kW/kW	3.18	2.92	3.21	
	Heating	Running current	A	66.5	69.6	72.4	
		Power input	kW	42.8	44.6	46.9	
		COP	kW/kW	3.81	3.68	3.75	
	Starting current		A	Soft Start		Soft Start	
Weight	Heat pump	kg	371 + 300 + 300	371 + 300 + 300	371 + 371 + 300		
Colour				Silky shade (Munsell 1Y8.5/0.5)		Silky shade (Munsell 1Y8.5/0.5)	
Compressor	Type		Hermetic twin rotary compressor		Hermetic twin rotary compressor		
	Motor output	kW	7.6x2 + 5.8x2 + 5.8x2	9.0x2 + 5.8x2 + 5.8x2	7.6x2 + 7.6x2 + 5.8x2		
Fan unit	Fan		Propeller fan		Propeller fan		
	Motor output	kW	2.0 + 1.0 + 1.0	2.0 + 1.0 + 1.0	2.0 + 2.0 + 1.0		
	Air volume	m ³ /h	17900 + 12600 + 12600	18500 + 12600 + 12600	17900 + 17900 + 12600		
Max. external static pressure			Pa	40	40	40	
Heat exchanger				Finned tube		Finned tube	
Refrigerant	Name			R410A		R410A	
	Charge	Heat pump	kg	11.5 + 11.5 + 11.5	11.5 + 11.5 + 11.5	11.5 + 11.5 + 11.5	
High-pressure switch			Pa	OFF:3.2 ON:4.15		OFF:3.2 ON:4.15	
Protective devices				(*3)		(*3)	
Power supply wiring		MCA (*4)	A	116.5	120.9	125.6	
		MOCP (*5)	A	160.0	160.0	160.0	
Piping connections	Gas	Type		Brazeing		Brazeing	
		Diameter	mm	41.3	41.3	41.3	
	Liquid	Type		Flare		Flare	
		Diameter	mm	22.2	22.2	22.2	
	Balance	Type		Flare		Flare	
		Diameter	mm	9.5	9.5	9.5	
Max. number of connected indoor units				64		64	
Sound pressure level		Cooling	dB(A)	66.5	66.5	66.5	
		Heating	dB(A)	68.5	68.5	67.5	
Sound power level		Cooling	dB(A)	86.5	86.5	86.5	
		Heating	dB(A)	88.5	88.5	88.5	
Operation temperature range		Cooling	CDB	-5.0 to 46.0		-5.0 to 46.0	
		Heating(*6)	CWB	-25.0 to 15.5		-25.0 to 15.5	

Note

(*1) Rated conditions

Cooling : Indoor 27 degC Dry Bulb /19 degC Wet Bulb , Outdoor 35 degC Dry Bulb.

Heating : Indoor 20 degC Dry Bulb, Outdoor 7 degC Dry Bulb / 6 degC WetBulb.

Based on equivalent piping length of 7.5m and piping height difference of 0m.

(*2) Voltage range : Units are suitable for use on electrical systems where voltage supplied to unit terminal is not below or above listed range limits.

(*3) Discharge temp. sensor / Suction temp. sensor / High-pressure sensor / Low-pressure sensor / Compressor case thermostat / PC board fuse

(*4) Select wire size base on the larger value of MCA.

MCA : Minimum Circuit Amps

(*5) MOCP : Maximum Overcurrent Protection(Amps)

(*6) Low ambient heating (-20degC or less) for extended periods of time is not allowed



Model	Name	Heat pump		MMY-AP5816HT8P-E	MMY-AP6016HT8P-E
	Combination	Heat pump		MMY-MAP2206HT8P-E	MMY-MAP2206HT8P-E
				MMY-MAP2006HT8P-E	MMY-MAP2206HT8P-E
				MMY-MAP1606HT8P-E	MMY-MAP1606HT8P-E
Outdoor unit type			Inverter unit		Inverter unit
Cooling capacity (*1)			kW	162.5	168.0
Heating capacity (*1)			kW	177.0	178.0
Capacity range			HP	58	60
Power supply			3N~ 50Hz 400V(380-415V)		3N~ 50Hz 400V(380-415V)
Voltage range (*2)		Minimum	V	342	342
		Maximum	V	456	456
Electrical characteristic (*1)	Cooling	Running current	A	84.8	93.6
		Power input	kW	54.8	60.7
		EER	kW/kW	2.97	2.77
	Heating	Running current	A	75.5	78.6
		Power input	kW	48.7	50.5
		COP	kW/kW	3.63	3.52
Starting current		A	Soft Start		
Weight	Heat pump	kg	371 + 371 + 300		371 + 371 + 300
Colour			Silky shade (Munsell 1Y8.5/0.5)		Silky shade (Munsell 1Y8.5/0.5)
Compressor	Type		Hermetic twin rotary compressor		Hermetic twin rotary compressor
	Motor output		kW	9.0x2 + 7.6x2 + 5.8x2	9.0x2 + 9.0x2 + 5.8x2
Fan unit	Fan		Propeller fan		Propeller fan
	Motor output		kW	2.0 + 2.0 + 1.0	2.0 + 2.0 + 1.0
	Air volume		m3/h	18500 + 17900 + 12600	18500 + 18500 + 12600
Max. external static pressure			Pa	40	40
Heat exchanger			Finned tube		Finned tube
Refrigerant	Name		R410A		R410A
	Charge	Heat pump	kg	11.5 + 11.5 + 11.5	11.5 + 11.5 + 11.5
High-pressure switch			Pa	OFF:3.2 ON:4.15	OFF:3.2 ON:4.15
Protective devices			(*3)		(*3)
Power supply wiring		MCA (*4)	A	130.0	134.4
		MOCP (*5)	A	160.0	160.0
Piping connections	Gas	Type	Brazing		Brazing
		Diameter	mm	41.3	41.3
	Liquid	Type	Flare		Flare
		Diameter	mm	22.2	22.2
	Balance	Type	Flare		Flare
		Diameter	mm	9.5	9.5
Max. number of connected indoor units			64		64
Sound pressure level		Cooling	dB(A)	66.5	66.5
		Heating	dB(A)	67.5	67.5
Sound power level		Cooling	dB(A)	87.0	87.5
		Heating	dB(A)	88.5	88.5
Operation temperature range		Cooling	CDB	-5.0 to 46.0	-5.0 to 46.0
		Heating(*6)	CWB	-25.0 to 15.5	-25.0 to 15.5

Note

(*1) Rated conditions

Cooling : Indoor 27 degC Dry Bulb /19 degC Wet Bulb , Outdoor 35 degC Dry Bulb.

Heating : Indoor 20 degC Dry Bulb, Outdoor 7 degC Dry Bulb / 6 degC WetBulb.

Based on equivalent piping length of 7.5m and piping height difference of 0m.

(*2) Voltage range : Units are suitable for use on electrical systems where voltage supplied to unit terminal is not below or above listed range limits.

(*3) Discharge temp. sensor / Suction temp. sensor / High-pressure sensor / Low-pressure sensor / Compressor case thermostat / PC board fuse

(*4) Select wire size base on the larger value of MCA.

MCA : Minimum Circuit Amps

(*5) MOCP : Maximum Overcurrent Protection(Amps)

(*6) Low ambient heating (-20degC or less) for extended periods of time is not allowed



High efficiency / Heating capacity priority model

Model	Name	Heat pump		MMY-AP2026HT8P-E	MMY-AP2226HT8P-E
	Combination	Heat pump		MMY-MAP1006HT8P-E	MMY-MAP1206HT8P-E
Outdoor unit type				Inverter unit	Inverter unit
Cooling capacity (*1)			kW	56.0	61.5
Heating capacity (*1)			kW	63.0	69.0
Capacity range			HP	20	22
Power supply				3N~ 50Hz 400V(380-415V)	3N~ 50Hz 400V(380-415V)
Voltage range (*2)		Minimum	V	342	342
		Maximum	V	456	456
Electrical characteristic (*1)	Cooling	Running current	A	24.2	27.6
		Power input	kW	15.4	17.7
		EER	kW/kW	3.64	3.48
	Heating	Running current	A	23.2	26.6
		Power input	kW	14.8	17.1
		COP	kW/kW	4.25	4.04
Starting current		A	Soft Start	Soft Start	
Weight	Heat pump		kg	242 + 242	242 + 242
Colour				Silky shade (Munsell 1Y8.5/0.5)	Silky shade (Munsell 1Y8.5/0.5)
Compressor	Type			Hermetic twin rotary compressor	Hermetic twin rotary compressor
	Motor output		kW	3.1x2 + 3.1x2	3.9x2 + 3.1x2
Fan unit	Fan			Propeller fan	Propeller fan
	Motor output		kW	1.0 + 1.0	1.0 + 1.0
	Air volume		m3/h	9700 + 9700	12200 + 9700
Max. external static pressure			Pa	60	50
Heat exchanger				Finned tube	Finned tube
Refrigerant	Name			R410A	R410A
	Charge	Heat pump	kg	11.5 + 11.5	11.5 + 11.5
High-pressure switch			Pa	OFF:3.2 ON:4.15	OFF:3.2 ON:4.15
Protective devices				(*3)	(*3)
Power supply wiring		MCA (*4)	A	43.0	47.6
		MOCP (*5)	A	50.0	63.0
Piping connections	Gas	Type		Brazing	Brazing
		Diameter	mm	28.6	28.6
	Liquid	Type		Flare	Flare
		Diameter	mm	15.9 or 12.7 (*7)	19.1 or 15.9 (*7)
	Balance	Type		Flare	Flare
		Diameter	mm	9.5	9.5
Max. number of connected indoor units				45	49
Sound pressure level		Cooling	dB(A)	60.0	61.5
		Heating	dB(A)	61.0	63.0
Sound power level		Cooling	dB(A)	77.0	81.0
		Heating	dB(A)	77.0	83.0
Operation temperature range		Cooling	CDB	-5.0 to 46.0	-5.0 to 46.0
		Heating(*6)	CWB	-25.0 to 15.5	-25.0 to 15.5

Note

(*1) Rated conditions

Cooling : Indoor 27 degC Dry Bulb /19 degC Wet Bulb , Outdoor 35 degC Dry Bulb.

Heating : Indoor 20 degC Dry Bulb, Outdoor 7 degC Dry Bulb / 6 degC WetBulb.

Based on equivalent piping length of 7.5m and piping height difference of 0m.

(*2) Voltage range : Units are suitable for use on electrical systems where voltage supplied to unit terminal is not below or above listed range limits.

(*3) Discharge temp. sensor / Suction temp. sensor / High-pressure sensor / Low-pressure sensor / Compressor case thermostat / PC board fuse

(*4) Select wire size base on the larger value of MCA.

MCA : Minimum Circuit Amps

(*5) MOCP : Maximum Overcurrent Protection(Amps)

(*6) Low ambient heating (-20degC or less) for extended periods of time is not allowed

(*7) This pipe size can be used in refrigerant saving condition. Refrigerant saving condition can be adopted under all the conditions below,

- Real length of main piping (L1) : 50m or less
- Height difference between outdoor and indoor units (H1) : 30m or less
- Total capacity codes of all outdoor units is 14HP to below 46HP.



Model	Name	Heat pump		MMY-AP3626HT8P-E	MMY-AP3826HT8P-E	MMY-AP4026HT8P-E
	Combination	Heat pump		MMY-MAP1206HT8P-E	MMY-MAP1406HT8P-E	MMY-MAP1406HT8P-E
				MMY-MAP1206HT8P-E	MMY-MAP1206HT8P-E	MMY-MAP1406HT8P-E
				MMY-MAP1206HT8P-E	MMY-MAP1206HT8P-E	MMY-MAP1206HT8P-E
Outdoor unit type				Inverter unit	Inverter unit	Inverter unit
Cooling capacity (*1)			kW	100.5	107.0	113.5
Heating capacity (*1)			kW	112.5	120.0	127.5
Capacity range			HP	36	38	40
Power supply				3N~ 50Hz 400V(380-415V)	3N~ 50Hz 400V(380-415V)	3N~ 50Hz 400V(380-415V)
Voltage range (*2)		Minimum	V	342	342	342
		Maximum	V	456	456	456
Electrical characteristic (*1)	Cooling	Running current	A	46.5	50.5	54.5
		Power input	kW	30.0	32.3	34.6
		EER	kW/kW	3.35	3.31	3.28
	Heating	Running current	A	45.0	47.8	50.6
		Power input	kW	29.0	30.5	32.1
		COP	kW/kW	3.89	3.93	3.98
Starting current		A	Soft Start	Soft Start	Soft Start	
Weight	Heat pump		kg	242 + 242 + 242	300 + 242 + 242	300 + 300 + 242
Colour				Silky shade (Munsell 1Y8.5/0.5)	Silky shade (Munsell 1Y8.5/0.5)	Silky shade (Munsell 1Y8.5/0.5)
Compressor	Type			Hermetic twin rotary compressor	Hermetic twin rotary compressor	Hermetic twin rotary compressor
	Motor output		kW	3.9x2 + 3.9x2 + 3.9x2	4.8x2 + 3.9x2 + 3.9x2	4.8x2 + 4.8x2 + 3.9x2
Fan unit	Fan			Propeller fan	Propeller fan	Propeller fan
	Motor output		kW	1.0 + 1.0 + 1.0	1.0 + 1.0 + 1.0	1.0 + 1.0 + 1.0
	Air volume		m ³ /h	12200 + 12200 + 12200	12200 + 12200 + 12200	12200 + 12200 + 12200
Max. external static pressure			Pa	50	50	50
Heat exchanger				Finned tube	Finned tube	Finned tube
Refrigerant	Name			R410A	R410A	R410A
	Charge	Heat pump	kg	11.5 + 11.5 + 11.5	11.5 + 11.5 + 11.5	11.5 + 11.5 + 11.5
High-pressure switch			Pa	OFF:3.2 ON:4.15	OFF:3.2 ON:4.15	OFF:3.2 ON:4.15
Protective devices				(*3)	(*3)	(*3)
Power supply wiring		MCA (*4)	A	78.3	83.2	88.1
		MOCP (*5)	A	100.0	100.0	100.0
Piping connections	Gas	Type		Brazing	Brazing	Brazing
		Diameter	mm	41.3	41.3	41.3
	Liquid	Type		Flare	Flare	Flare
		Diameter	mm	22.2 or 19.1 (*7)	22.2 or 19.1 (*7)	22.2 or 19.1 (*7)
	Balance	Type		Flare	Flare	Flare
		Diameter	mm	9.5	9.5	9.5
Max. number of connected indoor units				64	64	64
Sound pressure level		Cooling	dB(A)	64.0	64.5	64.5
		Heating	dB(A)	66.0	66.5	66.5
Sound power level		Cooling	dB(A)	85.0	85.0	85.0
		Heating	dB(A)	87.0	87.0	87.0
Operation temperature range		Cooling	CDB	-5.0 to 46.0	-5.0 to 46.0	-5.0 to 46.0
		Heating(*6)	CWB	-25.0 to 15.5	-25.0 to 15.5	-25.0 to 15.5

Note

(*1) Rated conditions

Cooling : Indoor 27 degC Dry Bulb /19 degC Wet Bulb , Outdoor 35 degC Dry Bulb.

Heating : Indoor 20 degC Dry Bulb , Outdoor 7 degC Dry Bulb / 6 degC WetBulb.

Based on equivalent piping length of 7.5m and piping height difference of 0m.

(*2) Voltage range : Units are suitable for use on electrical systems where voltage supplied to unit terminal is not below or above listed range limits.

(*3) Discharge temp. sensor / Suction temp. sensor / High-pressure sensor / Low-pressure sensor / Compressor case thermostat / PC board fuse

(*4) Select wire size base on the larger value of MCA.

MCA : Minimum Circuit Amps

(*5) MOCP : Maximum Overcurrent Protection(Amps)

(*6) Low ambient heating (-20degC or less) for extended periods of time is not allowed

(*7) This pipe size can be used in refrigerant saving condition. Refrigerant saving condition can be adopted under all the conditions below,

- Real length of main piping (L1) : 50m or less
- Height difference between outdoor and indoor units (H1) : 30m or less
- Total capacity codes of all outdoor units is 14HP to below 46HP.



Model	Name	Heat pump		MMY-AP4226HT8P-E	MMY-AP4426HT8P-E	MMY-AP5426HT8P-E
	Combination	Heat pump		MMY-MAP1406HT8P-E	MMY-MAP1606HT8P-E	MMY-MAP2006HT8P-E
				MMY-MAP1406HT8P-E	MMY-MAP1406HT8P-E	MMY-MAP2006HT8P-E
				MMY-MAP1406HT8P-E	MMY-MAP1406HT8P-E	MMY-MAP1406HT8P-E
Outdoor unit type				Inverter unit	Inverter unit	Inverter unit
Cooling capacity (*1)			kW	120.0	125.0	152.0
Heating capacity (*1)			kW	135.0	140.0	171.0
Capacity range			HP	42	44	54
Power supply				3N~ 50Hz 400V(380-415V)	3N~ 50Hz 400V(380-415V)	3N~ 50Hz 400V(380-415V)
Voltage range (*2)		Minimum	V	342	342	342
		Maximum	V	456	456	456
Electrical characteristic (*1)	Cooling	Running current	A	58.5	61.4	73.1
		Power input	kW	36.9	38.9	46.9
		EER	kW/kW	3.25	3.21	3.24
	Heating	Running current	A	53.4	55.8	70.0
		Power input	kW	33.6	35.3	45.2
		COP	kW/kW	4.02	3.97	3.78
Starting current		A	Soft Start	Soft Start	Soft Start	
Weight	Heat pump		kg	300 + 300 + 300	300 + 300 + 300	371 + 371 + 300
Colour				Silky shade (Munsell 1Y8.5/0.5)	Silky shade (Munsell 1Y8.5/0.5)	Silky shade (Munsell 1Y8.5/0.5)
Compressor	Type			Hermetic twin rotary compressor	Hermetic twin rotary compressor	Hermetic twin rotary compressor
	Motor output		kW	4.8x2 + 4.8x2 + 4.8x2	5.8x2 + 4.8x2 + 4.8x2	7.6x2 + 7.6x2 + 4.8x2
Fan unit	Fan			Propeller fan	Propeller fan	Propeller fan
	Motor output		kW	1.0 + 1.0 + 1.0	1.0 + 1.0 + 1.0	2.0 + 2.0 + 1.0
	Air volume		m ³ /h	12200 + 12200 + 12200	12600 + 12200 + 12200	17900 + 17900 + 12200
Max. external static pressure			Pa	50	40	40
Heat exchanger				Finned tube	Finned tube	Finned tube
Refrigerant	Name			R410A	R410A	R410A
	Charge	Heat pump	kg	11.5 + 11.5 + 11.5	11.5 + 11.5 + 11.5	11.5 + 11.5 + 11.5
High-pressure switch			Pa	OFF:3.2 ON:4.15	OFF:3.2 ON:4.15	OFF:3.2 ON:4.15
Protective devices				(*3)	(*3)	(*3)
Power supply wiring		MCA (*4)	A	93.0	97.8	120.8
		MOCP (*5)	A	125.0	125.0	160.0
Piping connections	Gas	Type		Brazing	Brazing	Brazing
		Diameter	mm	41.3	41.3	41.3
	Liquid	Type		Flare	Flare	Flare
		Diameter	mm	22.2 or 19.1 (*7)	22.2 or 19.1 (*7)	22.2
	Balance	Type		Flare	Flare	Flare
		Diameter	mm	9.5	9.5	9.5
Max. number of connected indoor units				64	64	64
Sound pressure level		Cooling	dB(A)	65.0	65.5	65.5
		Heating	dB(A)	67.0	67.5	67.0
Sound power level		Cooling	dB(A)	85.0	85.5	86.5
		Heating	dB(A)	87.0	87.5	88.5
Operation temperature range		Cooling	CDB	-5.0 to 46.0	-5.0 to 46.0	-5.0 to 46.0
		Heating(*6)	CWB	-25.0 to 15.5	-25.0 to 15.5	-25.0 to 15.5

Note

(*1) Rated conditions

Cooling : Indoor 27 degC Dry Bulb /19 degC Wet Bulb , Outdoor 35 degC Dry Bulb.

Heating : Indoor 20 degC Dry Bulb , Outdoor 7 degC Dry Bulb / 6 degC WetBulb.

Based on equivalent piping length of 7.5m and piping height difference of 0m.

(*2) Voltage range : Units are suitable for use on electrical systems where voltage supplied to unit terminal is not below or above listed range limits.

(*3) Discharge temp. sensor / Suction temp. sensor / High-pressure sensor / Low-pressure sensor / Compressor case thermostat / PC board fuse

(*4) Select wire size base on the larger value of MCA.

MCA : Minimum Circuit Amps

(*5) MOCP : Maximum Overcurrent Protection(Amps)

(*6) Low ambient heating (-20degC or less) for extended periods of time is not allowed

(*7) This pipe size can be used in refrigerant saving condition. Refrigerant saving condition can be adopted under all the conditions below,

- Real length of main piping (L1) : 50m or less
- Height difference between outdoor and indoor units (H1) : 30m or less
- Total capacity codes of all outdoor units is 14HP to below 46HP.



Stand alone model

Model name		Heat pump		MMY-S AP0806HT8P-E	MMY-S AP1006HT8P-E	MMY-S AP1206HT8P-E			
Outdoor unit type				Inverter unit		Inverter unit			
Cooling capacity (*1)		kW		22.4	28.0	33.5			
Heating capacity (*1)		kW		25.0	31.5	37.5			
Capacity range		HP		8	10	12			
Power supply				3N~ 50Hz 400V(380-415V)		3N~ 50Hz 400V(380-415V)			
Voltage range (*2)		Minimum		V		342			
		Maximum		V		456			
Electrical characteristic (*1)		Running current		A		8.79			
		Cooling		Power input		kW		5.54	
				EER		kW/kW		4.04	
		Heating		Running current		A		8.96	
				Power input		kW		5.65	
				COP		kW/kW		4.42	
				Starting current		A		Soft Start	
		Dimension		Height		mm		1830	
Width				mm		990			
Depth				mm		780			
Weight		Heat pump		kg		227			
Color				Silky shade (Munsell 1Y8.5/0.5)		Silky shade (Munsell 1Y8.5/0.5)			
Compressor		Type		Hermetic twin rotary compressor		Hermetic twin rotary compressor			
		Motor output		kW		2.1x2			
Fan unit		Type		Propeller fan		Propeller fan			
		Motor output		W		1.0			
		Air volume		m3/h		9700			
Max. external static pressure		Pa		60		60			
Heat exchanger				Finned tube		Finned tube			
Refrigerant		Name		R410A		R410A			
		Charge		kg		5.7			
High-pressure switch		Pa		OFF:3.2 ON:4.15		OFF:3.2 ON:4.15			
Protective devices				(*3)		(*3)			
Power supply wiring		MCA (*4)		A		20.5			
		MOCP (*5)		A		25.0			
Piping connections		Gas		Type		Brazing			
				Diameter		mm		19.1	
		Liquid		Type		Flare			
				Diameter		mm		12.7	
Max. number of connected indoor units				18		22			
Sound pressure level		Cooling		dB(A)		55.0			
		Heating		dB(A)		56.0			
Sound power level		Cooling		dB(A)		74.0			
		Heating		dB(A)		74.0			
Operation temperature range		Cooling(*7)		CDB		-10.0 to 46.0			
		Heating(*6)		CWB		-25.0 to 15.5			

Note

- (*1) Rated conditions
Cooling : Indoor 27 degC Dry Bulb /19 degC Wet Bulb , Outdoor 35 degC Dry Bulb.
Heating : Indoor 20 degC Dry Bulb, Outdoor 7 degC Dry Bulb / 6 degC Wet Bulb.
Based on equivalent piping length of 7.5m and piping height difference of 0m.
- (*2) Voltage range : Units are suitable for use on electrical systems where voltage supplied to unit terminal is not below or above listed range limits.
- (*3) Discharge temp. sensor / Suction temp. sensor / High-pressure sensor / Low-pressure sensor / Compressor case thermostat / PC board fuse
- (*4) Select wire size base on the larger value of MCA.
MCA : Minimum Circuit Amps
- (*5) MOCP : Maximum Overcurrent Protection(Amps)
- (*6) Low ambient heating (-20degC or less) for extended periods of time is not allowed
- (*7) Low ambient cooling (-5 deg C or less) is limited to application.



5-2. Dimensional drawing

Single unit

Model : MMY-MAP0806HT8P-E
 MMY-MAP1006HT8P-E
 MMY-MAP1206HT8P-E

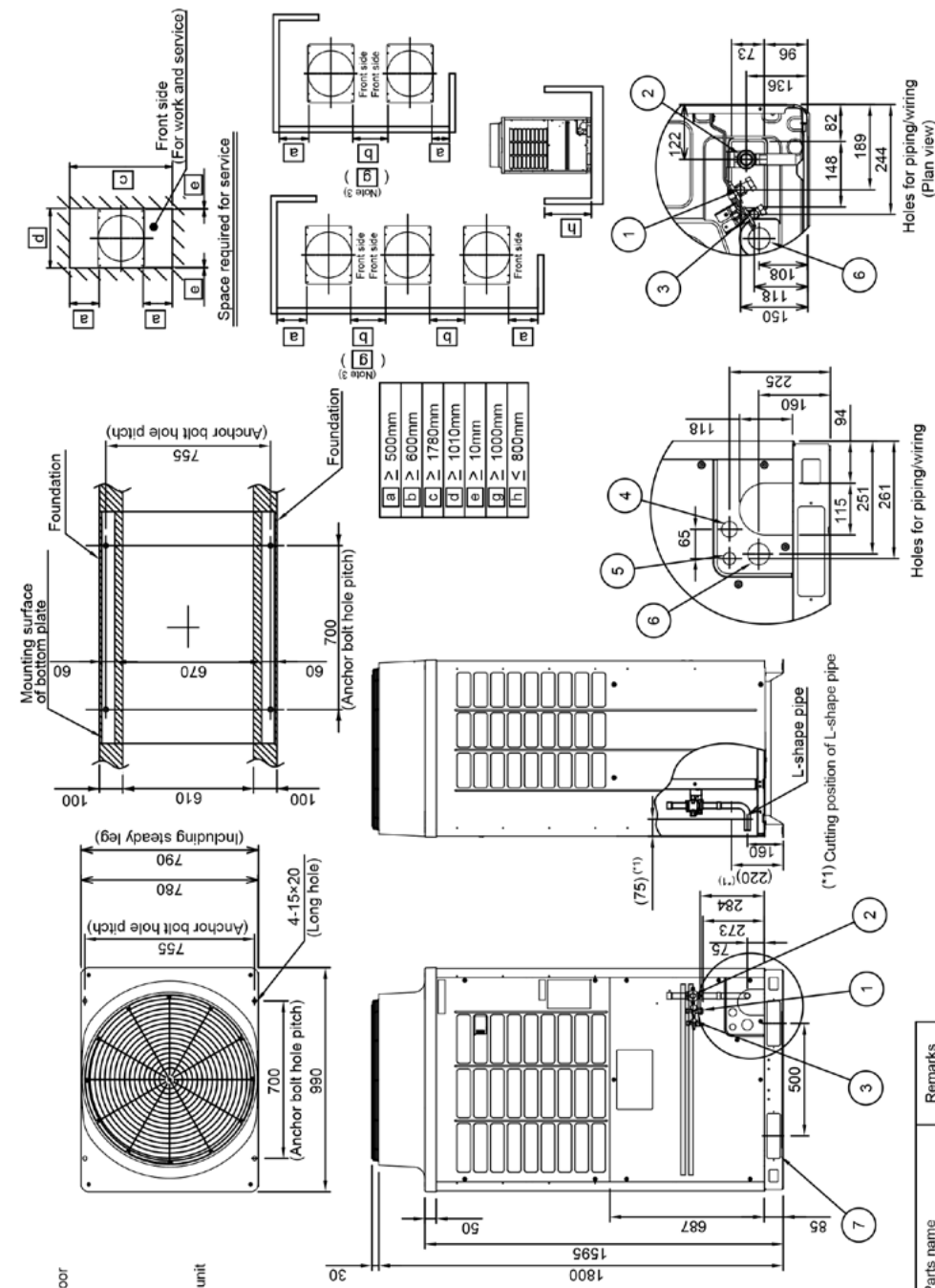

(Note)
 1. If there is an obstacle at the upper side of the outdoor unit, set the top end of the outdoor unit 2000mm apart from the obstacle.
 2. Limit the height of the obstacle surrounding the outdoor unit to 800mm or less from the bottom end of the outdoor unit.
 3. Draw out the pipe procured locally to the front of the outdoor unit horizontally, and keep 500mm or more between the outdoor unit and traversing pipe if placing pipe transversely.
 4. Dimensional drawing of corrosion heavy protection model is the same as that of standard model.



Model : MMY-MAP140HT8P-E
MMY-MAP160HT8P-E

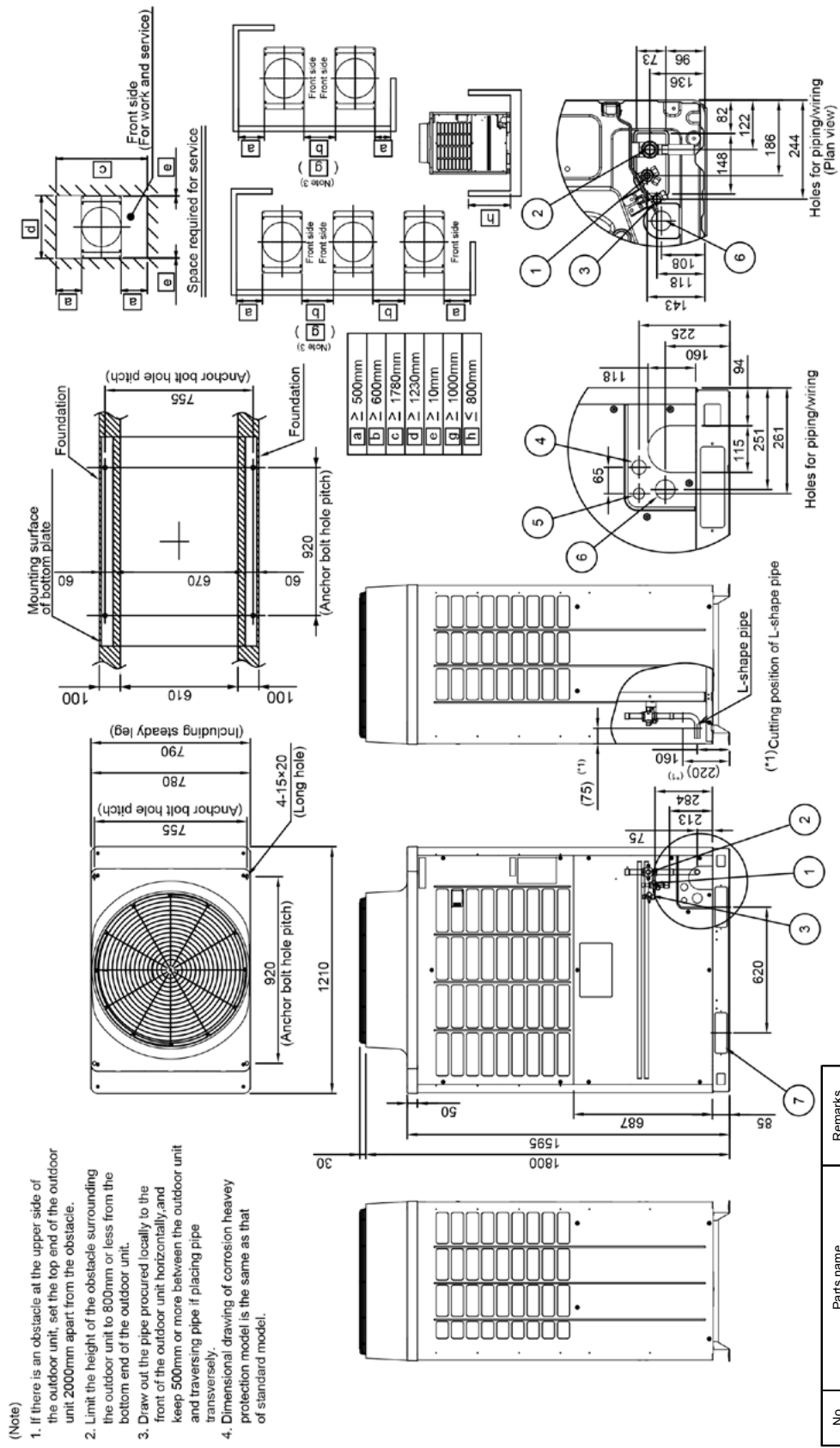



Model : MMY-MAP1806HT8P-E
 MMY-MAP2006HT8P-E
 MMY-MAP2206HT8P-E

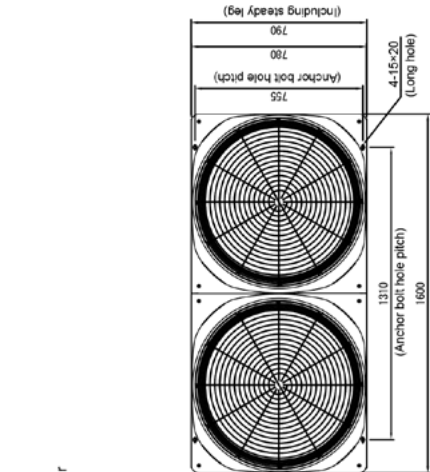
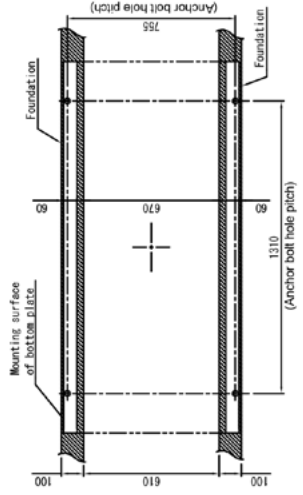
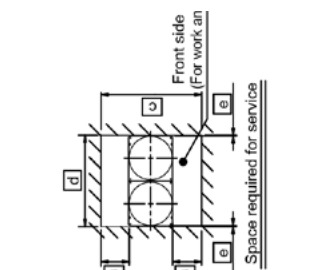

a	≥ 500mm
b	≥ 600mm
c	≥ 1780mm
d	≥ 1230mm
e	≥ 10mm
g	≥ 1000mm
h	≤ 800mm

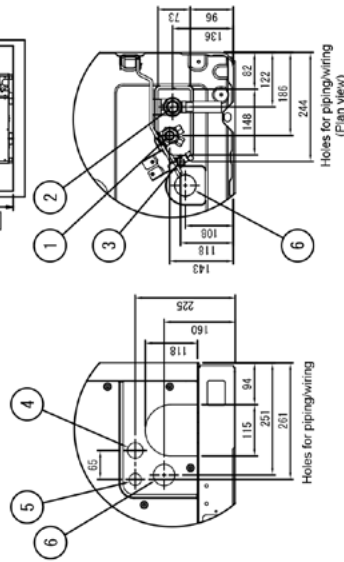
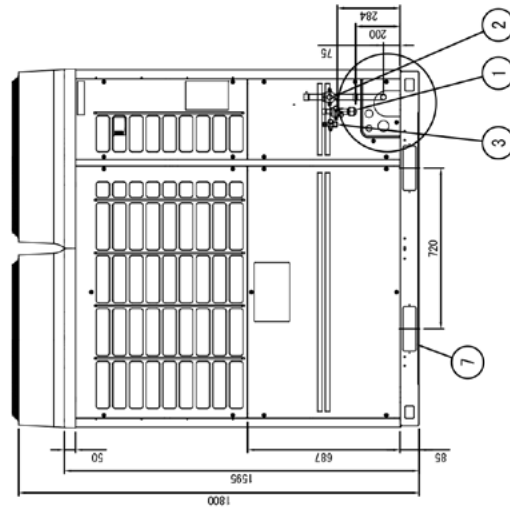
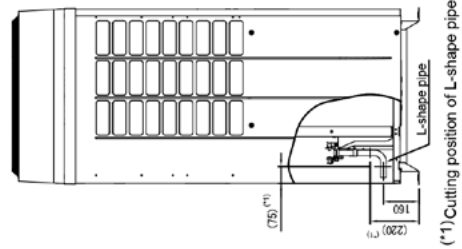

- (Note)
- If there is an obstacle at the upper side of the outdoor unit, set the top end of the outdoor unit 2000mm apart from the obstacle.
 - Limit the height of the obstacle surrounding the outdoor unit to 800mm or less from the bottom end of the outdoor unit.
 - Draw out the pipe procured locally to the front of the outdoor unit horizontally and keep 500mm or more between the outdoor unit and traversing pipe if placing pipe transversely.
 - Dimensional drawing of corrosion heavy protection model is the same as that of standard model.

No	Parts name	Remarks
①	Liquid pipe connection port	ØA
②	Gas pipe connection port	Ø25.6
③	Balance pipe connection port	Ø9.5
④	Knockout hole for power wiring 1	Ø35
⑤	Knockout hole for power wiring	Ø27
⑥	Knockout hole for power wiring 2	Ø48
⑦	Square hole (for freight handling)	2-50x200

Model Name	ØA
MAP1806 type	Ø15.9 or Ø12.7 *
MAP2006 type	Ø15.9 or Ø12.7 *
MAP2206 type	Ø19.1 or Ø15.9 *

* This pipe size can be used in less local refrigerant charge condition.

(Unit : mm)



MMY-SAP0806HT8P-E
MMY-SAP1006HT8P-E
MMY-SAP1206HT8P-E

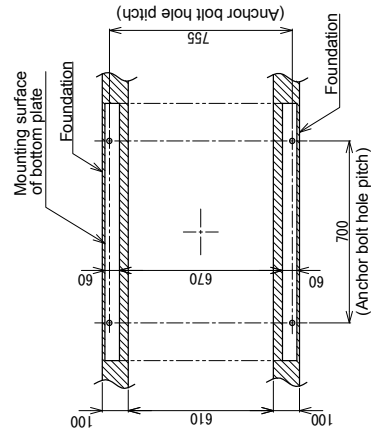
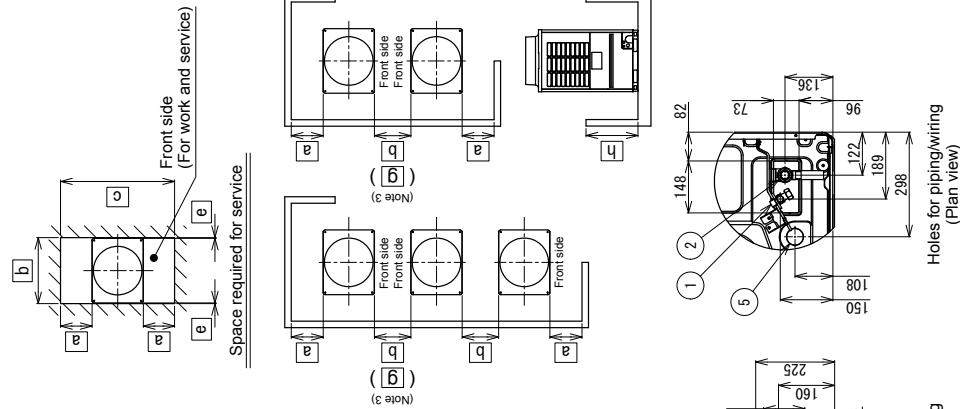

a	≥ 500mm
b	≥ 600mm
c	≥ 1780mm
d	≥ 1010mm
e	≥ 10mm
g	≥ 1000mm
h	≤ 800mm

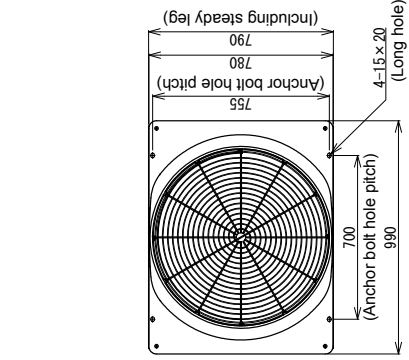
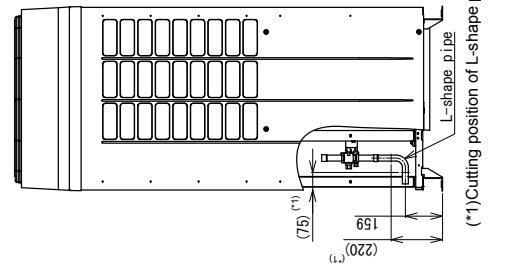

(Note)

- If there is an obstacle at the upper side of the outdoor unit, set the top end of the outdoor unit 2000mm apart from the obstacle.
- Limit the height of the obstacle surrounding the outdoor unit to 800mm or less from the bottom end of the outdoor unit.
- Draw out the pipe procured locally to the front of the outdoor unit horizontally, and keep 500mm or more between the outdoor unit and traversing pipe if placing pipe transversely.
- Dimensional drawing of corrosion heavy protection model is the same as that of standard model.

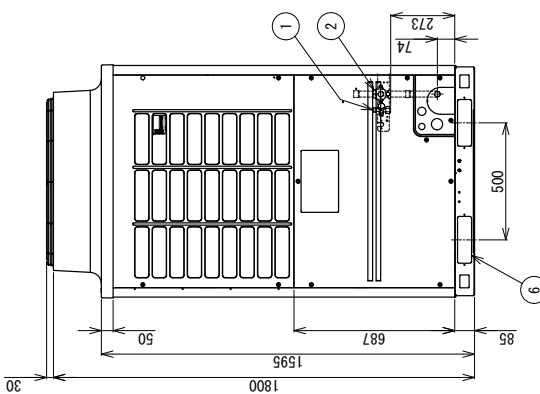

Model name	φA
SAP0806 type	φ19.1
SAP1006 type	φ22.2
SAP1206 type	φ28.6

No.	Parts name	Remarks
①	Liquid pipe connection port	φ12.7
②	Gas pipe connection port	φA
③	Knockout hole for power wiring 1	φ35
④	Knockout hole for control wiring	φ27
⑤	Knockout hole for power wiring 2	φ48
⑥	Square hole (for freight handling)	4-60×200

(Unit : mm)



Combination

(Note) All drawings are common with coding only model (MMY-AP_HT8P-E)

Two units connected

Model	Outdoor unit	
	(1) Header unit	(2) Follower unit
MMY-AP2026HT8P-E	MMY-MAP1006HT8P-E	MMY-MAP1006HT8P-E
MMY-AP2226HT8P-E	MMY-MAP1206HT8P-E	MMY-MAP1006HT8P-E
MMY-AP2416HT8P-E	MMY-MAP1206HT8P-E	MMY-MAP1206HT8P-E

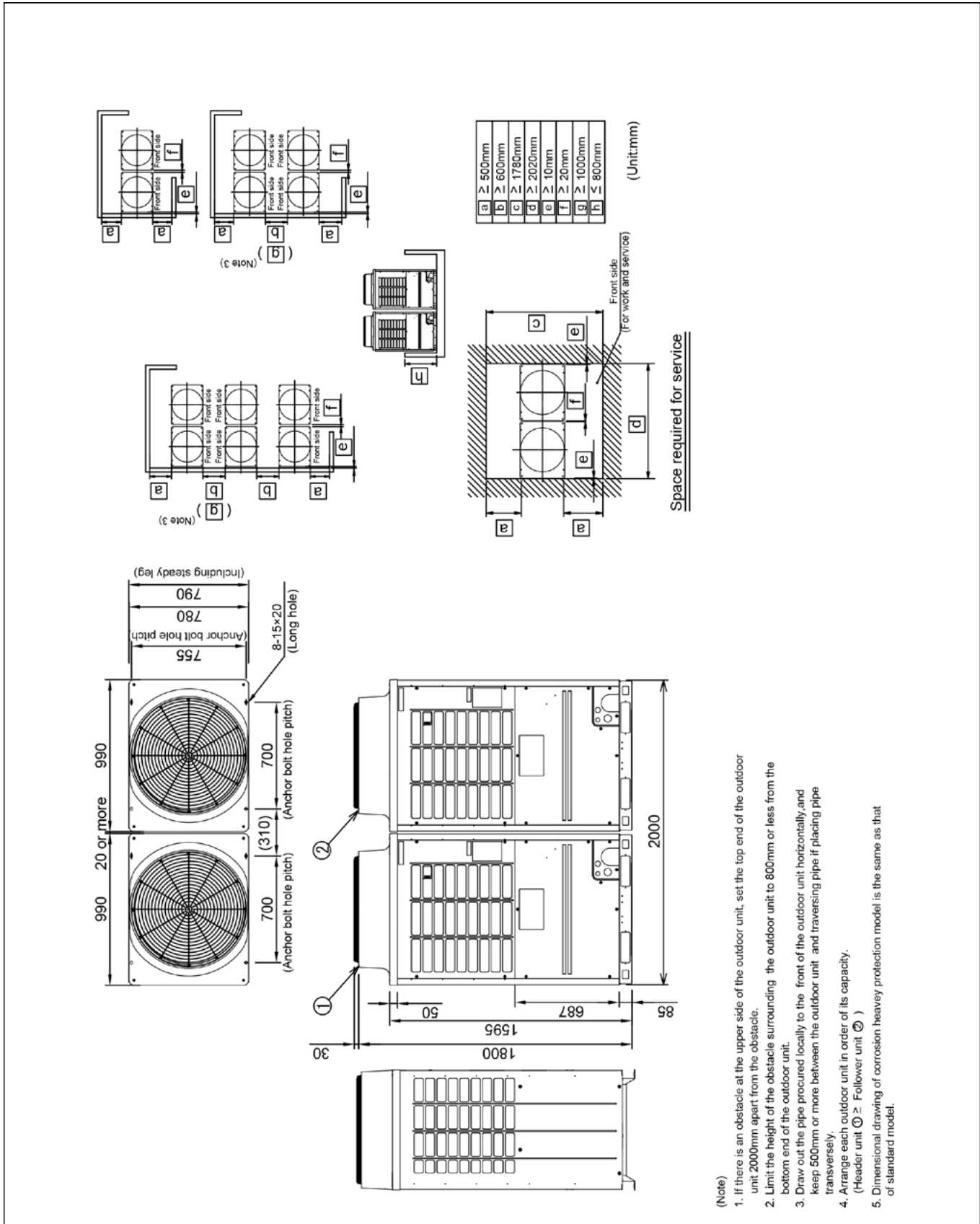

- (Note)
1. If there is an obstacle at the upper side of the outdoor unit, set the top end of the outdoor unit 2000mm apart from the obstacle.
 2. Limit the height of the obstacle surrounding the outdoor unit to 800mm or less from the bottom end of the outdoor unit.
 3. Draw out the pipe procured locally to the front of the outdoor unit horizontally, and keep 500mm or more between the outdoor unit and traversing pipe if placing pipe transversely.
 4. Arrange each outdoor unit in order of its capacity.
(Header unit ① ≥ Follower unit ②)
 5. Dimensional drawing of corrosion heavy protection model is the same as that of standard model.



Model	Outdoor unit	
	(1) Header unit	(2) Follower unit
MMY-AP2616HT8P-E	MMY-MAP1406HT8P-E	MMY-MAP1206HT8P-E
MMY-AP2816HT8P-E	MMY-MAP1606HT8P-E	MMY-MAP1206HT8P-E

Two units connected

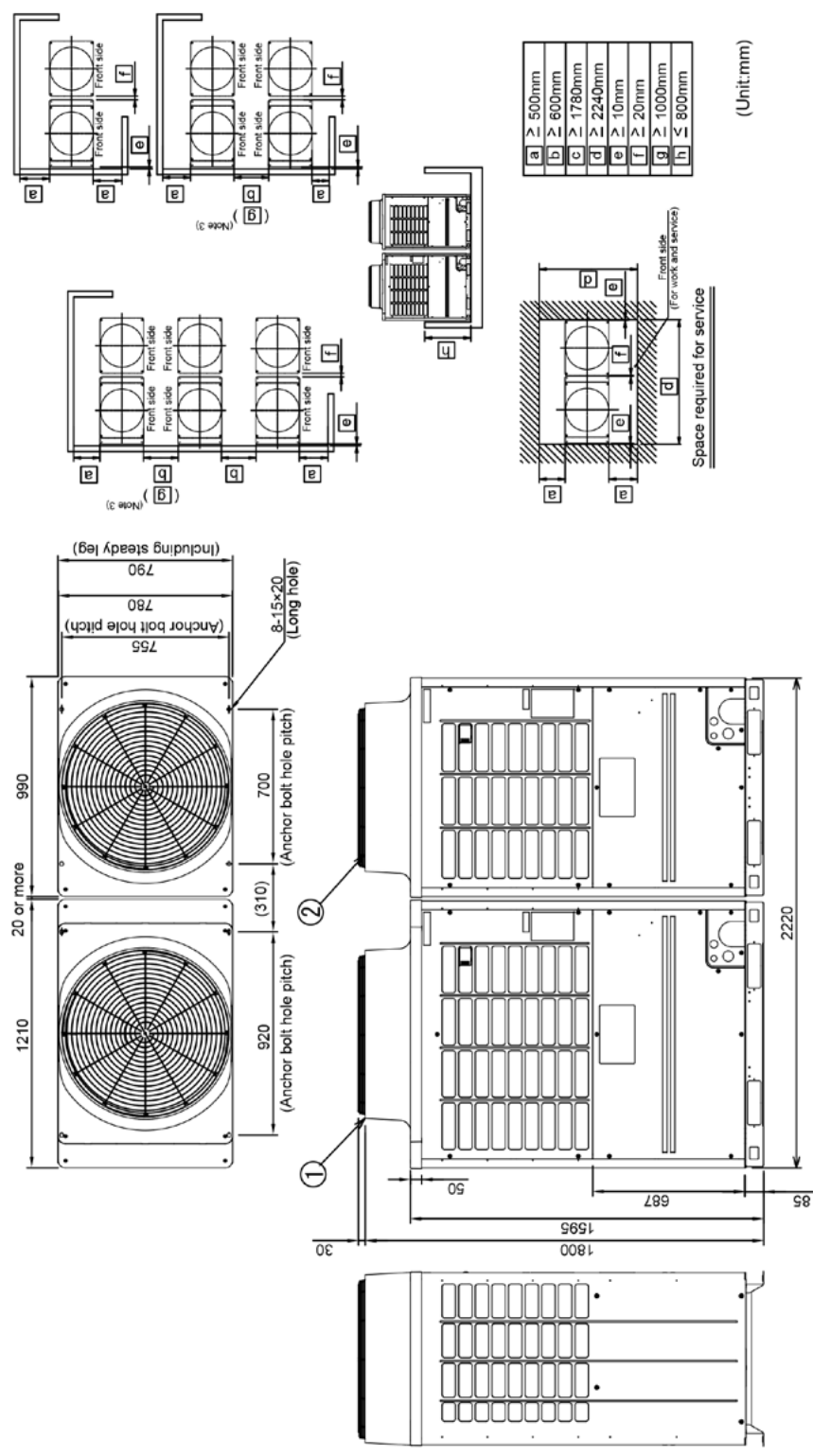

- (Note)
1. If there is an obstacle at the upper side of the outdoor unit, set the top end of the outdoor unit 2000mm apart from the obstacle.
 2. Limit the height of the obstacle surrounding the outdoor unit to 800mm or less from the bottom end of the outdoor unit.
 3. Draw out the pipe procured locally to the front of the outdoor unit horizontally and keep 500mm or more between the outdoor unit and traversing pipe if placing pipe transversely.
 4. Arrange each outdoor unit in order of its capacity.
(Header unit Ⓛ ≥ Follower unit Ⓜ)
 5. Dimensional drawing of corrosion heavy protection model is the same as that of standard model.



Model	Outdoor unit	
	(1) Header unit	(2) Follower unit
MMY-AP3016HT8P-E	MMY-MAP1606HT8P-E	MMY-MAP1406HT8P-E
MMY-AP3216HT8P-E	MMY-MAP1606HT8P-E	MMY-MAP1606HT8P-E

Two units connected

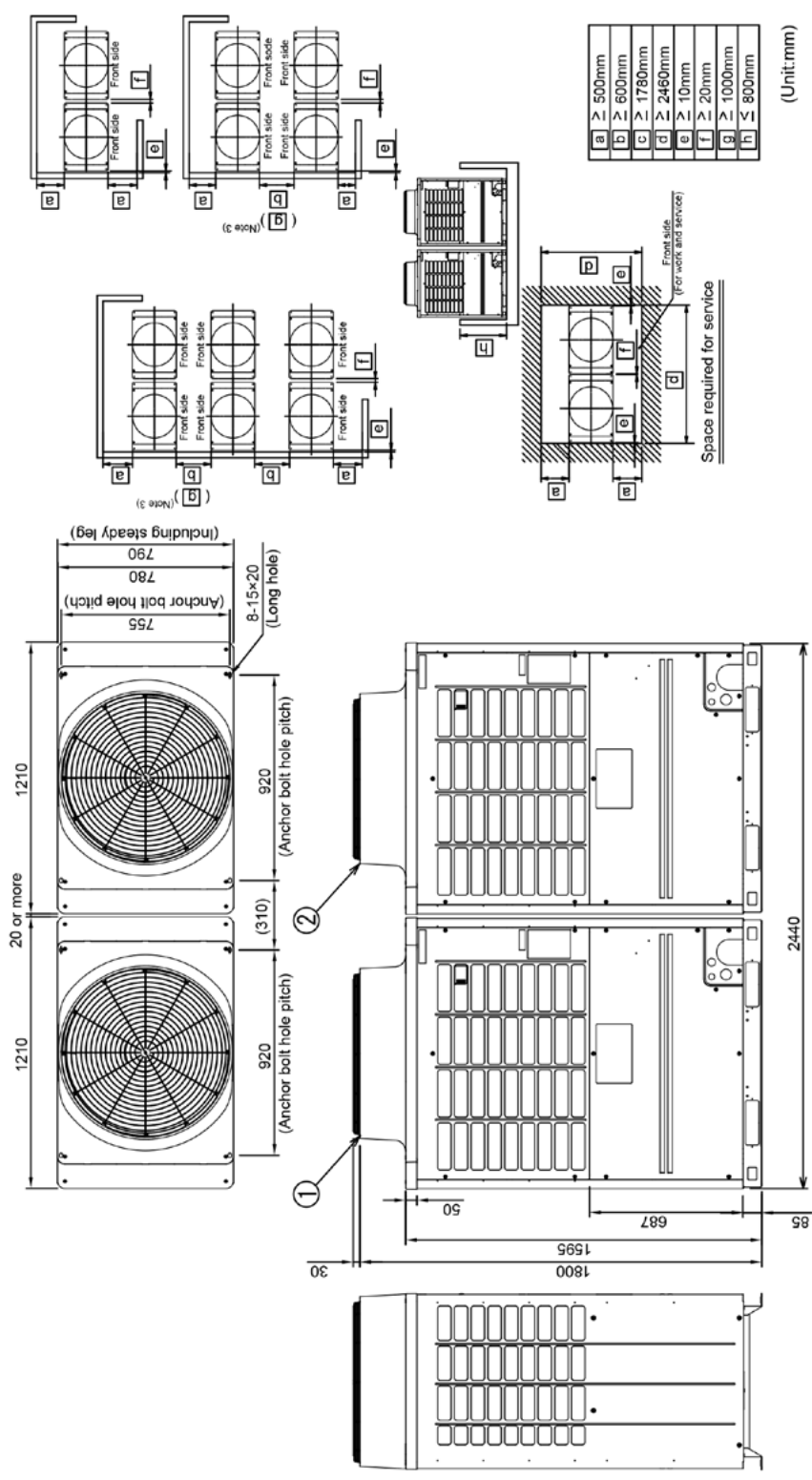

- (Note)
1. If there is an obstacle at the upper side of the outdoor unit, set the top end of the outdoor unit 2000mm apart from the obstacle.
 2. Limit the height of the obstacle surrounding the outdoor unit to 800mm or less from the bottom end of the outdoor unit.
 3. Draw out the pipe procured locally to the front of the outdoor unit horizontally, and keep 500mm or more between the outdoor unit and traversing pipe if placing pipe transversely.
 4. Arrange each outdoor unit in order of its capacity.
 5. Dimensional drawing of corrosion heavy protection model is the same as that of standard model.



Model	Outdoor unit	
	(1) Header unit	(2) Follower unit
MMY-AP3416HT8P-E	MMY-MAP1806HT8P-E	MMY-MAP1606HT8P-E
MMY-AP3616HT8P-E	MMY-MAP2006HT8P-E	MMY-MAP1606HT8P-E
MMY-AP3816HT8P-E	MMY-MAP2206HT8P-E	MMY-MAP1606HT8P-E

Two units connected

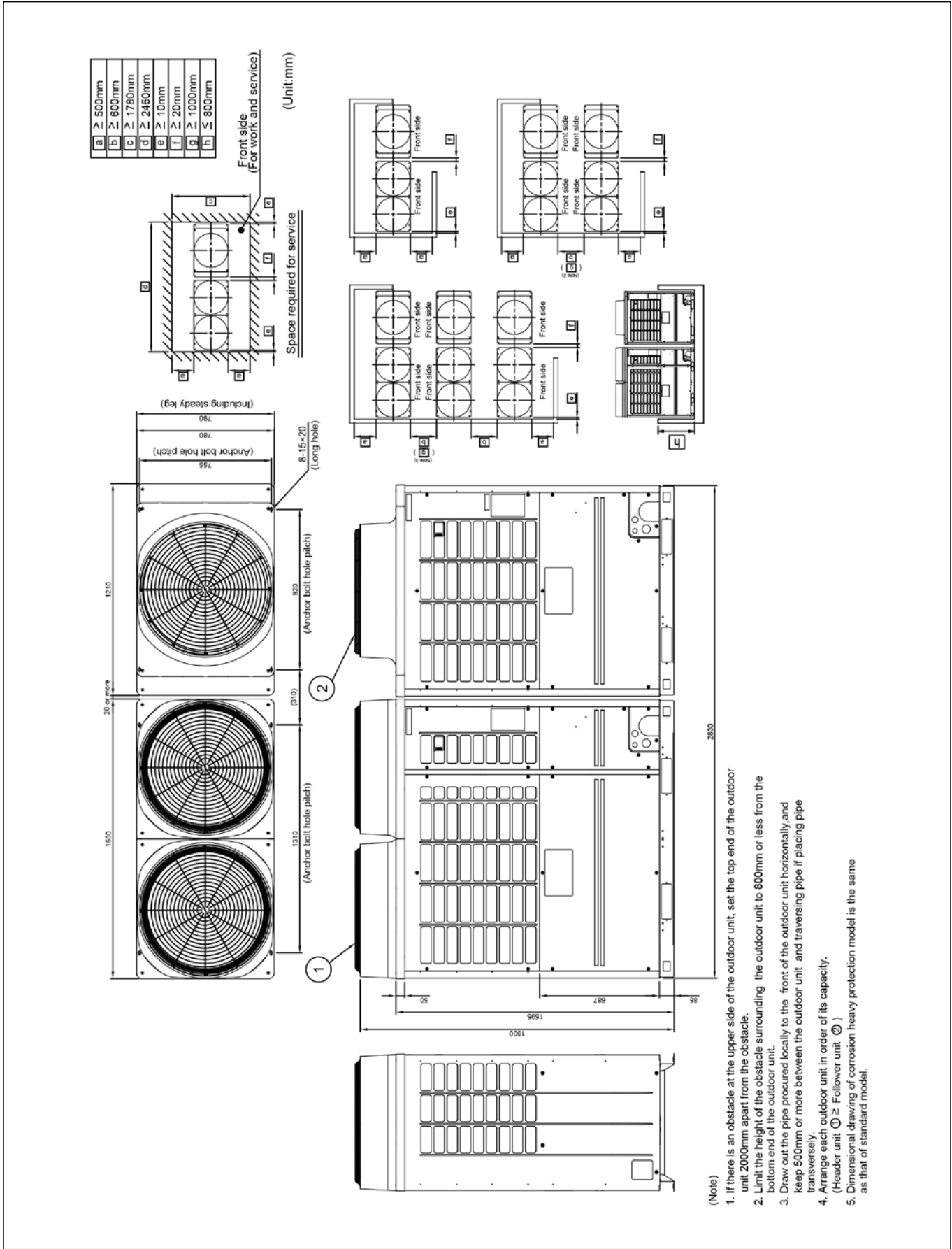



Model	Outdoor unit	
	(1) Header unit	(2) Follower unit
MMY-AP4016HT8P-E	MMY-MAP2006HT8P-E	MMY-MAP2006HT8P-E
MMY-AP4216HT8P-E	MMY-MAP2206HT8P-E	MMY-MAP2006HT8P-E
MMY-AP4416HT8P-E	MMY-MAP2206HT8P-E	MMY-MAP2206HT8P-E

Two units connected

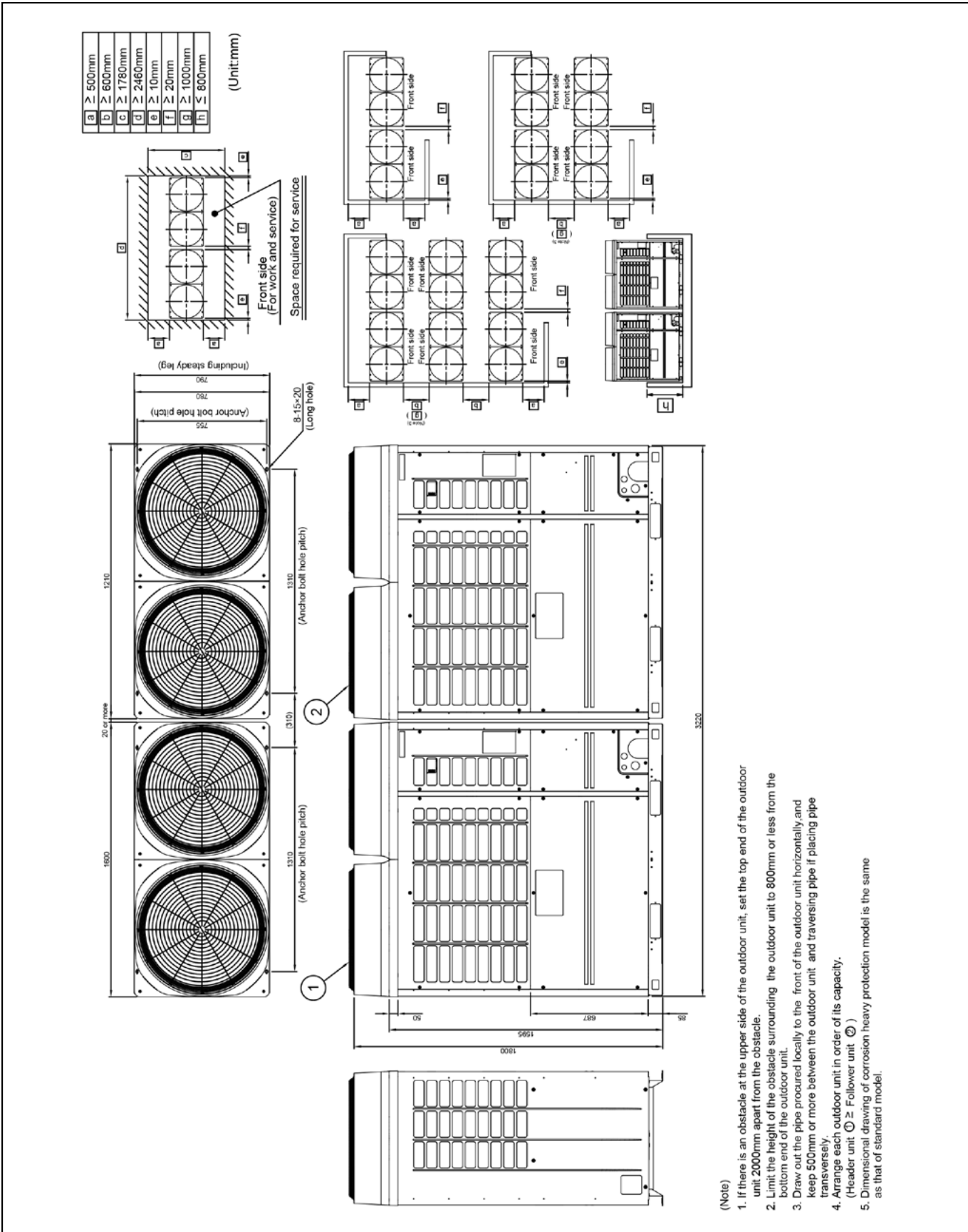



Model	Outdoor unit		
	(1) Header unit	(2) Follower unit	(3) Follower unit
MMY-AP3626HT8P-E	MMY-MAP1206HT8P-E	MMY-MAP1206HT8P-E	MMY-MAP1206HT8P-E

Three units connected

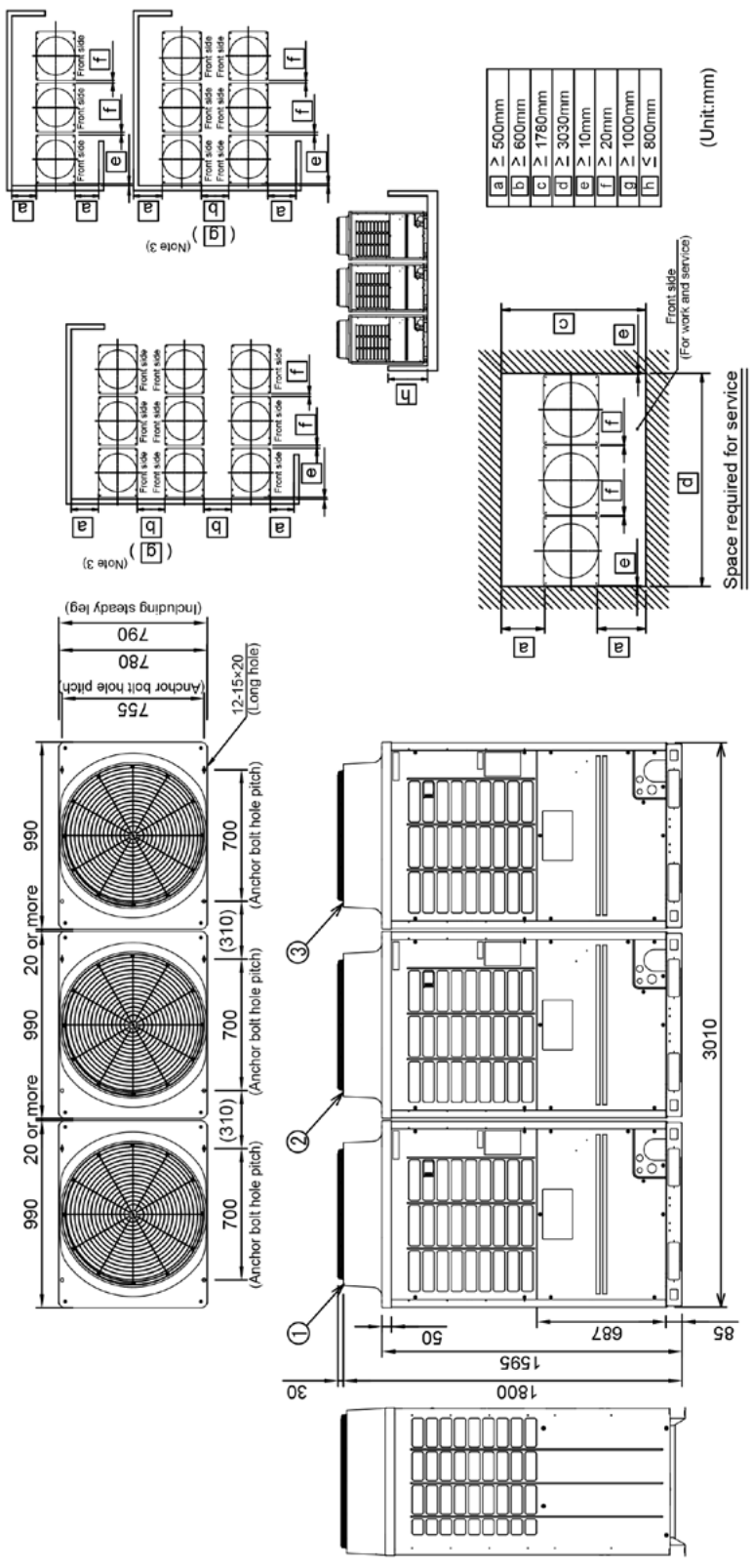

- (Note)
1. If there is an obstacle at the upper side of the outdoor unit, set the top end of the outdoor unit 2000mm apart from the obstacle.
 2. Limit the height of the obstacle surrounding the outdoor unit to 800mm or less from the bottom end of the outdoor unit.
 3. Draw out the pipe procured locally to the front of the outdoor unit horizontally, and keep 500mm or more between the outdoor unit and traversing pipe if placing pipe transversely.
 4. Arrange each outdoor unit in order of its capacity.
(Header unit $\text{⊙} \geq$ Follower unit $\text{⊙} \geq$ Follower unit ⊙)
 5. Dimensional drawing of corrosion heavy protection model is the same as that of standard model.



Model	Outdoor unit		
	(1) Header unit	(2) Follower unit	(3) Follower unit
MMY-AP3826HT8P-E	MMY-MAP1406HT8P-E	MMY-MAP1206HT8P-E	MMY-MAP1206HT8P-E

Three units connected

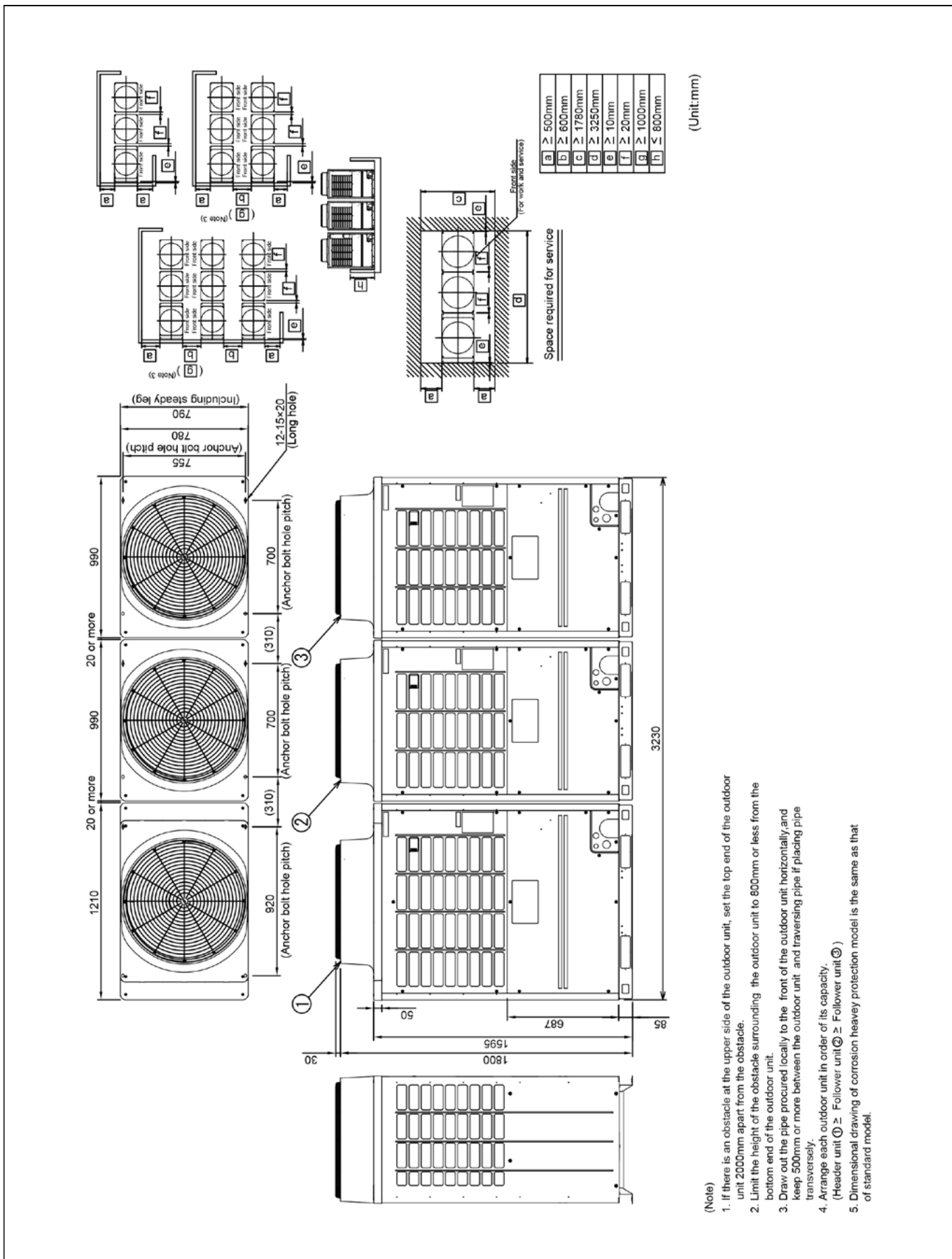

- (Note)
1. If there is an obstacle at the upper side of the outdoor unit, set the top end of the outdoor unit 2000mm apart from the obstacle.
 2. Limit the height of the obstacle surrounding the outdoor unit to 800mm or less from the bottom end of the outdoor unit.
 3. Draw out the pipe procured locally to the front of the outdoor unit horizontally, and keep 500mm or more between the outdoor unit and traversing pipe if placing pipe transversely.
 4. Arrange each outdoor unit in order of its capacity.
(Header unit ⊕ ≥ Follower unit ⊗ ≥ Follower unit ⊙)
 5. Dimensional drawing of corrosion heavy protection model is the same as that of standard model.



Model	Outdoor unit		
	(1) Header unit	(2) Follower unit	(3) Follower unit
MMY-AP4026HT8P-E	MMY-MAP1406HT8P-E	MMY-MAP1406HT8P-E	MMY-MAP1206HT8P-E

Three units connected

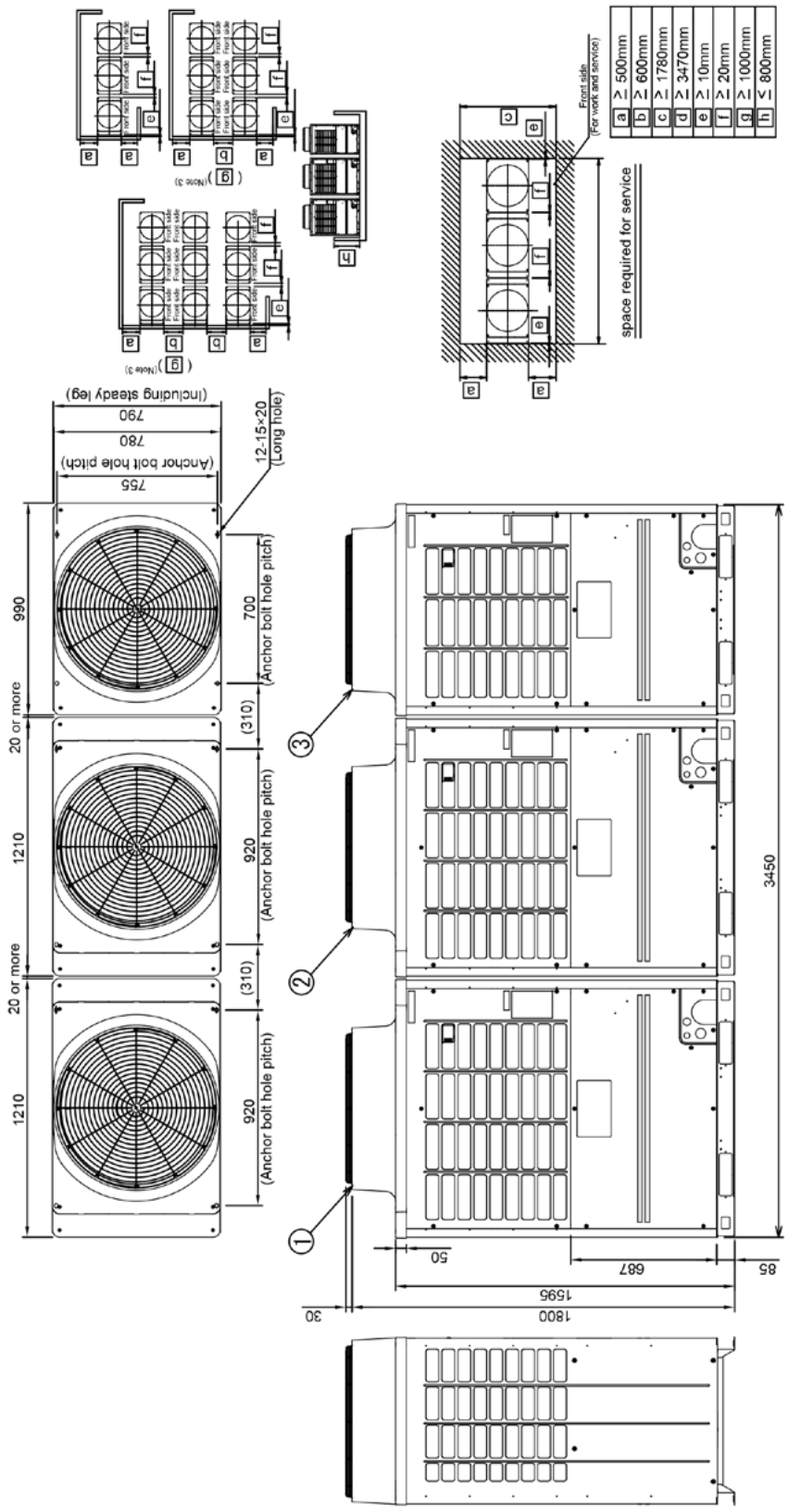

- (Note)
1. If there is an obstacle at the upper side of the outdoor unit, set the top end of the outdoor unit 2000mm apart from the obstacle.
 2. Limit the height of the obstacle surrounding the outdoor unit to 800mm or less from the bottom end of the outdoor unit.
 3. Draw out the pipe procured locally to the front of the outdoor unit horizontally, and keep 500mm or more between the outdoor unit and traversing pipe if placing pipe transversely.
 4. Arrange each outdoor unit in order of its capacity.
(Header unit ① ≥ Follower unit ② ≥ Follower unit ③)
 5. Dimensional drawing of corrosion heavy protection model is the same as that of standard model.



Model	Outdoor unit		
	(1) Header unit	(2) Follower unit	(3) Follower unit
MMY-AP4226HT8P-E	MMY-MAP1406HT8P-E	MMY-MAP1406HT8P-E	MMY-MAP1406HT8P-E
MMY-AP4426HT8P-E	MMY-MAP1606HT8P-E	MMY-MAP1406HT8P-E	MMY-MAP1406HT8P-E
MMY-AP4616HT8P-E	MMY-MAP1606HT8P-E	MMY-MAP1606HT8P-E	MMY-MAP1406HT8P-E
MMY-AP4816HT8P-E	MMY-MAP1606HT8P-E	MMY-MAP1606HT8P-E	MMY-MAP1606HT8P-E

Three units connected

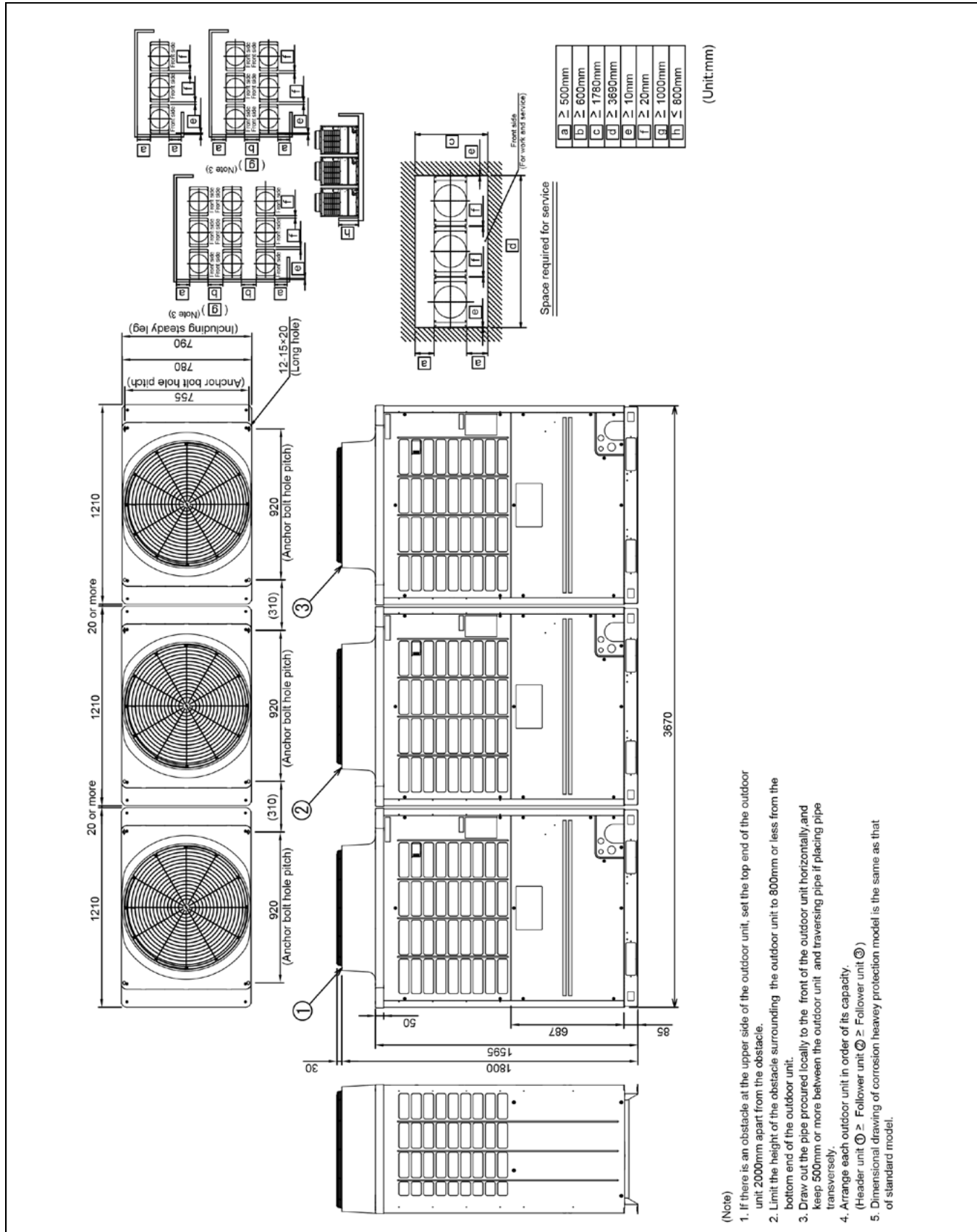



Three units connected

Model	Outdoor unit		
	(1) Header unit	(2) Follower unit	(3) Follower unit
MMY-AP5016HT8P-E	MMY-MAP1806HT8P-E	MMY-MAP1606HT8P-E	MMY-MAP1606HT8P-E
MMY-AP5216HT8P-E	MMY-MAP2006HT8P-E	MMY-MAP1606HT8P-E	MMY-MAP1606HT8P-E
MMY-AP5416HT8P-E	MMY-MAP2206HT8P-E	MMY-MAP1606HT8P-E	MMY-MAP1606HT8P-E

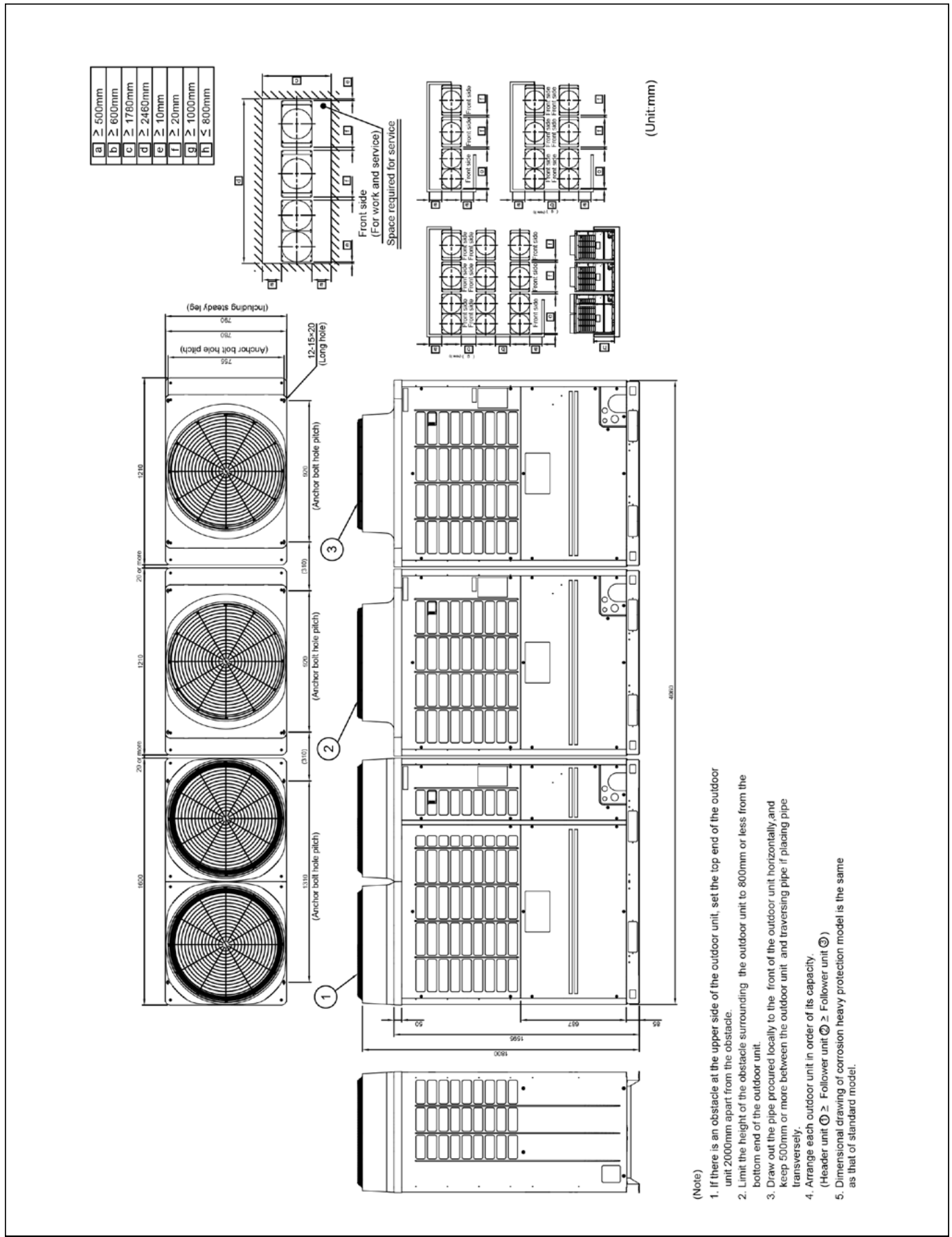



Three units connected

Model	Outdoor unit		
	(1) Header unit	(2) Follower unit	(3) Follower unit
MMY-AP5426HT8P-E	MMY-MAP2006HT8P-E	MMY-MAP2006HT8P-E	MMY-MAP1406HT8P-E
MMY-AP5616HT8P-E	MMY-MAP2006HT8P-E	MMY-MAP2006HT8P-E	MMY-MAP1606HT8P-E
MMY-AP5816HT8P-E	MMY-MAP2206HT8P-E	MMY-MAP2006HT8P-E	MMY-MAP1606HT8P-E
MMY-AP6016HT8P-E	MMY-MAP2206HT8P-E	MMY-MAP2206HT8P-E	MMY-MAP1606HT8P-E

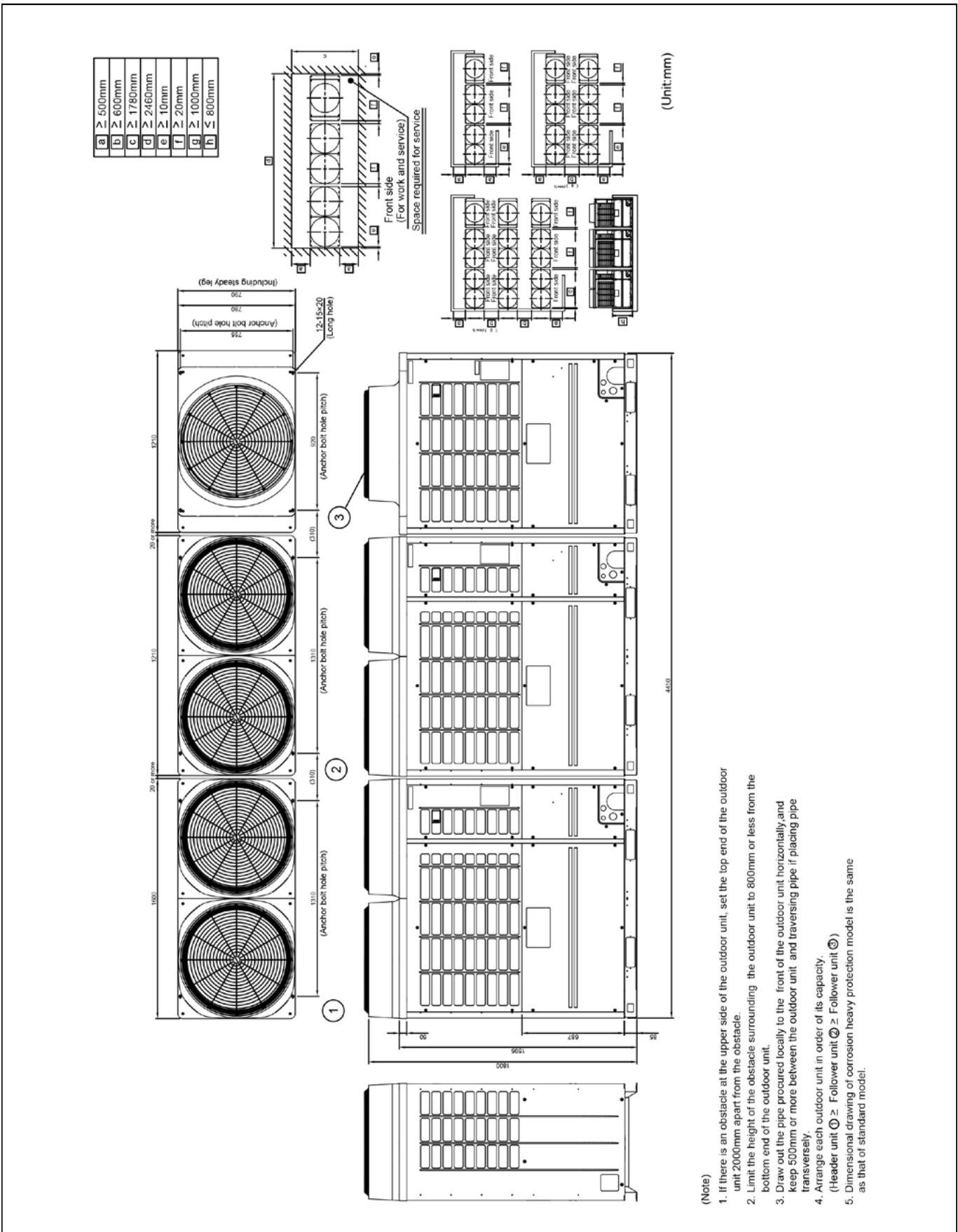



5-3. Center of gravity

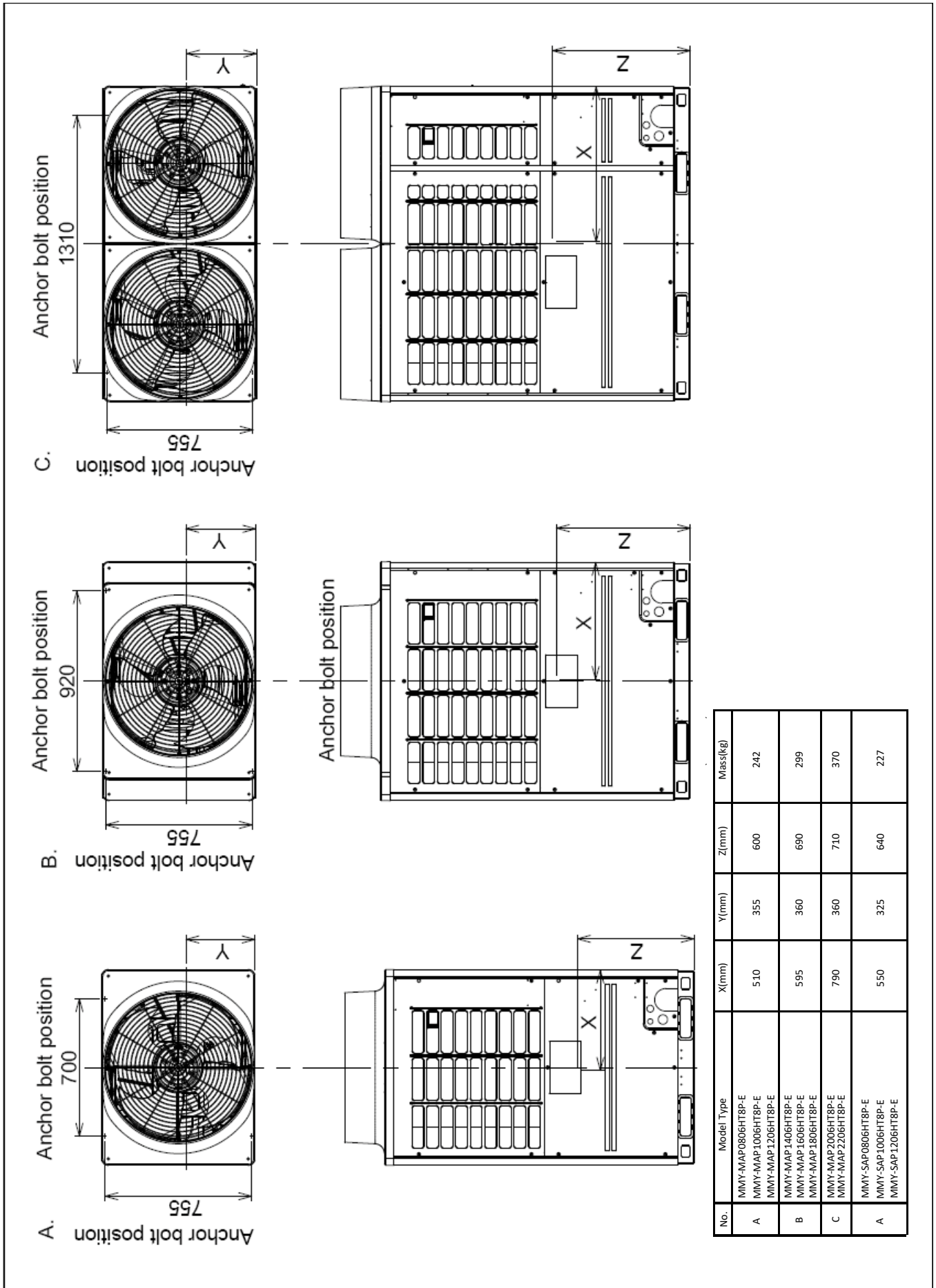



5-4. Branch header / branch joint

- Branch header
RBM-HY1043FUL, HY1083FUL, HY2043FUL, HY2083FUL

Gas side

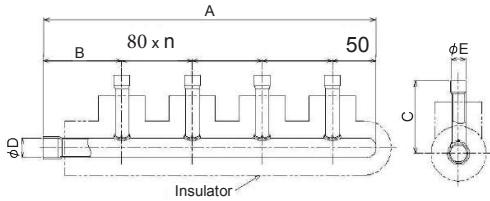

Liquid side

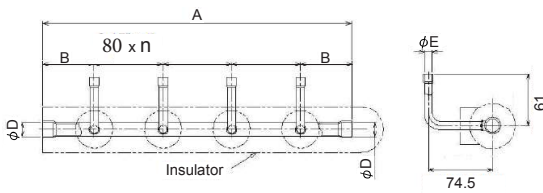

(Unit : mm)

Model		A	B	C	øD	øE	n	Accessory socket Qty
RBM-HY1043E	Gas side	380	90	83.6	22.2	15.9	3	⑥x 4, ⑨x 4, ⑭x 1, ⑱x 1, ⑳x 1
	Liquid side	360	60	-	15.9	9.5	3	①x 4, ⑥x 1, ⑨x 1
RBM-HY1083E	Gas side	700	90	83.6	22.2	15.9	7	⑥x 8, ⑨x 8, ⑭x 1, ⑱x 1, ⑳x 1
	Liquid side	680	60	-	15.9	9.5	7	①x 8, ⑥x 1, ⑨x 1
RBM-HY2043E	Gas side	385.5	95.5	89.3	31.8	15.9	3	⑥x 2, ⑨x 2, ⑳x 1, ㉑x 1
	Liquid side	360	60	-	15.9	9.5	3	①x 2 ⑤①x 1
RBM-HY2083E	Gas side	705.5	95.5	89.3	31.8	15.9	7	⑥x 7, ⑨x 7, ⑳x 1, ㉑x 1
	Liquid side	680	60	-	15.9	9.5	7	①x 7, ⑤①x 1

- Y-shape branch joint
RBM-BY55E, BY105E, BY205E, BY305E

Gas side

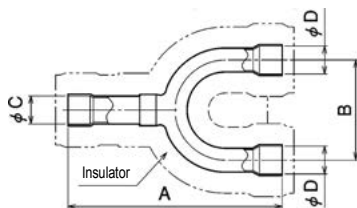

Liquid side

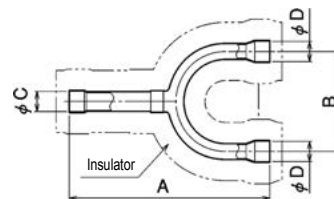

(Unit : mm)

RBM-		A	B	øC	øD	Accessory socket Qty
BY55E	Gas side	160	80	15.9	15.9	⑨x 1, ⑤①x 2, ⑨①x 2
	Liquid side	130	70	9.5	9.5	①x 2te
BY105E	Gas side	170	80	22.2	22.2	⑭x 2, ⑳x 2, ⑨①x 1
	Liquid side	160	80	15.9	15.9	⑨x 1, ⑨①x 1, ⑨②x 1
BY205E	Gas side	200	80	31.8	28.6	⑱x 1, ⑳x 1, ④③x 2, ⑤③x 1, ⑤④x 1, ⑨①x 1
	Liquid side	160	80	15.9	15.9	⑨x 1, ⑤①x 2, ⑨②x 1
BY305E	Gas side	220	80	38.1	38.1	④③x 1, ⑥①x 3, ⑥②x 2, ⑦①x 2, ⑦⑤x 1, ⑨①x 1
	Liquid side	170	80	22.2	22.2	⑨②x 1, ⑨③x 3, ⑦⑦x 2



• Branching joint for connection of outdoor units (Set of three kinds of joint)
RBM-BT14E

Gas side

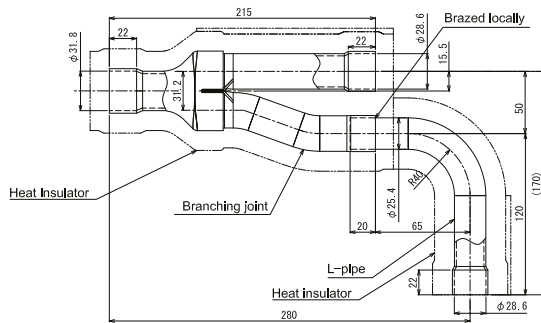

Liquid side

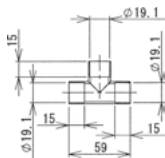

Balance pipe

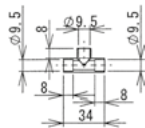

RBM-BT14E	
Accessory socket Qty	
Gas side	②7 x 1, ④3 x 2, ⑤9 x 1
Liquid side	⑩ x 3, ⑬ x 1

RBM-BT24E

Gas side

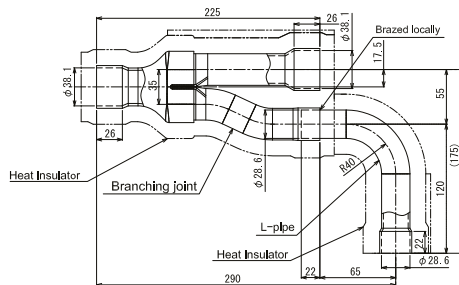

Liquid side

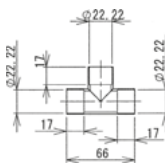

Balance pipe

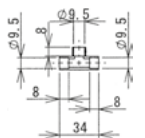

RBM-BT24E	
Accessory socket Qty	
Gas side	④3 x 1, ⑥1 x 2, ⑥2 x 2, ⑦1 x 1, ⑦3 x 1
Liquid side	⑭ x 3, ⑱ x 3, ⑥5 x 1, ⑦0 x 1

(Unit : mm)



• Accessory socket

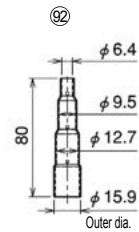
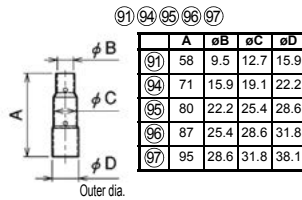
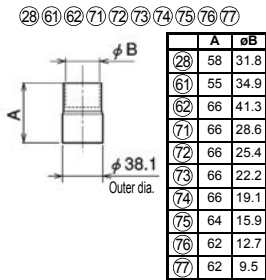
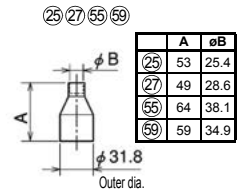
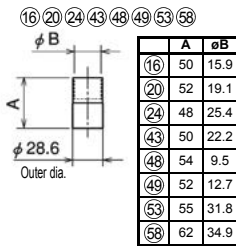
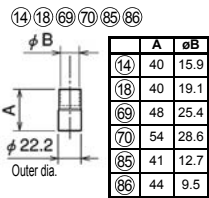
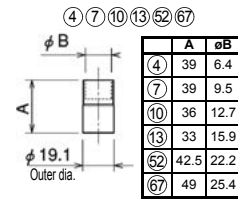
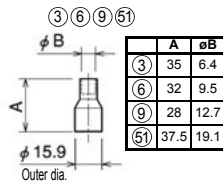
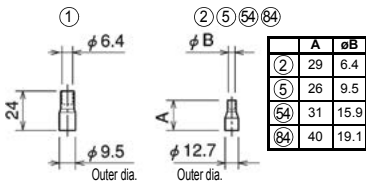

Closure tube

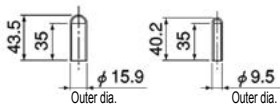

(Unit : mm)



5.5 Refrigerant cycle diagram

MMY-MAP0806HT8P-E, MMY-MAP1006HT8P-E, MMY-MAP1204HTP-E

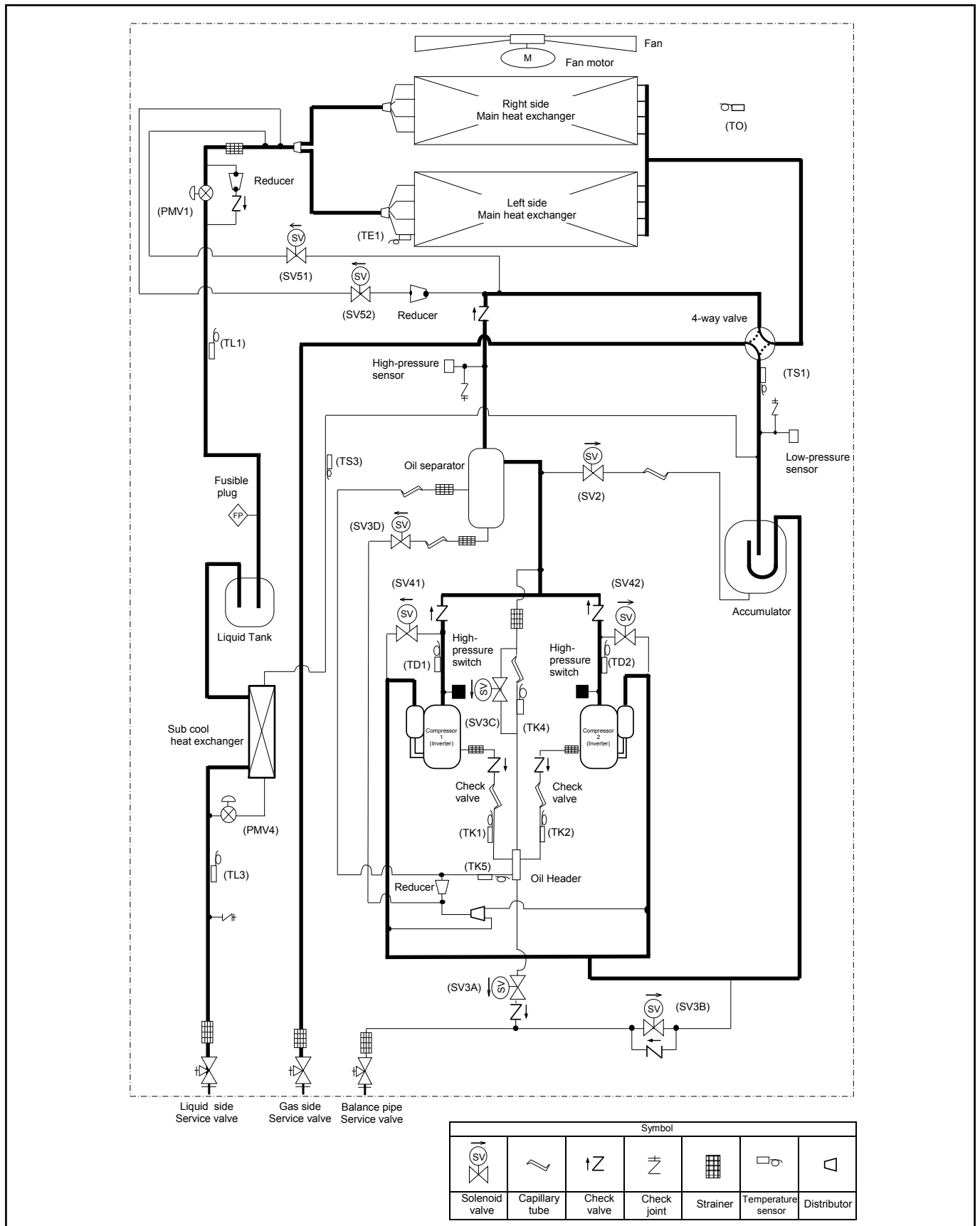

MMY-MAP1406HT8P-E, MMY-MAP1606HTP-E

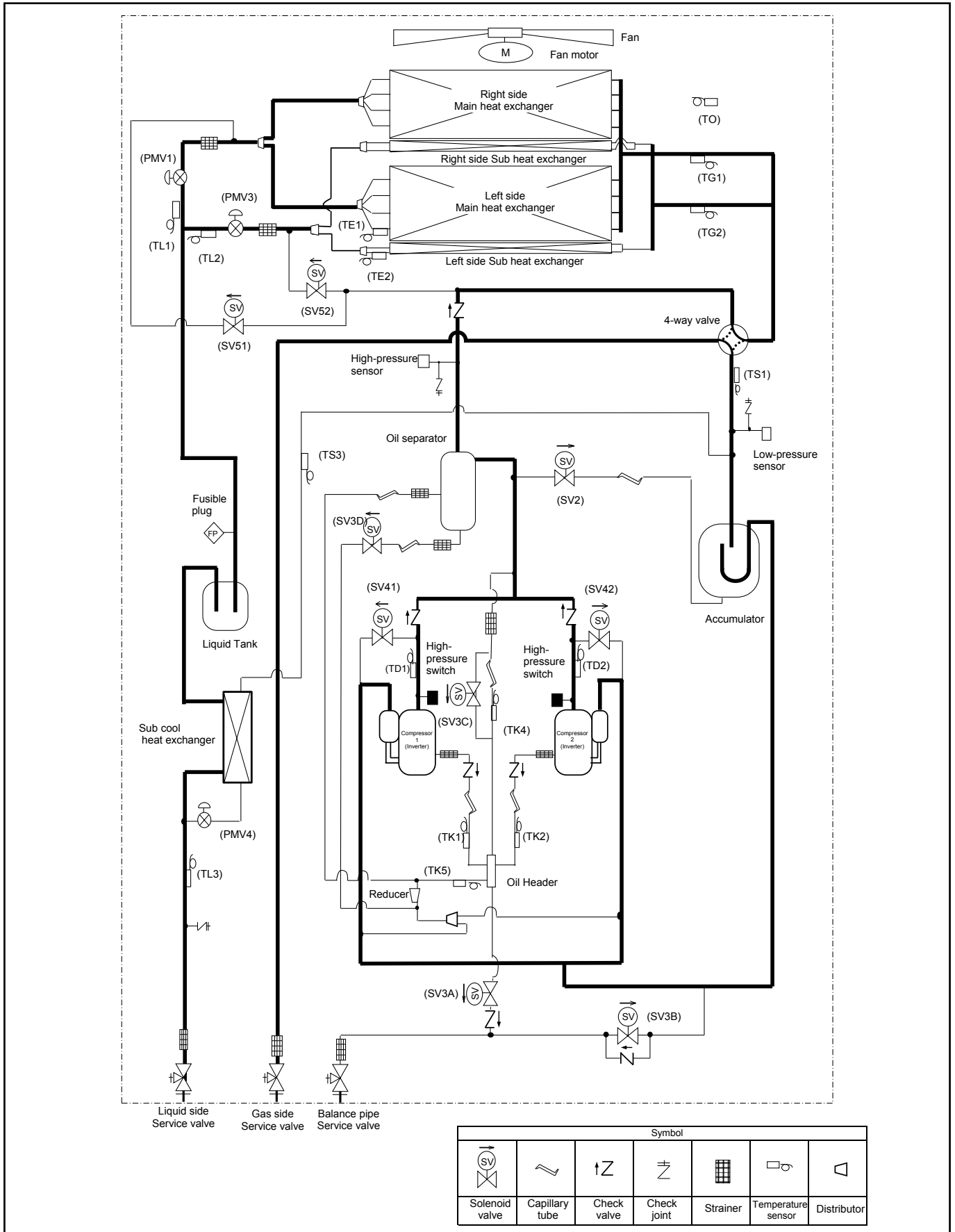

MMY-MAP1806HT8P-E, MMY-MAP2006HT8P-E, MMY-MAP2204HT8P-E

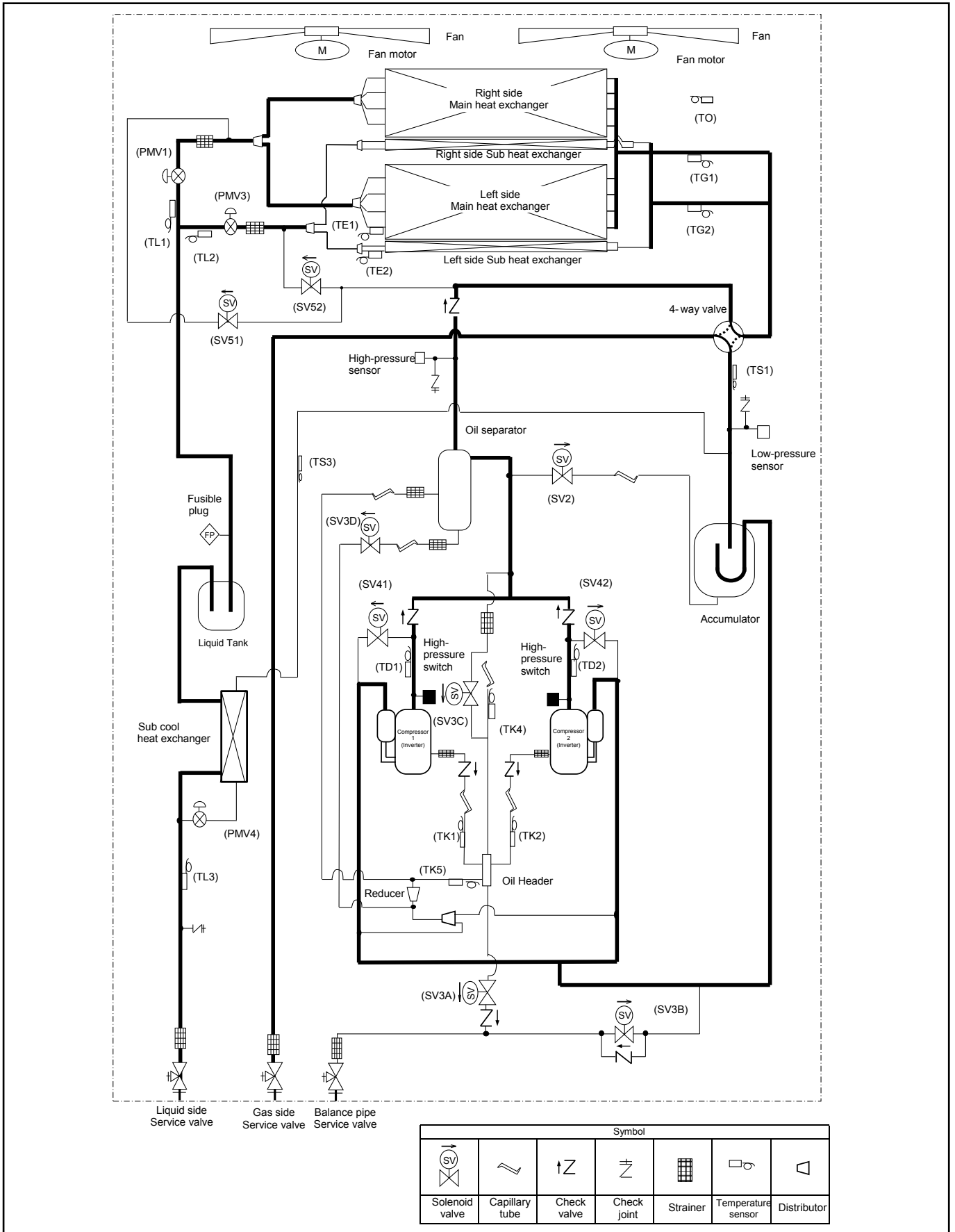

MMY-SAP0806HT8P-E, MMY-SAP1006HT8P-E, MMY-SAP1206HT8P-E

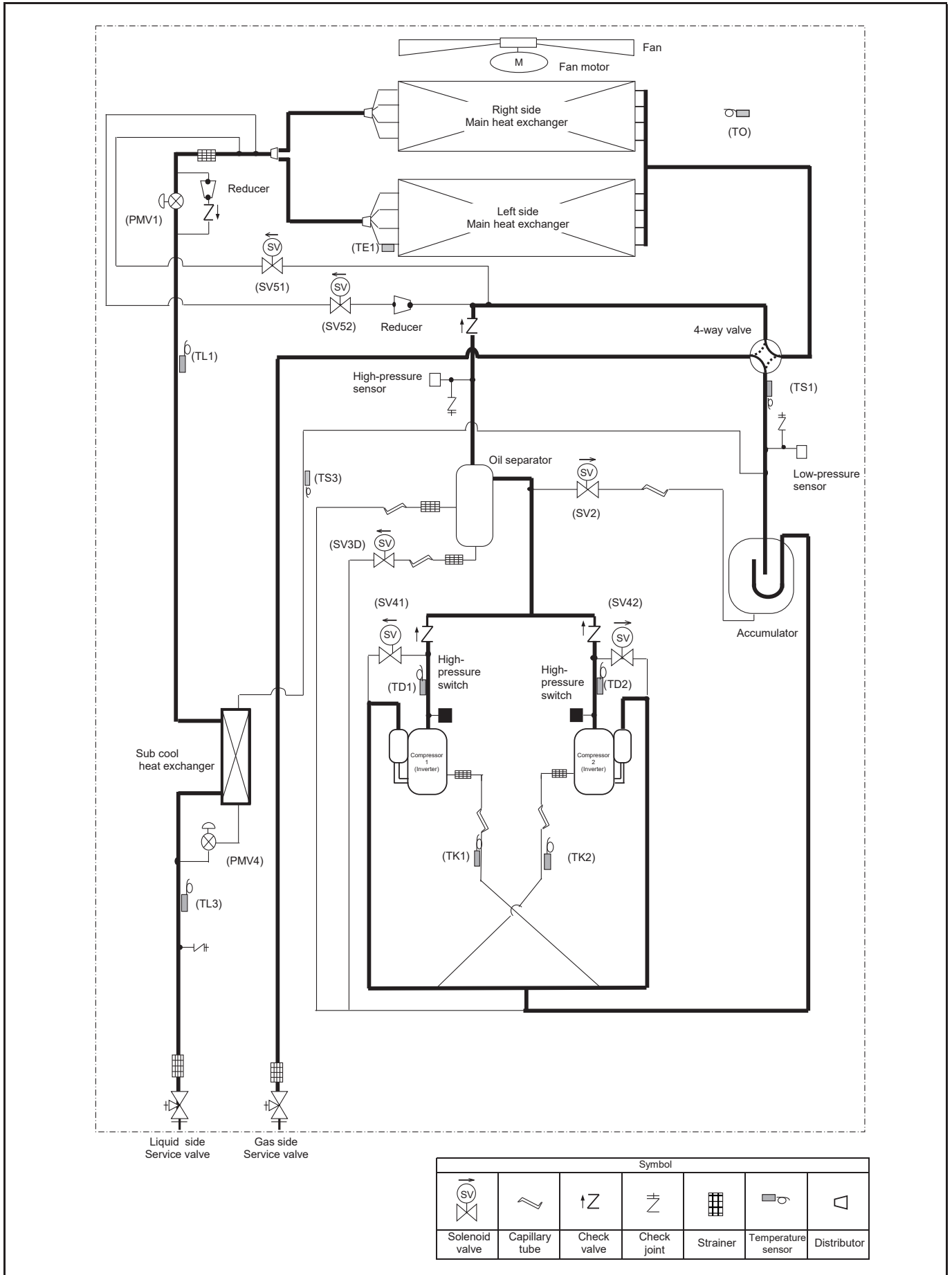



5-6. Wiring diagram

MMY-MAP0806HT8P-E, MMY-MAP1006HT8P-E, MMY-MAP1206HT8P-E

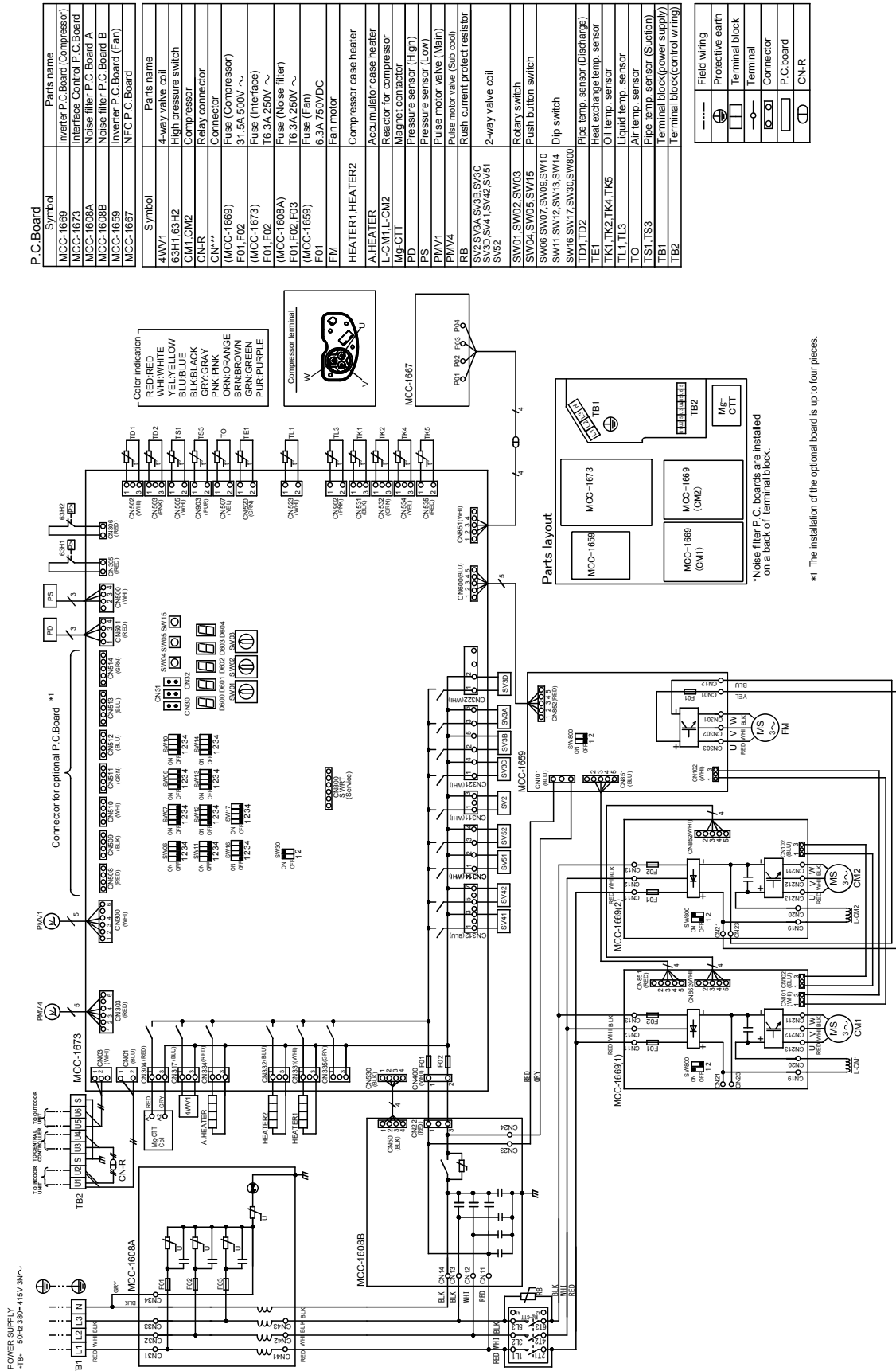

Symbol	Parts name
MCC-1669	Inverter P.C. Board (Compressor)
MCC-1673	Interface Control P.C. Board
MCC-1608A	Noise filter P.C. Board A
MCC-1608B	Noise filter P.C. Board B
MCC-1659	Inverter P.C. Board (Fan)
MCC-1667	NFC P.C. Board

Symbol	Parts name
4WV1	4-way valve coil
63H1, 63H2	High pressure switch
CM1, CM2	Compressor
CN-R	Relay connector
CN**	Connector
F01, F02	Fuse (Compressor)
(MCC-1669)	31.5A 500V ~
(MCC-1673)	T6.3A 250V ~
(MCC-1608A)	T6.3A 250V ~
F01, F02, F03	Fuse (Fan)
(MCC-1659)	6.3A 750VDC
FM	Fan motor

Symbol	Parts name
HEATER1, HEATER2	Compressor case heater
A, HEATER	Accumulator case heater
L, CM1, L, CM2	Reactor for compressor
MS, CTT	Magnet for compressor
PS	Pressure sensor (High)
PS	Pressure sensor (Low)
PMV1	Pulse motor valve (Main)
PMV4	Pulse motor valve (Sub-cool)
RB	Rush current protect resistor
SV2, SV3A, SV3B, SV3C	2-way valve coil
SV2, SV41, SV42, SV43	2-way valve coil
SV52	2-way valve coil

Symbol	Parts name
SW01, SW02, SW03	Rotary switch
SW04, SW05, SW15	Push button switch
SW06, SW07, SW09, SW10	Dip switch
SW11, SW12, SW13, SW14	Dip switch
SW16, SW17, SW20, SW800	Dip switch
TD1, TD2	Pipe temp. sensor (Discharge)
TE1	Heat exchange temp. sensor
TK1, TK2, TK4, TK5	Oil temp. sensor
TL1, TL3	Liquid temp. sensor
TO	Air temp. sensor
TS1, TS3	Pipe temp. sensor (Suction)
TB1	Terminal block (power supply)
TB2	Terminal block (control wiring)

Symbol	Parts name
Field wiring	Field wiring
Protective earth	Protective earth
Terminal block	Terminal block
Terminal	Terminal
Connector	Connector
P.C. board	P.C. board
CN-R	CN-R

Color indication
 RED: RED
 WHI: WHITE
 BLU: BLUE
 BLK: BLACK
 GRY: GRAY
 PNK: PINK
 ORN: ORANGE
 BRN: BROWN
 GRN: GREEN
 PUR: PURPLE

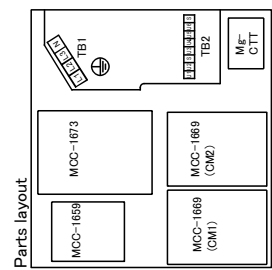
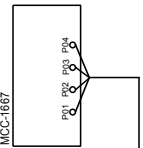
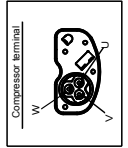

*Noise filter P.C. boards are installed on a back of terminal block.

*1 The installation of the optional board is up to four pieces.

POWER SUPPLY
 18V, 50Hz, 300-415V, 3N~



Symbol	Parts name
MCC-1669	Inverter P.C. Board (Compressor)
MCC-1673	Interface Control P.C. Board
MCC-1608A	Noise filter P.C. Board A
MCC-1608B	Noise filter P.C. Board B
MCC-1659	Inverter P.C. Board (Fan)
MCC-1667	NFC P.C. Board
4WV1	4-way valve coil
63H1.63H2	High pressure switch
CM1,CM2	Compressor
CNR	Relay connector
CN***	Connector
(MCC-1669)	Fuse (Compressor)
F01.F02	31.5A 500V ~
(MCC-1673)	Fuse (Interface)
F01.F02	TB-3A 250V ~
(MCC-1608A)	Fuse (Noise filter)
F01.F02.F03	TB-3A 250V ~
(MCC-1659)	Fuse (Fan)
F01	6.3A 750VDC
FM	Fan motor
HEATER1,HEATER2	Compressor case heater
A,HEATER	Accumulator case heater
L-CM1,L-CM2	Reactor for compressor
Mp-CIT	Magnet contactor
PD	Pressure sensor (High)
PS	Pressure sensor (Low)
PMV1	Pulse motor valve (Main)
PMV3	Pulse motor valve (Sub)
PMW4	Pulse motor valve (Sub cool)
RB	Rush current protect resistor
SV2,SV3A,SV3B,SV3C,SV3D,SV41,SV42,SV51,SV52	2-way valve coil
SW01,SW02,SW03	Rotary switch
SW06,SW07,SW09,SW10,SW11,SW12,SW13,SW14,SW16,SW17,SW30,SW600	Push button switch
TD1,TD2	Dip switch
TE1,TE2	Pipe temp. sensor (Discharge)
TK1,TK2,TK4,TK5	Heat exchange temp. sensor
TL1,TL2,TL3	Oil temp. sensor
TO	Liquid temp. sensor
TS1,TS3	Air temp. sensor
TG1,TG2	Pipe temp. sensor (Suction)
TB1	Gas temp. sensor
TB2	Terminal block(power supply)
TB3	Terminal block(control wiring)
---	Terminal block(internal wiring connector)

Symbol	Field wiring
⊕	Protective earth
□	Terminal block
○	Terminal
⊗	Connector
□	P.C. board
○	CN-R

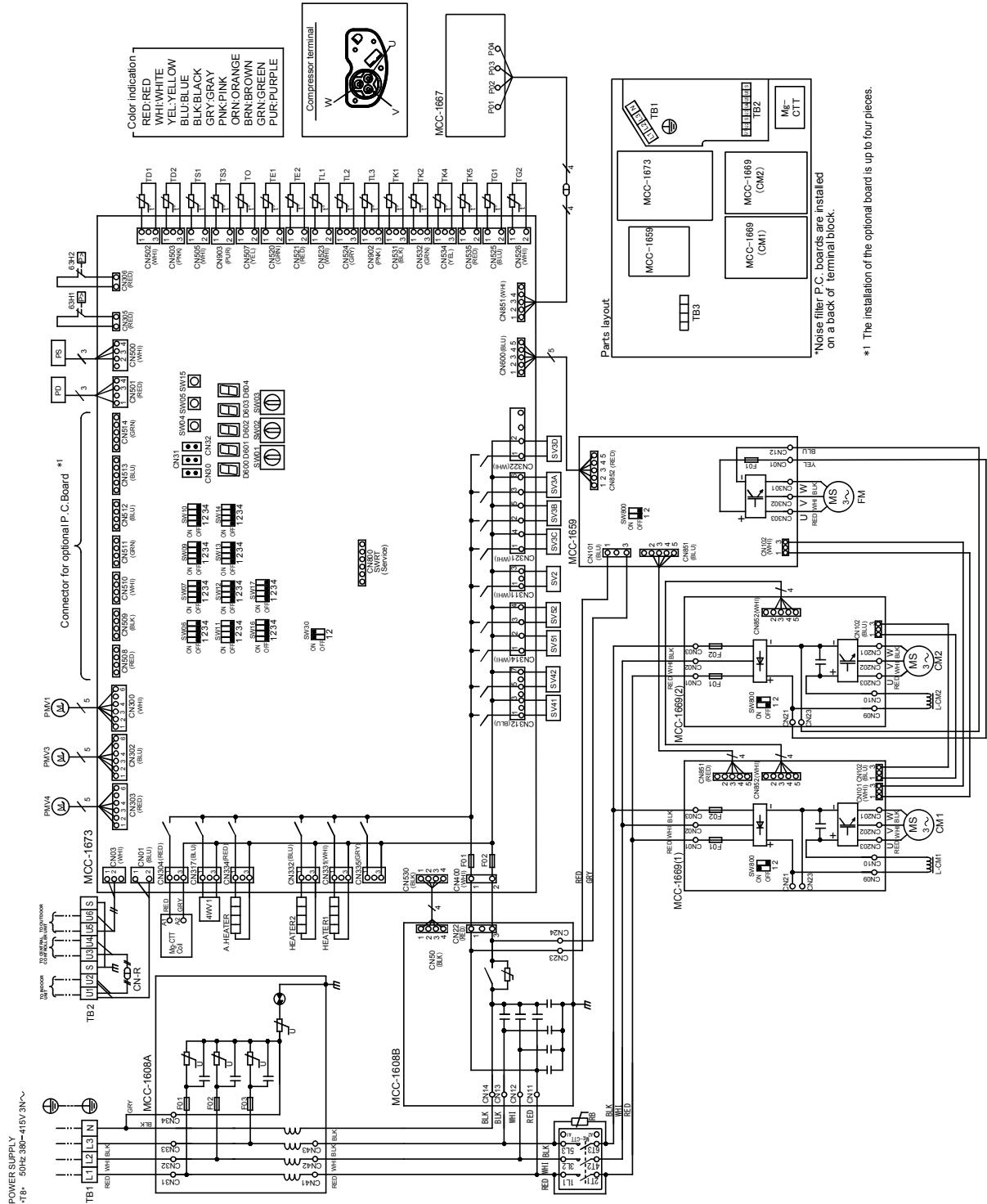



P.C. Board	Symbol	Parts name
MCC-1660		Inverter P.C. Board (Compressor)
MCC-1673		Interface Control P.C. Board
MCC-1608A		Noise filter P.C. Board A
MCC-1608B		Noise filter P.C. Board B
MCC-1659		Inverter P.C. Board (Fan)
MCC-1667		NFC P.C. Board

Symbol	Parts name
4WV1	4-way valve coil
63H1.63HZ	High pressure switch
CM1,CM2	Compressor
CNR	Relay connector
CNR**	Connector
(MCC-1660)	Fuse (Compressor)
F01, F02	40A 500V ~
(MCC-1673)	Fuse (Interface)
F01, F02	T6-3A 250V ~
(MCC-1608A)	Fuse (Noise filter)
F01, F02, F03	T6-3A 250V ~
(MCC-1659)	Fuse (Fan)
F01	6.3A 750VDC
FM1, FM2	Fan motor
HEATER1, HEATER2	Compressor case heater
A, HEATER	Accumulator case heater
L-CM1, L-CM2	Reactor for compressor
Mp-CTT1, Mp-CTT2	Magnet contactor
PD	Pressure sensor (High)
PS	Pressure sensor (Low)
PMV1	Pulse motor valve (Main)
PMV3	Pulse motor valve (Sub)
PMV4	Pulse motor valve (Sub cool)
RB	Rush current protect resistor
SV2, SV3A, SV3B, SV3C	2-way valve coil
SV3D, SV41, SV42, SV43	
SV52	
SW01, SW02, SW03	Rotary switch
SW04, SW05, SW15	Push button switch
SW06, SW07, SW08, SW10	
SW11, SW12, SW13, SW14	Dip switch
SW16, SW17, SW30, SW800	
TD1, TD2	Pipe temp. sensor (Discharge)
TE1, TE2	Heat exchange temp. sensor
TK1, TK2, TK4, TK5	Liquid temp. sensor
TL1, TL2, TL3	Air temp. sensor
TO	Pipe temp. sensor (Suction)
TS1, TS3	Pipe temp. sensor
TG1, TG2	Gas temp. sensor
TB1	Terminal block (power supply)
TB2	Terminal block (control wiring)
TB3	Terminal block (internal wiring connection)

Field wiring
Protective earth
Terminal block
Terminal
Connector
P.C. board
CNR

Color indication
 WHI-WHITE
 YEL-YELLOW
 BLU-BLUE
 BK-BLACK
 GRK-GRAY
 PRN-PINK
 BRN-BROWN
 GRN-GREEN
 PUR-PURPLE

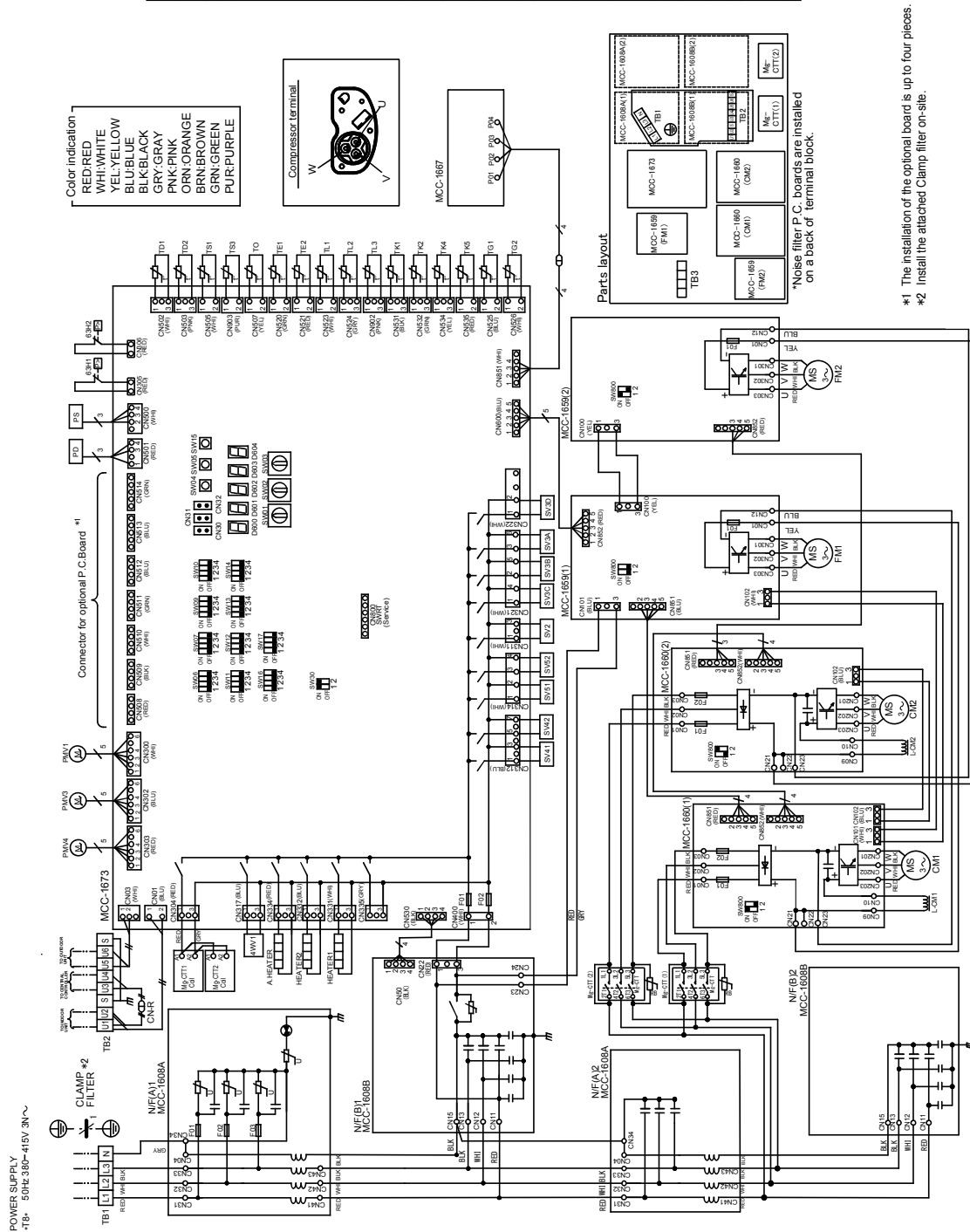
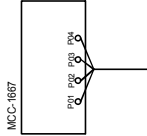
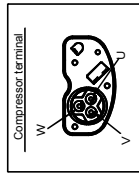

*Noise filter P.C. boards are installed on a back of terminal block.
 #1 The installation of the optional board is up to four pieces.
 #2 Install the attached Clamp filter on-site.



Symbol	Parts name
MCC-1669	Inverter P.C. Board (Compressor)
MCC-1673	Interface Control P.C. Board
MCC-1608A	Noise filter P.C. Board A
MCC-1608B	Noise filter P.C. Board B
MCC-1659	Inverter P.C. Board (Fan)

Symbol	Parts name
4WV1	4-way valve coil
6SH1, 6SH2	High pressure switch
CM1, CM2	Compressor
CN-R	Relay connector
CN-4**	Connector
(MCC-1669)	Fuse (Compressor)
F01, F02	31.5A 500VAC
(MCC-1673)	Fuse (Interface)
F01, F02	T6.3A 250VAC
(MCC-1608A)	Fuse (Noise filter)
F01, F02, F03	T6.3A 250VAC
(MCC-1659)	Fuse (Fan)
F01	6.3A 750VDC
FM	Fan motor
HEATER1, HEATER2	Compressor case heater
A-HEATER	Accumulator case heater
L-CM1, L-CM2	Resistor for compressor
Mg-C1T	Magnet conductor
PD	Pressure sensor (High)
PS	Pressure sensor (Low)
PMV1	Pulse motor valve (Main)
PMV4	Pulse motor valve (Sub cool)
RB	Rush current protect resistor
SV2, SV3D, SV41, SV42	2-way valve coil
SV51, SV52	Relay switch
SW01, SW02, SW03	Relay switch
SW04, SW05, SW15	Push button switch
SW06, SW07, SW09, SW10	Push button switch
SW11, SW12, SW13, SW14	Diode
SW16, SW17, SW30, SW800	Diode
TD1, TD2	Pipe temp. sensor (Discharge)
TE1	Heat exchange temp. sensor
TK1, TK2	Oil temp. sensor
TL1, TL3	Liquid temp. sensor
TO	Air temp. sensor
TS1, TS3	Pipe temp. sensor (Suction)
TB1	Terminal block (power supply)
TB2	Terminal block (control wiring)

Symbol	Field wiring
⊕	Protective earth
□	Terminal block
○	Terminal
⊗	Connector
⊞	P. C. Board
⊞	CN-R

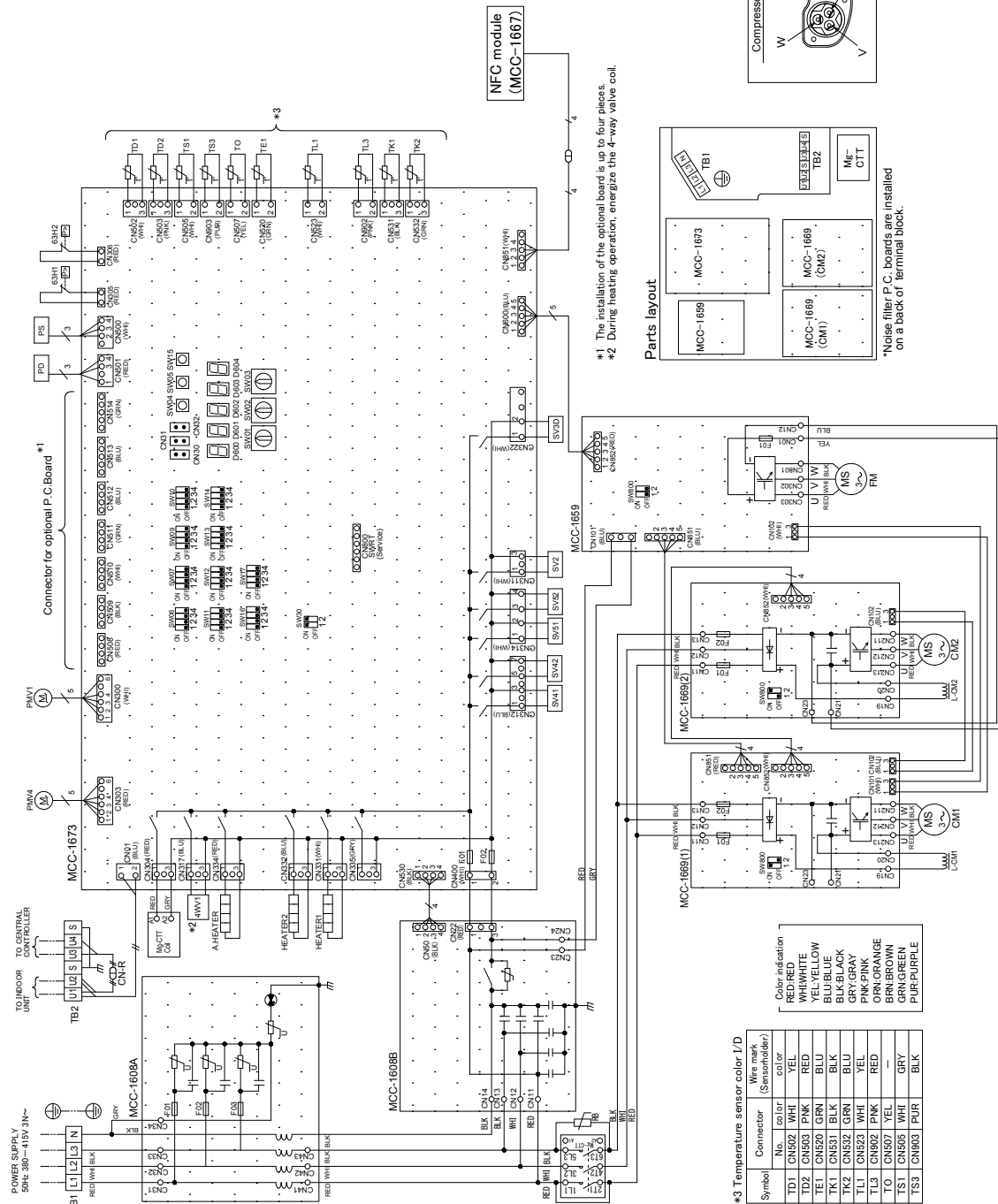
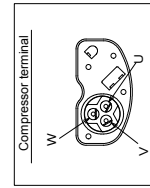

*1 The installation of the optional board is up to four pieces.
*2 During heating operation, energize the 4-way valve coil.

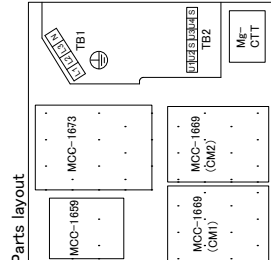

*Noise filter P.C. boards are installed on a back of terminal block.

Symbol	Wire mark (Sensor side)	Wire mark (Sense side)	Color indication
TD1	CN502	WHI	YEL
TD2	CN503	PNK	RED
TE1	CN520	GRN	BLU
TK1	CN531	BLK	BLK
TK2	CN532	GRN	YLU
TL3	CN505	PNK	RED
TO	CN507	YEL	RED
TS1	CN505	WHI	GRY
TS3	CN503	PNK	BLK

5-7. Connecting diagram

Single unit connected

Model : MMY-MAP***6HT8P-E
MMY-SAP***6HT8P-E

①	Outdoor unit (Header unit)
②	—
③	Indoor unit
④	Remote controller
⑤	Central remote controller (option)
⑥	Main switch (Fuse)
⑦	Circuit breaker (Earth leakage breaker)
⑧	Pull box

W1 : Control wiring between indoor and outdoor units
W2 : Control wiring between indoor units

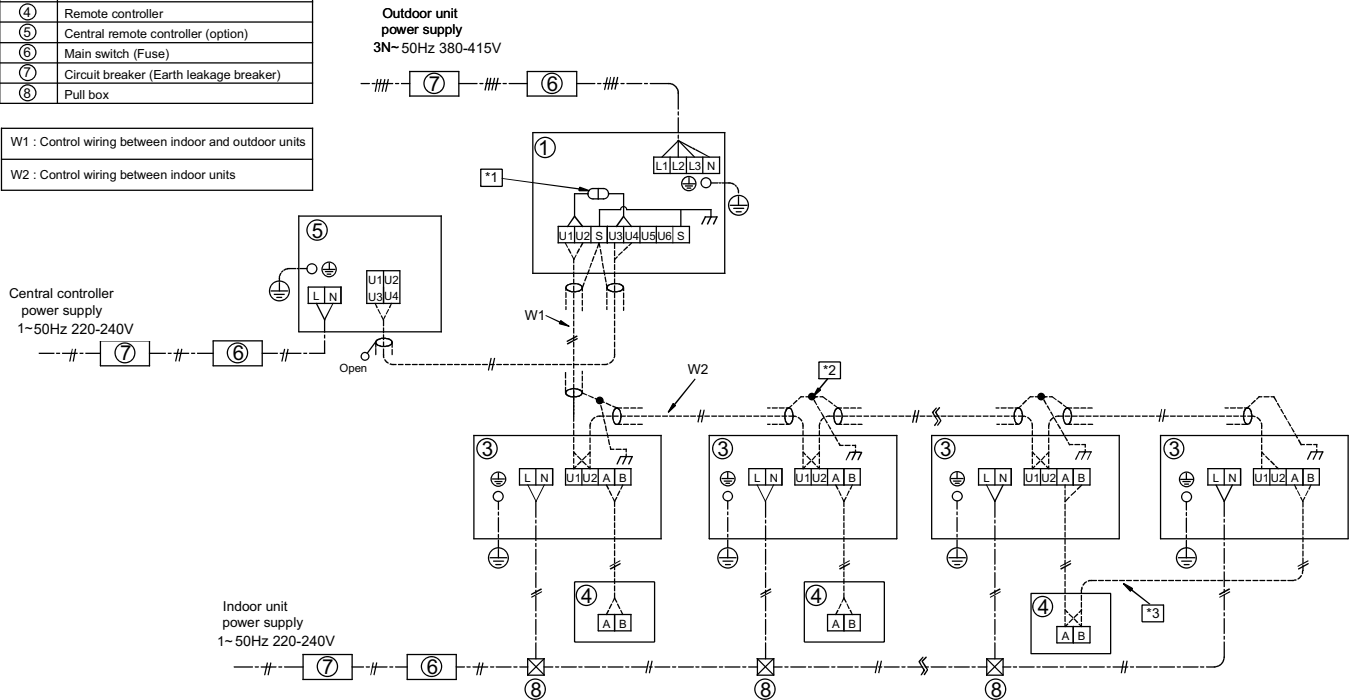

(Note)

- When perform a central control, connect the relay connector between [U1,U2] and [U3,U4] terminal of the header unit. (At shipment from factory : No connection)
- Connect the closed end terminal of shield wire.
(Connected to all connecting sections in each unit)
- Group control.
- Select the power supply wiring and fuse of outdoor/indoor units according to each model's specification.
Perform wiring of power supply complying with the rules and regulations of the local electric company.
- For the control wires connecting indoor units, outdoor units, and between indoor and outdoor units, use 2-core and non-polarity shield wires.
- As for details, see the wiring diagram of indoor/outdoor unit.
- Diagram of corrosion heavy protection model is the same as that of standard model.
- MMY-SAP***6HT8P-E models do not have U5 and U6 terminals.



Two units connected
Model : MMY-AP*6HT8P-E**

①	Outdoor unit (Header unit)
②	Outdoor unit (Follower unit)
③	Indoor unit
④	Remote controller
⑤	Central remote controller (option)
⑥	Main switch (Fuse)
⑦	Circuit breaker (Earth leakage breaker)
⑧	Pull box

W1 : Control wiring between indoor and outdoor units
W2 : Control wiring between indoor units
W3 : Control wiring between outdoor units

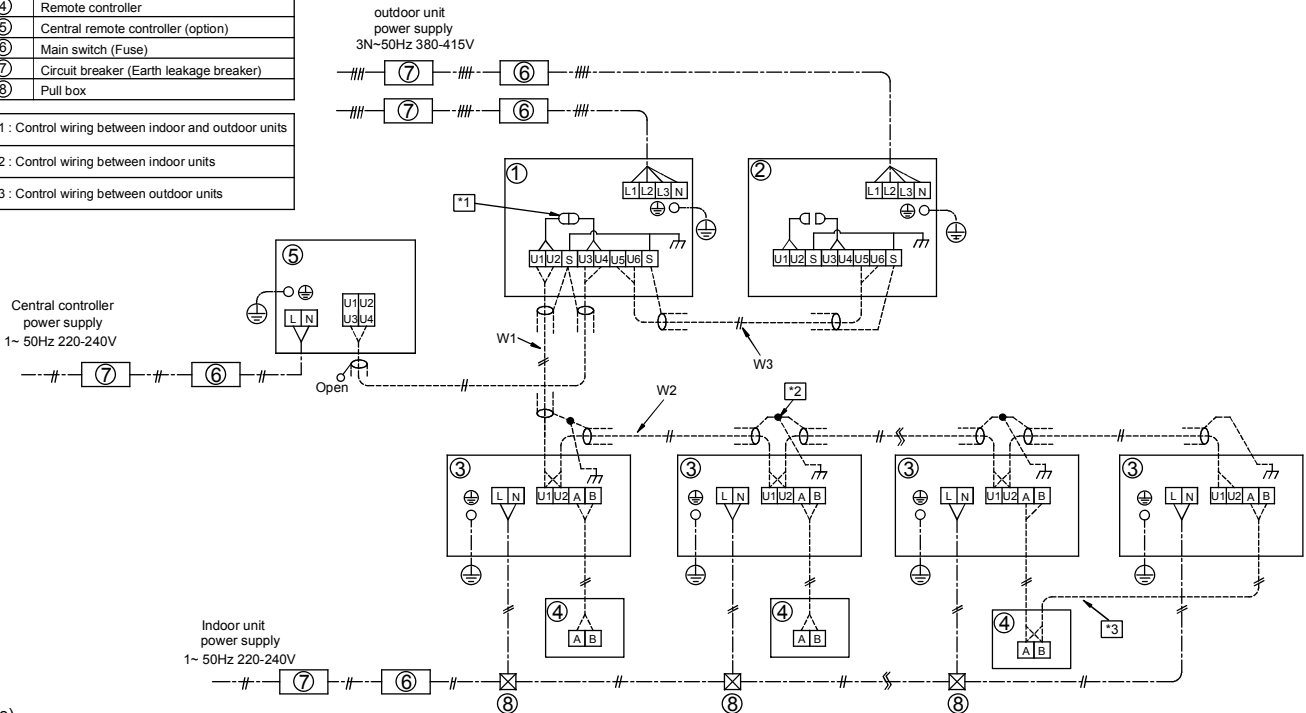

(Note)

1. When perform a central control, connect the relay connector between [U1,U2] and [U3,U4] terminal of the header unit. (At shipment from factory : No connection)
2. Connect the closed end terminal of shield wire. (Connected to all connecting sections in each unit)
3. Group control.
4. Select the power supply wiring and fuse of outdoor/indoor units according to each model's specification. Perform wiring of power supply complying with the rules and regulations of the local electric company.
5. For the control wires connecting indoor units, outdoor units, and between indoor and outdoor units, use 2-core and non-polarity shield wires.
6. As for details, see the wiring diagram of indoor/outdoor unit.
7. Diagram of corrosion heavy protection model is the same as that of standard model.

Three units connected

Model : MMY-AP***6HT8P-E

①	Outdoor unit (Header unit)
②	Outdoor unit (Follower unit)
③	Indoor unit
④	Remote controller
⑤	Central remote controller (option)
⑥	Main switch (Fuse)
⑦	Circuit breaker (Earth leakage breaker)
⑧	Pull box

W1 : Control wiring between indoor and outdoor units

W2 : Control wiring between indoor units

W3 : Control wiring between outdoor units

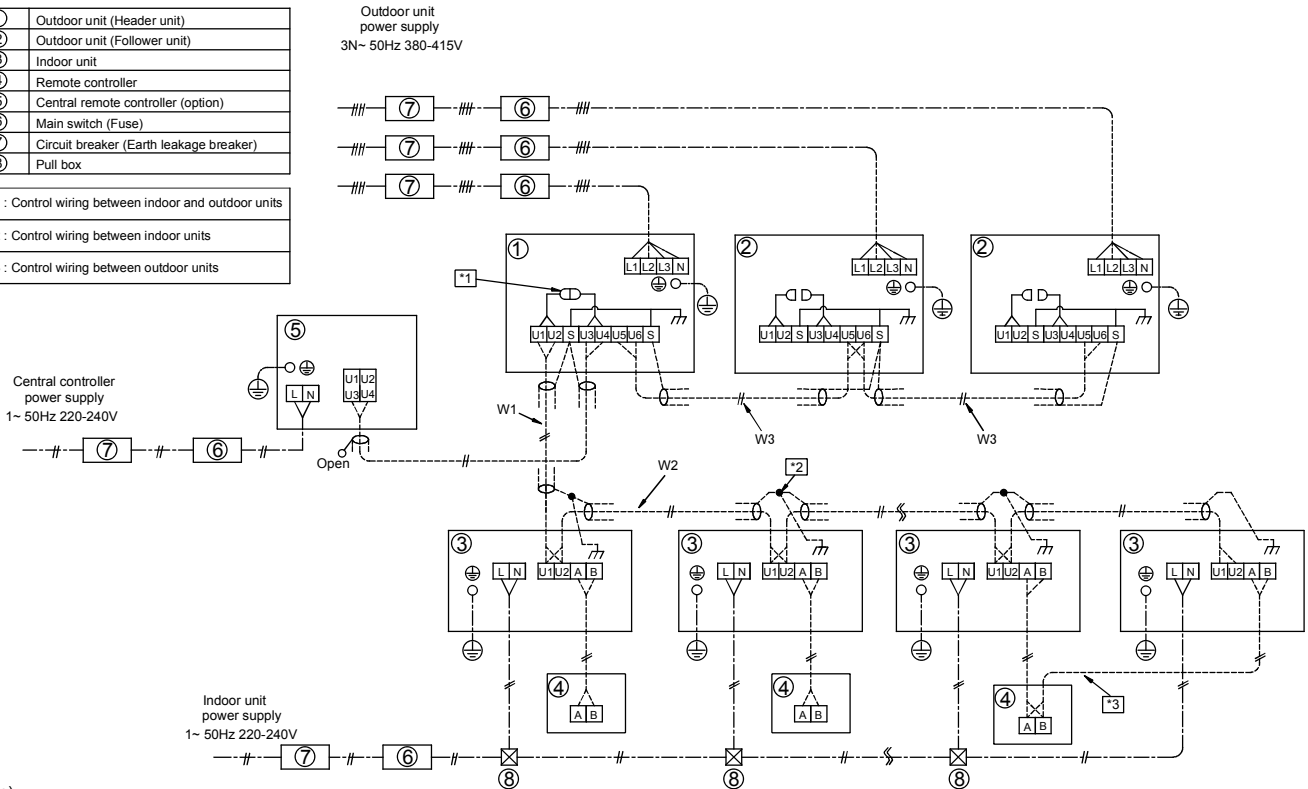

(Note)

- When perform a central control, connect the relay connector between [U1,U2] and [U3,U4] terminal of the header unit. (At shipment from factory : No connection)
- Connect the closed end terminal of shield wire.
(Connected to all connecting sections in each unit)
- Group control.
- Select the power supply wiring and fuse of outdoor/indoor units according to each model's specification.
Perform wiring of power supply complying with the rules and regulations of the local electric company.
- For the control wires connecting indoor units, outdoor units, and between indoor and outdoor units, use 2-core and non-polarity shield wires.
- As for details, see the wiring diagram of indoor/outdoor unit.
- Diagram of corrosion heavy protection model is the same as that of standard model.



5-8. Applied control for Outdoor Unit

The outdoor fan high static pressure support and priority operation mode setting (cooling / heating / number of units / or priority indoor unit) functions are made available by setting relevant switches provided on the interface P.C. board of the outdoor unit.

5-8-1. Outdoor Fan High Static Pressure Shift

Purpose/characteristics

This function is used when connecting a duct to the discharge port of an outdoor unit (as part of, for example, unit installation on the floor by floor installation.)

Setup

Turn ON the DIP switch [SW10, Bit 2] provided on the interface P.C. board of the outdoor unit. This function must be enabled with every discharge duct connected outdoor unit for both of the header and follower units.

Specification

Increase the speed of the propeller fan units on the outdoor fan to allow the installation of a duct with a maximum external static pressure not greater than specified in the table below. If a discharge duct with a resistance greater than 15 Pa (1.5 mmAq) is to be used, enable this function. The maximum external static pressures of base units are shown below (Table 1). In the case of combined use of multiple outdoor units, set all the units to the same maximum external static pressure as the one with the lowest maximum external static pressure (see Table 2).

Table 1: Maximum External Static Pressures of Base Outdoor Units

Model	MMY-	MAP0806*	MAP1006*	MAP1206*	MAP1406*	MAP1606*	MAP1806*	MAP2006*	MAP2206*	SAP0806*	SAP1006*	SAP1206*
Maximum external static pressure (Pa)		60	60	50	50	40	50	40	40	60	60	50
(*) Outdoor unit air flow (m ³ /h)		9700	9700	12200	12200	12600	17300	17900	18500	9700	9700	12200

(*) Calculate duct resistance from outdoor unit air flow.

Table 2: Maximum External Static Pressures for Combined Use of Base Units

(1) Standard models

System	Combination			Maximum external static pressure (Pa)
HP	HP			
8	8			60
10	10			60
12	12			50
14	14			50
16	16			40
18	18			50
20	20			40
22	22			40
24	12	12		50
26	14	12		50
28	16	12		40
30	16	14		40
32	16	16		40
34	18	16		40
36	20	16		40
38	22	16		40
40	20	20		40
42	22	20		40
44	22	22		40
46	16	16	14	40
48	16	16	16	40
50	18	16	16	40
52	20	16	16	40
54	22	16	16	40
56	20	20	16	40
58	22	20	16	40
60	22	22	16	40

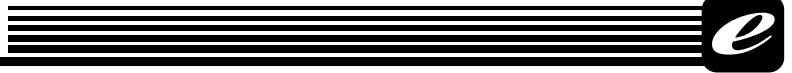

(2) High efficiency models

System	Combination			Maximum external static pressure (Pa)
HP	HP			
20	10	10		60
22	12	10		50
36	12	12	12	50
38	14	12	12	50
40	14	14	12	50
42	14	14	14	50
44	16	14	14	40
54	20	20	14	40

(3) Stand alone model

System	Combination			Maximum external static pressure (Pa)
HP	HP			
8	8			60
10	10			60
12	12			50

5-8-2. Priority Operation Mode Setting

Purpose/characteristics

This function allows switching between priority cooling and priority heating.

Four patterns of priority operation mode setting are available as shown in the table below. Select a suitable priority mode according to the needs of the customer.

Setup



In the case of the priority indoor unit mode, it is necessary to set up the specific indoor unit chosen for priority operation (a single unit only).

(1) Outdoor unit setup method (header unit)

SW11		Operation
Bit 1	Bit 2	
OFF	OFF	Priority heating (factory default)
ON	OFF	Priority cooling
OFF	ON	Priority operation based on No. of units in operation (priority given to the operation mode with the largest share of units in operation)
ON	ON	Priority indoor unit (priority given to the operation mode of the specific indoor unit set up for priority operation)



(2) Indoor unit setup method for priority indoor unit mode

The setting can be changed only when the system is at rest. (Be sure to turn off the system prior to this operation.)

- 1 Push the **TEST** + **SET** + **CL** buttons simultaneously and hold for at least 4 seconds. The display window will start flashing in a little while.

Verify that the displayed CODE No. is 10.

- If the displayed CODE No. is not 10, press the **TEST** button to erase the display and repeat the procedure from the beginning.
(Note that the system does not respond to remote controller operation for about 1 minute after the **TEST** button is pushed.)
(In the case of group control, the indoor unit No. displayed first indicates the header unit.)

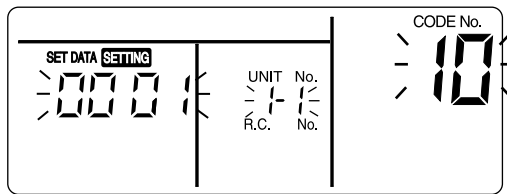
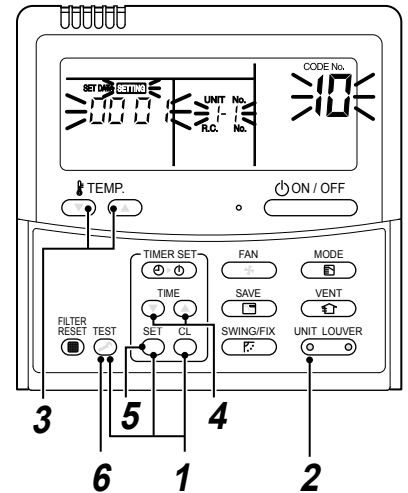

- 2 Each time the **UNIT LOUVER** button is pushed, one of the indoor unit Nos. under group control is displayed in turn. Select the indoor unit whose setting is to be changed.

The fan and flap of the selected indoor unit then come on, so that the position of this unit can be confirmed.

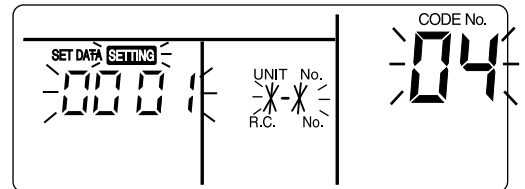

- 3 Use the **TEMP.** button to select the **CODE No. 04**.
- 4 Use the **TIME** button to select the **SET DATA 0001**.
Priority set 0001 No priority set 0000
- 5 Push the **SET** button.

The setup is finished when the display changes from flashing to steady.

- 6 Upon finishing the setup, push the **TEST** button. (This finalizes the setting.)

When the **TEST** button is pushed, the display goes blank, and the system returns to normal off state.

(Note that the system does not respond to remote controller operation for about 1 minute after the **TEST** button is pushed.)

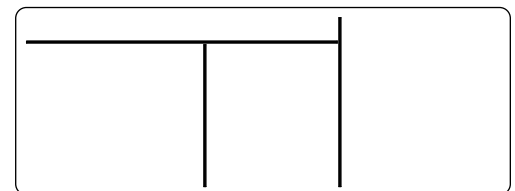

NOTE



Priority can be given to only one indoor unit. If more than one indoor unit is accidentally set to priority, an error code (L5 or L6: Duplicated indoor unit priority setting) will be displayed.

All units displaying L5 have been set to 0001 (priority). Keep the unit to which priority should be given as it is, and change the value back to 0000 (no priority) for all the rest.



Error code	Description
L5	Duplicated indoor unit priority setting (The unit is set to 0001.)
L6	Duplicated indoor unit priority setting (The unit is set to 0000.)

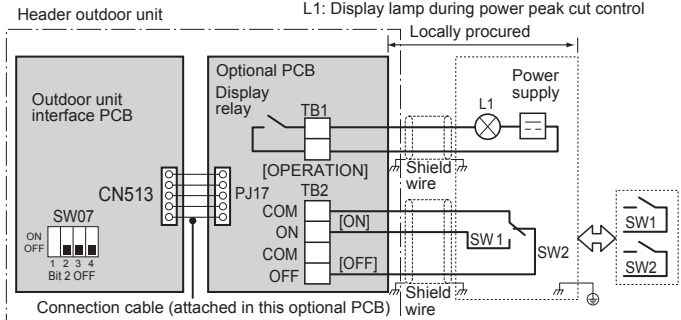
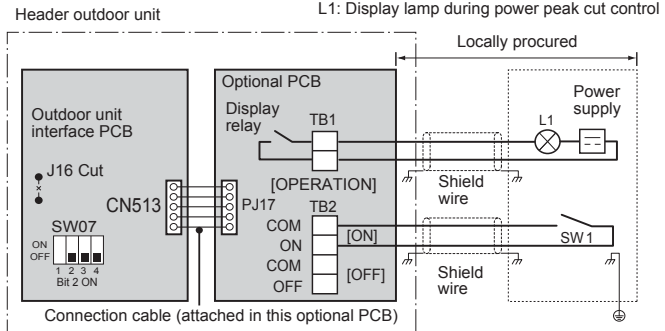

5-9. Optional printed board (PCB) of outdoor unit



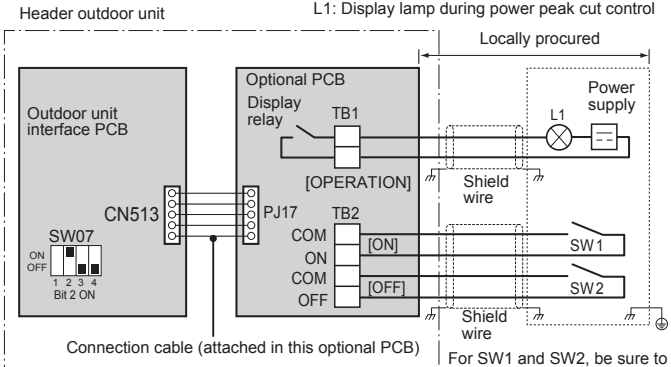







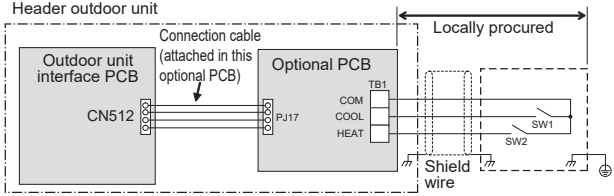

Model name	Appearance	Function																																			
TCB-PCDM4E	 <p>Size: 2.80 × 3.35 (in)</p>	<p>Power peak-cut Control <u>Standard Specifications</u> (Wiring example)</p>  <p>L1: Display lamp during power peak cut control Locally procured</p> <p>For SW1 and SW2, be sure to provide no-voltage contacts for each terminal. The input signals of SW1 and SW2 may be pulse input (100 msec or more) or continuous make. Do not turn on [SW1] and [SW2] simultaneously.</p> <p><SW07 (bit 2) OFF [2-stage switching]></p> <table border="1" data-bbox="679 1032 1369 1189"> <thead> <tr> <th colspan="2">Input</th> <th colspan="2">SW07 (bit 1)</th> <th rowspan="2">Display relay (L1)</th> </tr> <tr> <th>SW1</th> <th>SW2</th> <th>Bit 1 OFF</th> <th>Bit 1 ON</th> </tr> </thead> <tbody> <tr> <td>OFF</td> <td>ON</td> <td>100% (normal operation)</td> <td>100% (normal operation)</td> <td>OFF</td> </tr> <tr> <td>ON</td> <td>OFF</td> <td>0% (forced stop)</td> <td>Approx. 60% (upper limit regulated)</td> <td>ON</td> </tr> </tbody> </table> <p><u>For one input function</u> Power peak-cut ON-OFF control is made possible on SMMS-e and SHRM-e on the [ON]terminal input (SW1) by cutting the jumper lead(J16) of the center outdoor unit interface PCB. (Wiring example)</p>  <p>L1: Display lamp during power peak cut control Locally procured</p> <p><SW07 (bit 2) OFF [2-stage switching]> Power peak-cut control turns ON when SW1 in the wiring example is ON (continuous make).</p> <table border="1" data-bbox="679 1877 1369 2056"> <thead> <tr> <th rowspan="2">Jumper lead J16</th> <th rowspan="2">Input SW1</th> <th colspan="2">SW07 (bit 1)</th> <th rowspan="2">Display relay (L1)</th> </tr> <tr> <th>Bit 1 OFF</th> <th>Bit 1 ON</th> </tr> </thead> <tbody> <tr> <td rowspan="2">Cut</td> <td>OFF</td> <td>100% (normal operation)</td> <td>100% (normal operation)</td> <td>OFF</td> </tr> <tr> <td>ON</td> <td>0% (forced stop)</td> <td>Approx. 60% (upper limit regulated)</td> <td>ON</td> </tr> </tbody> </table>	Input		SW07 (bit 1)		Display relay (L1)	SW1	SW2	Bit 1 OFF	Bit 1 ON	OFF	ON	100% (normal operation)	100% (normal operation)	OFF	ON	OFF	0% (forced stop)	Approx. 60% (upper limit regulated)	ON	Jumper lead J16	Input SW1	SW07 (bit 1)		Display relay (L1)	Bit 1 OFF	Bit 1 ON	Cut	OFF	100% (normal operation)	100% (normal operation)	OFF	ON	0% (forced stop)	Approx. 60% (upper limit regulated)	ON
	Input		SW07 (bit 1)		Display relay (L1)																																
SW1	SW2	Bit 1 OFF	Bit 1 ON																																		
OFF	ON	100% (normal operation)	100% (normal operation)	OFF																																	
ON	OFF	0% (forced stop)	Approx. 60% (upper limit regulated)	ON																																	
Jumper lead J16	Input SW1	SW07 (bit 1)		Display relay (L1)																																	
		Bit 1 OFF	Bit 1 ON																																		
Cut	OFF	100% (normal operation)	100% (normal operation)	OFF																																	
	ON	0% (forced stop)	Approx. 60% (upper limit regulated)	ON																																	
<p>Application</p>  <p>* Install the optional PCB in the inverter assembly of the outdoor header unit.</p>																																					



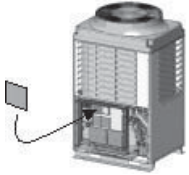
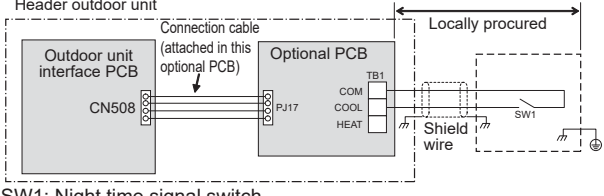

Model name	Appearance	Function																													
TCB-PCDM4E	 <p>Size: 2.80 × 3.35 (in)</p> <p style="text-align: center;">Application</p>	<p><u>Enhanced Specifications</u> (Wiring example)</p>  <p style="text-align: right; font-size: small;">For SW1 and SW2, be sure to provide no-voltage contacts for each terminal.</p> <p><SW07 (bit 2) ON [4-stage switching]></p> <table border="1" data-bbox="703 943 1390 1200"> <thead> <tr> <th colspan="2">Input</th> <th colspan="2">SW07 (bit 1)</th> <th rowspan="2">Display relay (L1)</th> </tr> <tr> <th>SW1</th> <th>SW2</th> <th>Bit 1 OFF</th> <th>Bit 1 ON</th> </tr> </thead> <tbody> <tr> <td>OFF</td> <td>OFF</td> <td>100% (normal operation)</td> <td>100% (normal operation)</td> <td>OFF</td> </tr> <tr> <td>ON</td> <td>OFF</td> <td>Approx. 80% (upper limit regulated)</td> <td>Approx. 85% (upper limit regulated)</td> <td>ON</td> </tr> <tr> <td>OFF</td> <td>ON</td> <td>Approx. 60% (upper limit regulated)</td> <td>Approx. 75% (upper limit regulated)</td> <td>ON</td> </tr> <tr> <td>ON</td> <td>ON</td> <td>0% (forced stop)</td> <td>Approx. 60% (upper limit regulated)</td> <td>ON</td> </tr> </tbody> </table>	Input		SW07 (bit 1)		Display relay (L1)	SW1	SW2	Bit 1 OFF	Bit 1 ON	OFF	OFF	100% (normal operation)	100% (normal operation)	OFF	ON	OFF	Approx. 80% (upper limit regulated)	Approx. 85% (upper limit regulated)	ON	OFF	ON	Approx. 60% (upper limit regulated)	Approx. 75% (upper limit regulated)	ON	ON	ON	0% (forced stop)	Approx. 60% (upper limit regulated)	ON
	Input		SW07 (bit 1)		Display relay (L1)																										
SW1	SW2	Bit 1 OFF	Bit 1 ON																												
OFF	OFF	100% (normal operation)	100% (normal operation)	OFF																											
ON	OFF	Approx. 80% (upper limit regulated)	Approx. 85% (upper limit regulated)	ON																											
OFF	ON	Approx. 60% (upper limit regulated)	Approx. 75% (upper limit regulated)	ON																											
ON	ON	0% (forced stop)	Approx. 60% (upper limit regulated)	ON																											
 <p>* Install the optional PCB in the inverter assembly of the outdoor header unit.</p>																															



TCB-PCMO4E

Model name	Appearance	Function																																																								
	 <p>Size: 2.19 × 2.35 (in)</p>	<p>[1] External master ON/OFF control</p> <p>▼ Function By connecting the cable (attached in this optional PCB) to the interface PC board on an outdoor unit, all indoor units connected to the outdoor unit enable to operate simultaneously.</p> <p>▼ Operation The outdoor unit connection is for the header unit (U1).</p>  <p>SW1: Operation input switch SW2: Stop input switch</p> <table border="1" data-bbox="703 801 1398 936"> <thead> <tr> <th>Terminal</th> <th>Input Signal</th> <th>Operation</th> </tr> </thead> <tbody> <tr> <td>COOL (SW1)</td> <td>ON OFF </td> <td>All indoor units operate together</td> </tr> <tr> <td>HEAT (SW2)</td> <td>ON OFF </td> <td>All indoor units stop together</td> </tr> </tbody> </table> <p>Provide no-voltage pulse contacts for each terminal. Hold the ON state for at least 100 msec. Do not turn SW1 and SW2 ON simultaneously</p>	Terminal	Input Signal	Operation	COOL (SW1)	ON OFF 	All indoor units operate together	HEAT (SW2)	ON OFF 	All indoor units stop together																																															
	Terminal	Input Signal	Operation																																																							
	COOL (SW1)	ON OFF 	All indoor units operate together																																																							
HEAT (SW2)	ON OFF 	All indoor units stop together																																																								
<p>Application</p>  <p>* Install the optional PCB in the inverter assembly of the outdoor header unit.</p>	<p>[2] Night time operation (sound reduction) control</p> <p>▼ Function As the cable (attached in this optional PCB) is connected to the "Interface PCB" on an outdoor unit, both compressor speed and fan speed are restricted while the signal of the night operation control is input. It makes the noise reduction during the night time operation.</p> <p>▼ Operation The outdoor unit connection is for the header unit (U1).</p>  <p>SW1: Night time signal switch</p> <table border="1" data-bbox="703 1518 1382 1653"> <thead> <tr> <th>Terminal</th> <th>Input Signal</th> <th>Operation</th> </tr> </thead> <tbody> <tr> <td rowspan="2">COOL (SW1)</td> <td>ON OFF </td> <td>Night time operation control</td> </tr> <tr> <td>ON OFF </td> <td>Normal operation</td> </tr> </tbody> </table> <p>Each terminal should be connected to dry contact.</p> <p>▼ Sound reduction and approximation capacity (reference)</p> <table border="1" data-bbox="703 1720 1437 2011"> <thead> <tr> <th rowspan="2"></th> <th colspan="2">Night operation sound reduction dB (A)</th> <th colspan="2">Capacity</th> </tr> <tr> <th>MAP series</th> <th>SAP series</th> <th>COOL</th> <th>HEAT</th> </tr> </thead> <tbody> <tr> <td>0806 type</td> <td>50</td> <td>51</td> <td>Approx. 85%</td> <td>Approx. 80%</td> </tr> <tr> <td>1006 type</td> <td>50</td> <td>51</td> <td>Approx. 70%</td> <td>Approx. 65%</td> </tr> <tr> <td>1206 type</td> <td>50</td> <td>51</td> <td>Approx. 60%</td> <td>Approx. 55%</td> </tr> <tr> <td>1406 type</td> <td>53</td> <td>-</td> <td>Approx. 80%</td> <td>Approx. 80%</td> </tr> <tr> <td>1606 type</td> <td>53</td> <td>-</td> <td>Approx. 70%</td> <td>Approx. 70%</td> </tr> <tr> <td>1806 type</td> <td>54</td> <td>-</td> <td>Approx. 65%</td> <td>Approx. 65%</td> </tr> <tr> <td>2006 type</td> <td>54</td> <td>-</td> <td>Approx. 60%</td> <td>Approx. 60%</td> </tr> <tr> <td>2206 type</td> <td>54</td> <td>-</td> <td>Approx. 55%</td> <td>Approx. 55%</td> </tr> </tbody> </table> <p>Condition Cooling: (Indoor 27 deg DB, 19 deg WB) (Outdoor temperature 25 deg DB) Heating: (Indoor 20 deg DB) (Outdoor temperature 7 deg DB, 6 deg WB)</p>	Terminal	Input Signal	Operation	COOL (SW1)	ON OFF 	Night time operation control	ON OFF 	Normal operation		Night operation sound reduction dB (A)		Capacity		MAP series	SAP series	COOL	HEAT	0806 type	50	51	Approx. 85%	Approx. 80%	1006 type	50	51	Approx. 70%	Approx. 65%	1206 type	50	51	Approx. 60%	Approx. 55%	1406 type	53	-	Approx. 80%	Approx. 80%	1606 type	53	-	Approx. 70%	Approx. 70%	1806 type	54	-	Approx. 65%	Approx. 65%	2006 type	54	-	Approx. 60%	Approx. 60%	2206 type	54	-	Approx. 55%	Approx. 55%
Terminal	Input Signal	Operation																																																								
COOL (SW1)	ON OFF 	Night time operation control																																																								
	ON OFF 	Normal operation																																																								
	Night operation sound reduction dB (A)		Capacity																																																							
	MAP series	SAP series	COOL	HEAT																																																						
0806 type	50	51	Approx. 85%	Approx. 80%																																																						
1006 type	50	51	Approx. 70%	Approx. 65%																																																						
1206 type	50	51	Approx. 60%	Approx. 55%																																																						
1406 type	53	-	Approx. 80%	Approx. 80%																																																						
1606 type	53	-	Approx. 70%	Approx. 70%																																																						
1806 type	54	-	Approx. 65%	Approx. 65%																																																						
2006 type	54	-	Approx. 60%	Approx. 60%																																																						
2206 type	54	-	Approx. 55%	Approx. 55%																																																						

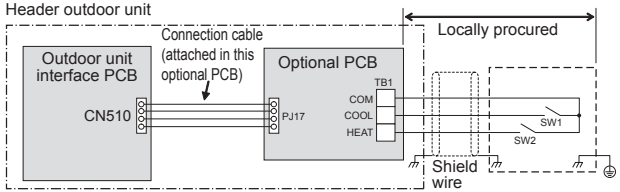

Model name	Appearance	Function																																													
TCB-PCMO4E	 <p>Size: 2.19 × 2.35 (in)</p>	<p>[3] Operation mode selection control</p> <p>▼ Function The heating/cooling mode of the system can be selected by connecting to the interface PCB of outdoor units.</p> <p>▼ Operation The outdoor unit connection is for the header unit (U1).</p> 																																													
	<p>Application</p>  <p>* Install the optional PCB in the inverter assembly of the outdoor header unit.</p>	<p>SW1: Cooling mode specified input switch SW2: Heating mode specified input switch</p> <table border="1" data-bbox="699 790 1385 931"> <thead> <tr> <th colspan="2">Input Signal</th> <th rowspan="2">Operation: Selected operation mode</th> </tr> <tr> <th>Cooling (SW1)</th> <th>Heating (SW2)</th> </tr> </thead> <tbody> <tr> <td>ON</td> <td>OFF</td> <td>Cooling operation only</td> </tr> <tr> <td>OFF</td> <td>ON</td> <td>Heating operation only</td> </tr> <tr> <td>OFF</td> <td>OFF</td> <td>Normal operation</td> </tr> </tbody> </table> <p>Each terminal should be connected to dry contact.</p> <p>The Switching of processing of Indoor Unit Operation State Processing of the operation state can be switched for indoor units in a mode other than the selected operation mode by setting the jumper lead (J01) of the header outdoor unit interface PCB.</p> <table border="1" data-bbox="699 1160 1385 1778"> <thead> <tr> <th>Jumper lead</th> <th colspan="3">Details of Processing</th> </tr> </thead> <tbody> <tr> <td rowspan="4">J01 connected (factory default)</td> <td colspan="3">Unallowed indoor units in a mode other than the selected operation mode are not treated as priority (thermo OFF state). (Unallowed indoor units)</td> </tr> <tr> <td>Operation Mode</td> <td>Operation State</td> <td>Remote control</td> </tr> <tr> <td>Cooling unit</td> <td>Air blow operation at blow rate set on remote control</td> <td rowspan="3">⏻, ⏸ indicator is displayed.</td> </tr> <tr> <td>Heating unit</td> <td>Air blow operation at super-slow blow rate</td> </tr> <tr> <td>Air blow unit</td> <td>Regular air blow operation at blow rate set on remote control</td> </tr> <tr> <td rowspan="4">J01 cut</td> <td colspan="3">Indoor units in a mode other than the selected operation mode are forcibly switched to the selected operation mode.</td> </tr> <tr> <td>PC board selection mode</td> <td colspan="2">Remote control operation/display</td> </tr> <tr> <td>Normal</td> <td>*, ∆, ✱, or ✨ can be selected</td> <td rowspan="3">When using the remote control, ⏻ (mode select control) indicator is displayed.</td> </tr> <tr> <td>Cool</td> <td>Only ✱, ∆, or ✨ can be selected</td> </tr> <tr> <td>Heat</td> <td>Only ✱ or ✨ can be selected</td> </tr> </tbody> </table>	Input Signal		Operation: Selected operation mode	Cooling (SW1)	Heating (SW2)	ON	OFF	Cooling operation only	OFF	ON	Heating operation only	OFF	OFF	Normal operation	Jumper lead	Details of Processing			J01 connected (factory default)	Unallowed indoor units in a mode other than the selected operation mode are not treated as priority (thermo OFF state). (Unallowed indoor units)			Operation Mode	Operation State	Remote control	Cooling unit	Air blow operation at blow rate set on remote control	⏻, ⏸ indicator is displayed.	Heating unit	Air blow operation at super-slow blow rate	Air blow unit	Regular air blow operation at blow rate set on remote control	J01 cut	Indoor units in a mode other than the selected operation mode are forcibly switched to the selected operation mode.			PC board selection mode	Remote control operation/display		Normal	*, ∆, ✱, or ✨ can be selected	When using the remote control, ⏻ (mode select control) indicator is displayed.	Cool	Only ✱, ∆, or ✨ can be selected	Heat
Input Signal		Operation: Selected operation mode																																													
Cooling (SW1)	Heating (SW2)																																														
ON	OFF	Cooling operation only																																													
OFF	ON	Heating operation only																																													
OFF	OFF	Normal operation																																													
Jumper lead	Details of Processing																																														
J01 connected (factory default)	Unallowed indoor units in a mode other than the selected operation mode are not treated as priority (thermo OFF state). (Unallowed indoor units)																																														
	Operation Mode	Operation State	Remote control																																												
	Cooling unit	Air blow operation at blow rate set on remote control	⏻, ⏸ indicator is displayed.																																												
	Heating unit	Air blow operation at super-slow blow rate																																													
Air blow unit	Regular air blow operation at blow rate set on remote control																																														
J01 cut	Indoor units in a mode other than the selected operation mode are forcibly switched to the selected operation mode.																																														
	PC board selection mode	Remote control operation/display																																													
	Normal	*, ∆, ✱, or ✨ can be selected	When using the remote control, ⏻ (mode select control) indicator is displayed.																																												
	Cool	Only ✱, ∆, or ✨ can be selected																																													
Heat	Only ✱ or ✨ can be selected																																														

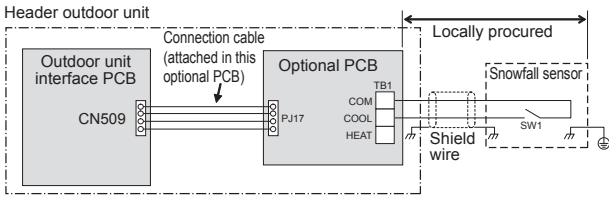
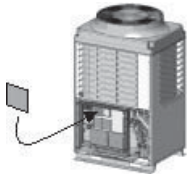

Model name	Appearance	Function														
TCB-PCMO4E		<p>[4] Snowfall fan control</p> <p>▼ Function The outdoor unit fan operates at snowfall by connecting to the outdoor unit interface PCB.</p> <p>▼ Operation</p> <div style="border: 1px dashed black; padding: 5px;">  </div> <p>SW1: Snowfall detection switch (snowfall sensor)</p> <table border="1" style="width: 100%; border-collapse: collapse;"> <thead> <tr> <th>Terminal</th> <th>Input Signal</th> <th>Operation</th> </tr> </thead> <tbody> <tr> <td rowspan="4" style="text-align: center;">Cooling (SW1)</td> <td>ON</td> <td style="text-align: center;">▲</td> <td rowspan="2">Snowfall fan control (Fan in outdoor unit operates.)</td> </tr> <tr> <td>OFF</td> <td style="text-align: center;">▼</td> </tr> <tr> <td>ON</td> <td style="text-align: center;">▲</td> <td rowspan="2">Normal operation</td> </tr> <tr> <td>OFF</td> <td style="text-align: center;">▼</td> </tr> </tbody> </table> <p style="text-align: center;">Provide no-voltage continuous contacts for each terminal.</p>	Terminal	Input Signal	Operation	Cooling (SW1)	ON	▲	Snowfall fan control (Fan in outdoor unit operates.)	OFF	▼	ON	▲	Normal operation	OFF	▼
	Terminal		Input Signal	Operation												
	Cooling (SW1)		ON	▲	Snowfall fan control (Fan in outdoor unit operates.)											
OFF		▼														
ON		▲	Normal operation													
OFF		▼														
<p>Size: 2.19 × 2.35 (in)</p> <p>Application</p>																
 <p>* Install the optional PCB in the inverter assembly of the outdoor header unit.</p>																

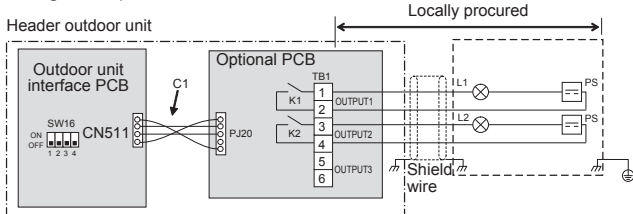
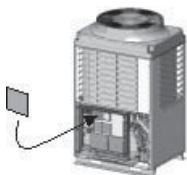
Model name	Appearance	Function																				
TCB-PCIN4E		<p>[1] Error / Operation Output</p> <p>▼ Function The operation error output PCB can indicate operation and error states by connecting to the interface PCB of outdoor units.</p> <p>▼ Operation</p> <p>Operation output: The operation indicator is on while any indoor unit in the system is operating.</p> <p>Error output: The error indicator is on when an error is occurred on even one of the indoor or outdoor units in the system.</p> <p>Wiring example</p> <div style="border: 1px dashed black; padding: 5px;">  </div> <table border="1" style="width: 100%; border-collapse: collapse;"> <tbody> <tr> <td>C1</td> <td>Attached connection cable 1 (4wires)</td> </tr> <tr> <td>CN511</td> <td>Connector on interface side (green)</td> </tr> <tr> <td>K1, K2</td> <td>Relays</td> </tr> <tr> <td>L1</td> <td>Error indication Lamp</td> </tr> <tr> <td>L2</td> <td>Operation indication Lamp</td> </tr> <tr> <td>OUTPUT1</td> <td>Error output</td> </tr> <tr> <td>OUTPUT2</td> <td>Operation output</td> </tr> <tr> <td>PJ20</td> <td>Connector on optional PCB side</td> </tr> <tr> <td>PS</td> <td>Power supply unit</td> </tr> <tr> <td>TB1</td> <td>Terminal block</td> </tr> </tbody> </table> <p>* [OUTPUT3] is displayed when power is turned on.</p>	C1	Attached connection cable 1 (4wires)	CN511	Connector on interface side (green)	K1, K2	Relays	L1	Error indication Lamp	L2	Operation indication Lamp	OUTPUT1	Error output	OUTPUT2	Operation output	PJ20	Connector on optional PCB side	PS	Power supply unit	TB1	Terminal block
	C1		Attached connection cable 1 (4wires)																			
	CN511		Connector on interface side (green)																			
K1, K2	Relays																					
L1	Error indication Lamp																					
L2	Operation indication Lamp																					
OUTPUT1	Error output																					
OUTPUT2	Operation output																					
PJ20	Connector on optional PCB side																					
PS	Power supply unit																					
TB1	Terminal block																					
<p>Size: 2.87 × 3.11 (in)</p> <p>Application</p>																						
 <p>* Install the optional PCB in the inverter assembly of the outdoor header unit.</p>																						

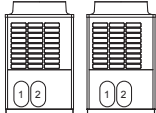
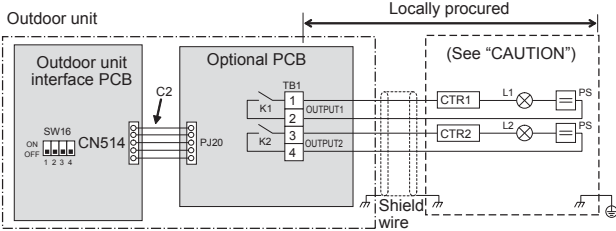
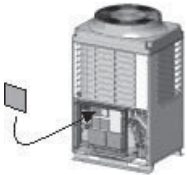

Model name	Appearance	Function																						
TCB-PCIN4E	 <p>Size: 2.87 × 3.11 (in)</p>	<p>[2] Compressor Operation Output</p> <p>▼ Function While each compressor in the outdoor unit is running, the compressor operation signal is displayed. This function can also be used to measure the elapsed time for the compressor operation.</p> <p>▼ Operation During a compressor is in operation, the relay of the output terminal corresponding to that compressor turns on (closed) and turns OFF (opens) . When operation stops.</p> <p>As shown in the figure, the output terminals “OUTPUT1”, “OUTPUT2” from the left compressors facing to the front of the outdoor unit.</p>  <p>Wiring example</p>  <table border="1" data-bbox="719 1025 1401 1339"> <tr> <td>C2</td> <td>Connection cable 2 ([2])</td> </tr> <tr> <td>CN514</td> <td>Connector on interface side (green)</td> </tr> <tr> <td>CTR1</td> <td>Elapsed operation counter 1</td> </tr> <tr> <td>CTR2</td> <td>Elapsed operation counter 2</td> </tr> <tr> <td>K1, K2</td> <td>Relays</td> </tr> <tr> <td>L1, L2, L3</td> <td>Operation indication LEDs</td> </tr> <tr> <td>OUTPUT1</td> <td>Compressor 1 operation output terminal</td> </tr> <tr> <td>OUTPUT2</td> <td>Compressor 2 operation output terminal</td> </tr> <tr> <td>PJ20</td> <td>Connector on optional PCB side</td> </tr> <tr> <td>PS</td> <td>Power supply unit</td> </tr> <tr> <td>TB1</td> <td>Terminal block</td> </tr> </table>	C2	Connection cable 2 ([2])	CN514	Connector on interface side (green)	CTR1	Elapsed operation counter 1	CTR2	Elapsed operation counter 2	K1, K2	Relays	L1, L2, L3	Operation indication LEDs	OUTPUT1	Compressor 1 operation output terminal	OUTPUT2	Compressor 2 operation output terminal	PJ20	Connector on optional PCB side	PS	Power supply unit	TB1	Terminal block
	C2		Connection cable 2 ([2])																					
	CN514		Connector on interface side (green)																					
CTR1	Elapsed operation counter 1																							
CTR2	Elapsed operation counter 2																							
K1, K2	Relays																							
L1, L2, L3	Operation indication LEDs																							
OUTPUT1	Compressor 1 operation output terminal																							
OUTPUT2	Compressor 2 operation output terminal																							
PJ20	Connector on optional PCB side																							
PS	Power supply unit																							
TB1	Terminal block																							
Application	 <p>* Install the optional PCB in the inverter assembly of individual outdoor unit.</p>																							

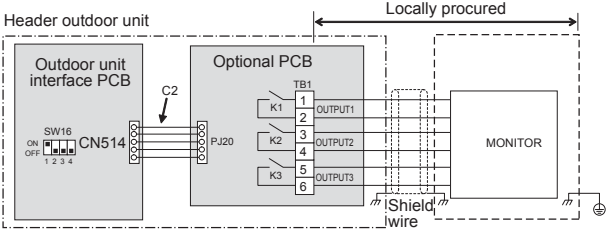
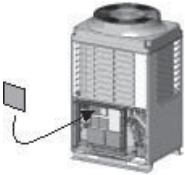

Model name	Appearance	Function																																																																	
TCB-PCIN4E	 <p style="text-align: center;">Size: 2.87 × 3.11 (in)</p> <p style="text-align: center;">Application</p>	<p>[3] Operating Rate Output</p> <p>▼ Function The state of operation is available to check remotely as the signal of system operation rate enable to output.</p> <p>▼ Operation As shown in the table, each of the output terminals turns ON (relay closes) and OFF (relay opens) depending on the system operating rate.</p> <table border="1" data-bbox="730 562 1417 808"> <thead> <tr> <th>Functions</th> <th>SW16</th> <th>OUTPUT1</th> <th>OUTPUT2</th> <th>OUTPUT3</th> <th>Operating rate FA</th> </tr> </thead> <tbody> <tr> <td rowspan="8" style="text-align: center;">System operating rate output</td> <td>OFF</td> <td>OFF</td> <td>OFF</td> <td>OFF</td> <td>FA = 0%</td> </tr> <tr> <td>ON</td> <td>OFF</td> <td>OFF</td> <td>OFF</td> <td>0% < FA < 20%</td> </tr> <tr> <td>ON</td> <td>ON</td> <td>OFF</td> <td>OFF</td> <td>20% ≤ FA < 35%</td> </tr> <tr> <td>ON</td> <td>ON</td> <td>ON</td> <td>OFF</td> <td>35% ≤ FA < 50%</td> </tr> <tr> <td>ON</td> <td>OFF</td> <td>OFF</td> <td>ON</td> <td>50% ≤ FA < 65%</td> </tr> <tr> <td>ON</td> <td>OFF</td> <td>OFF</td> <td>ON</td> <td>65% ≤ FA < 80%</td> </tr> <tr> <td>ON</td> <td>ON</td> <td>ON</td> <td>ON</td> <td>80% ≤ FA < 95%</td> </tr> <tr> <td>ON</td> <td>ON</td> <td>ON</td> <td>ON</td> <td>95% ≤ FA</td> </tr> </tbody> </table> <p style="text-align: right;">OFF=relay open ON=relay closed</p> <p>Wiring example</p>  <table border="1" data-bbox="730 1137 1417 1391"> <tbody> <tr> <td>C2</td> <td>Attached connection cable 2 (5wires)</td> </tr> <tr> <td>CN514</td> <td>Connector on interface side (green)</td> </tr> <tr> <td>K1, K2, K3</td> <td>Relays</td> </tr> <tr> <td>MONITOR</td> <td>Monitoring device</td> </tr> <tr> <td>OUTPUT1</td> <td>Output terminal for each function</td> </tr> <tr> <td>OUTPUT2</td> <td>Output terminal for each function</td> </tr> <tr> <td>OUTPUT3</td> <td>Output terminal for each function</td> </tr> <tr> <td>PJ20</td> <td>Connector on optional PCB side</td> </tr> <tr> <td>TB1</td> <td>Terminal block</td> </tr> </tbody> </table>	Functions	SW16	OUTPUT1	OUTPUT2	OUTPUT3	Operating rate FA	System operating rate output	OFF	OFF	OFF	OFF	FA = 0%	ON	OFF	OFF	OFF	0% < FA < 20%	ON	ON	OFF	OFF	20% ≤ FA < 35%	ON	ON	ON	OFF	35% ≤ FA < 50%	ON	OFF	OFF	ON	50% ≤ FA < 65%	ON	OFF	OFF	ON	65% ≤ FA < 80%	ON	ON	ON	ON	80% ≤ FA < 95%	ON	ON	ON	ON	95% ≤ FA	C2	Attached connection cable 2 (5wires)	CN514	Connector on interface side (green)	K1, K2, K3	Relays	MONITOR	Monitoring device	OUTPUT1	Output terminal for each function	OUTPUT2	Output terminal for each function	OUTPUT3	Output terminal for each function	PJ20	Connector on optional PCB side	TB1	Terminal block
	Functions	SW16	OUTPUT1	OUTPUT2	OUTPUT3	Operating rate FA																																																													
System operating rate output	OFF	OFF	OFF	OFF	FA = 0%																																																														
	ON	OFF	OFF	OFF	0% < FA < 20%																																																														
	ON	ON	OFF	OFF	20% ≤ FA < 35%																																																														
	ON	ON	ON	OFF	35% ≤ FA < 50%																																																														
	ON	OFF	OFF	ON	50% ≤ FA < 65%																																																														
	ON	OFF	OFF	ON	65% ≤ FA < 80%																																																														
	ON	ON	ON	ON	80% ≤ FA < 95%																																																														
	ON	ON	ON	ON	95% ≤ FA																																																														
C2	Attached connection cable 2 (5wires)																																																																		
CN514	Connector on interface side (green)																																																																		
K1, K2, K3	Relays																																																																		
MONITOR	Monitoring device																																																																		
OUTPUT1	Output terminal for each function																																																																		
OUTPUT2	Output terminal for each function																																																																		
OUTPUT3	Output terminal for each function																																																																		
PJ20	Connector on optional PCB side																																																																		
TB1	Terminal block																																																																		
 <p>* Install the optional PCB in the inverter assembly of the outdoor header unit.</p>																																																																			



5-10. Part Load performance

MMY-MAP0806HT8P-E (8HP, 22.4kW system)

Cooling		Compressor + Outdoor Fan Power consumption (kW)															
Outdoor Unit Dry-Bulb (°C)	Outdoor Unit 100% Cooling Capacity (kW)	100% Capacity		90% Capacity		80% Capacity		70% Capacity		60% Capacity		50% Capacity		40% Capacity		30% Capacity	
		TC	PI	TC	PI	TC	PI	TC	PI	TC	PI	TC	PI	TC	PI	TC	PI
		(kW)	(kW)	(kW)	(kW)	(kW)	(kW)	(kW)	(kW)	(kW)	(kW)	(kW)	(kW)	(kW)	(kW)	(kW)	(kW)
40 °C	20.8	20.8	5.99	18.8	4.85	16.7	3.89	14.6	3.09	12.5	2.43	10.4	1.89	8.34	1.47	6.25	1.15
39 °C	21.2	21.2	5.90	19.1	4.78	16.9	3.84	14.8	3.04	12.7	2.39	10.6	1.87	8.47	1.45	6.35	1.13
37 °C	21.8	21.8	5.72	19.6	4.64	17.5	3.72	15.3	2.95	13.1	2.32	10.9	1.81	8.73	1.41	6.54	1.10
35 °C	22.4	22.4	5.54	20.2	4.49	17.9	3.60	15.7	2.86	13.4	2.25	11.2	1.75	8.96	1.36	6.72	1.06
32 °C	22.4	22.4	5.10	20.2	4.15	17.9	3.34	15.7	2.66	13.4	2.10	11.2	1.65	8.96	1.29	6.72	1.01
31 °C	22.4	22.4	4.72	20.2	3.85	17.9	3.10	15.7	2.48	13.4	1.97	11.2	1.55	8.96	1.22	6.72	0.96
30 °C	22.4	22.4	4.55	20.2	3.71	17.9	3.00	15.7	2.40	13.4	1.90	11.2	1.50	8.96	1.18	6.72	0.94
29 °C	22.4	22.4	4.38	20.2	3.58	17.9	2.89	15.7	2.32	13.4	1.84	11.2	1.46	8.96	1.15	6.72	0.91
27 °C	22.4	22.4	4.08	20.2	3.34	17.9	2.70	15.7	2.17	13.4	1.73	11.2	1.38	8.96	1.09	6.72	0.87
25 °C	22.4	22.4	3.80	20.2	3.11	17.9	2.53	15.7	2.04	13.4	1.63	11.2	1.30	8.96	1.03	6.72	0.83
23 °C	22.4	22.4	3.62	20.2	2.97	17.9	2.42	15.7	1.95	13.4	1.57	11.2	1.25	8.96	1.00	6.72	0.80
21 °C	22.4	22.4	3.54	20.2	2.91	17.9	2.37	15.7	1.92	13.4	1.54	11.2	1.23	8.96	0.99	6.72	0.80
20 °C	22.4	22.4	3.51	20.2	2.88	17.9	2.35	15.7	1.90	13.4	1.53	11.2	1.23	8.96	0.98	6.72	0.79
19 °C	22.4	22.4	3.47	20.2	2.86	17.9	2.33	15.7	1.89	13.4	1.52	11.2	1.22	8.96	0.98	6.72	0.79
17 °C	22.4	22.4	3.41	20.2	2.81	17.9	2.30	15.7	1.86	13.4	1.50	11.2	1.21	8.96	0.97	6.72	0.79
15 °C	22.4	22.4	3.36	20.2	2.77	17.9	2.27	15.7	1.84	13.4	1.49	11.2	1.20	8.96	0.97	6.72	0.78

TC : Total Capacity PI : Power Input
Indoor air temperature conditions : 27.0°C dry-bulb / 19.0°C wet bulb

Heating			Compressor + Outdoor Fan Power consumption (kW)															
Outdoor Unit Dry-Bulb (°C)	Outdoor Unit Wet-Bulb (°C)	Outdoor Unit 100% Heating Capacity (kW)	100% Capacity		90% Capacity		80% Capacity		70% Capacity		60% Capacity		50% Capacity		40% Capacity		30% Capacity	
			TC	PI	TC	PI	TC	PI	TC	PI	TC	PI	TC	PI	TC	PI	TC	PI
			(kW)	(kW)	(kW)	(kW)	(kW)	(kW)	(kW)	(kW)	(kW)	(kW)	(kW)	(kW)	(kW)	(kW)	(kW)	(kW)
15.0	13.7	25.0	25.0	4.48	22.5	3.71	20.0	3.07	17.5	2.55	15.0	2.12	12.5	1.75	10.0	1.43	7.50	1.12
13.0	11.8	25.0	25.0	4.69	22.5	3.87	20.0	3.19	17.5	2.63	15.0	2.18	12.5	1.79	10.0	1.46	7.50	1.14
11.0	9.8	25.0	25.0	4.95	22.5	4.06	20.0	3.32	17.5	2.73	15.0	2.24	12.5	1.84	10.0	1.49	7.50	1.17
9.0	7.9	25.0	25.0	5.22	22.5	4.25	20.0	3.47	17.5	2.83	15.0	2.31	12.5	1.89	10.0	1.52	7.50	1.19
7.0	6.0	25.0	25.0	5.53	22.5	4.48	20.0	3.62	17.5	2.94	15.0	2.39	12.5	1.94	10.0	1.56	7.50	1.21
5.0	4.1	24.3	24.3	5.51	21.8	4.46	19.4	3.61	17.0	2.93	14.6	2.38	12.1	1.93	9.7	1.55	7.28	1.21
3.0	2.2	23.5	23.5	5.50	21.2	4.45	18.8	3.60	16.5	2.92	14.1	2.37	11.8	1.93	9.4	1.55	7.06	1.21
0.0	-0.7	22.4	22.4	5.47	20.2	4.43	17.9	3.59	15.7	2.91	13.5	2.36	11.2	1.92	9.0	1.54	6.73	1.20
-3.0	-3.7	21.3	21.3	5.44	19.1	4.41	17.0	3.57	14.9	2.89	12.8	2.35	10.6	1.91	8.5	1.54	6.38	1.20
-5.0	-5.6	20.5	20.5	5.43	18.5	4.39	16.4	3.56	14.4	2.89	12.3	2.34	10.3	1.90	8.2	1.53	6.16	1.19
-7.0	-7.6	19.8	19.8	5.41	17.8	4.38	15.8	3.55	13.8	2.88	11.9	2.34	9.9	1.90	7.9	1.53	5.93	1.19
-10	-10.5	18.7	18.7	5.38	16.8	4.36	14.9	3.53	13.1	2.86	11.2	2.33	9.3	1.89	7.5	1.52	5.60	1.18
-14.5	-15.0	16.9	16.9	5.34	15.2	4.33	13.5	3.50	11.8	2.84	10.2	2.31	8.5	1.87	6.8	1.51	5.08	1.17

TC : Total Capacity PI : Power Input
Indoor air temperature conditions : 20.0°C dry-bulb



MMY-MAP1006HT8P-E (10HP, 28kW system)

Outdoor Unit Dry-Bulb (°C)		Outdoor Unit 100% Cooling Capacity (kW)	Compressor + Outdoor Fan Power consumption (kW)															
			100% Capacity		90% Capacity		80% Capacity		70% Capacity		60% Capacity		50% Capacity		40% Capacity		30% Capacity	
			TC	PI	TC	PI	TC	PI	TC	PI	TC	PI	TC	PI	TC	PI	TC	PI
			(kW)	(kW)	(kW)	(kW)	(kW)	(kW)	(kW)	(kW)	(kW)	(kW)	(kW)	(kW)	(kW)	(kW)	(kW)	(kW)
40 °C	26.1	26.1	8.31	23.5	6.77	20.8	5.41	18.2	4.24	15.6	3.24	13.0	2.43	10.42	1.82	7.82	1.39	
39 °C	26.5	26.5	8.19	23.8	6.67	21.2	5.33	18.5	4.17	15.9	3.19	13.2	2.40	10.59	1.79	7.94	1.37	
37 °C	27.3	27.3	7.94	24.5	6.47	21.8	5.17	19.1	4.05	16.4	3.10	13.6	2.33	10.91	1.73	8.18	1.33	
35 °C	28.0	28.0	7.69	25.2	6.26	22.4	5.01	19.6	3.92	16.8	3.00	14.0	2.25	11.20	1.68	8.40	1.28	
32 °C	28.0	28.0	7.10	25.2	5.79	22.4	4.63	19.6	3.63	16.8	2.79	14.0	2.10	11.20	1.58	8.40	1.22	
31 °C	28.0	28.0	6.57	25.2	5.37	22.4	4.30	19.6	3.38	16.8	2.60	14.0	1.97	11.20	1.49	8.40	1.16	
30 °C	28.0	28.0	6.33	25.2	5.17	22.4	4.15	19.6	3.26	16.8	2.51	14.0	1.91	11.20	1.45	8.40	1.13	
29 °C	28.0	28.0	6.11	25.2	4.99	22.4	4.00	19.6	3.15	16.8	2.43	14.0	1.85	11.20	1.41	8.40	1.11	
27 °C	28.0	28.0	5.68	25.2	4.65	22.4	3.73	19.6	2.94	16.8	2.28	14.0	1.74	11.20	1.33	8.40	1.05	
25 °C	28.0	28.0	5.30	25.2	4.33	22.4	3.48	19.6	2.75	16.8	2.13	14.0	1.64	11.20	1.26	8.40	1.00	
23 °C	28.0	28.0	5.06	25.2	4.14	22.4	3.33	19.6	2.63	16.8	2.05	14.0	1.57	11.20	1.22	8.40	0.97	
21 °C	28.0	28.0	4.94	25.2	4.05	22.4	3.26	19.6	2.58	16.8	2.01	14.0	1.55	11.20	1.20	8.40	0.97	
20 °C	28.0	28.0	4.89	25.2	4.01	22.4	3.23	19.6	2.55	16.8	1.99	14.0	1.54	11.20	1.19	8.40	0.96	
19 °C	28.0	28.0	4.84	25.2	3.97	22.4	3.20	19.6	2.53	16.8	1.98	14.0	1.53	11.20	1.19	8.40	0.96	
17 °C	28.0	28.0	4.76	25.2	3.90	22.4	3.15	19.6	2.49	16.8	1.95	14.0	1.51	11.20	1.18	8.40	0.96	
15 °C	28.0	28.0	4.69	25.2	3.84	22.4	3.10	19.6	2.46	16.8	1.93	14.0	1.49	11.20	1.17	8.40	0.95	

TC : Total Capacity PI : Power Input
Indoor air temperature conditions : 27.0°C dry-bulb / 19.0°C wet bulb

Outdoor Unit Dry-Bulb (°C)		Outdoor Unit 100% Heating Capacity (kW)	Wet-Bulb (°C)	Compressor + Outdoor Fan Power consumption (kW)															
				100% Capacity		90% Capacity		80% Capacity		70% Capacity		60% Capacity		50% Capacity		40% Capacity		30% Capacity	
				TC	PI	TC	PI	TC	PI	TC	PI	TC	PI	TC	PI	TC	PI	TC	PI
				(kW)	(kW)	(kW)	(kW)	(kW)	(kW)	(kW)	(kW)	(kW)	(kW)	(kW)	(kW)	(kW)	(kW)	(kW)	(kW)
15.0	13.7	31.5	31.5	5.98	28.4	4.96	25.2	4.12	22.1	3.44	18.9	2.88	15.8	2.38	12.6	1.90	9.45	1.42	
13.0	11.8	31.5	31.5	6.27	28.4	5.17	25.2	4.28	22.1	3.55	18.9	2.95	15.8	2.43	12.6	1.95	9.45	1.45	
11.0	9.8	31.5	31.5	6.62	28.4	5.42	25.2	4.45	22.1	3.68	18.9	3.04	15.8	2.50	12.6	2.00	9.45	1.49	
9.0	7.9	31.5	31.5	6.99	28.4	5.68	25.2	4.64	22.1	3.81	18.9	3.13	15.8	2.56	12.6	2.05	9.45	1.53	
7.0	6.0	31.5	31.5	7.41	28.4	5.98	25.2	4.85	22.1	3.95	18.9	3.23	15.8	2.63	12.6	2.10	9.45	1.57	
5.0	4.1	30.5	30.5	7.37	27.4	5.95	24.4	4.82	21.3	3.93	18.3	3.21	15.2	2.62	12.2	2.09	9.15	1.57	
3.0	2.2	29.5	29.5	7.32	26.5	5.91	23.6	4.79	20.6	3.90	17.7	3.19	14.7	2.60	11.8	2.08	8.84	1.56	
0.0	-0.7	27.9	27.9	7.26	25.1	5.86	22.3	4.75	19.5	3.87	16.8	3.17	14.0	2.58	11.2	2.06	8.38	1.54	
-3.0	-3.7	26.3	26.3	7.19	23.7	5.81	21.1	4.71	18.4	3.83	15.8	3.14	13.2	2.56	10.5	2.04	7.90	1.53	
-5.0	-5.6	25.3	25.3	7.15	22.8	5.77	20.3	4.68	17.7	3.81	15.2	3.12	12.7	2.54	10.1	2.03	7.59	1.52	
-7.0	-7.6	24.2	24.2	7.11	21.8	5.74	19.4	4.65	17.0	3.79	14.5	3.10	12.1	2.53	9.7	2.01	7.27	1.51	
-10	-10.5	22.7	22.7	7.04	20.4	5.68	18.2	4.61	15.9	3.75	13.6	3.07	11.4	2.50	9.1	2.00	6.81	1.50	
-14.5	-15.0	20.3	20.3	6.94	18.3	5.60	16.2	4.54	14.2	3.70	12.2	3.03	10.2	2.47	8.1	1.97	6.09	1.48	

TC : Total Capacity PI : Power Input
Indoor air temperature conditions : 20.0°C dry-bulb



MMY-MAP1206HT8P-E (12HP, 33.5kW system)

Outdoor Unit Dry-Bulb (°C)		Outdoor Unit 100% Cooling Capacity (kW)	Compressor + Outdoor Fan Power consumption (kW)															
			100% Capacity		90% Capacity		80% Capacity		70% Capacity		60% Capacity		50% Capacity		40% Capacity		30% Capacity	
			TC	PI	TC	PI	TC	PI	TC	PI	TC	PI	TC	PI	TC	PI	TC	PI
			(kW)	(kW)	(kW)	(kW)	(kW)	(kW)	(kW)	(kW)	(kW)	(kW)	(kW)	(kW)	(kW)	(kW)	(kW)	(kW)
40 °C		31.2	31.2	10.8	28.1	8.65	24.9	6.85	21.8	5.35	18.7	4.11	15.6	3.09	12.47	2.24	9.35	1.54
39 °C		31.7	31.7	10.6	28.5	8.53	25.3	6.75	22.2	5.27	19.0	4.05	15.8	3.04	12.67	2.21	9.50	1.51
37 °C		32.6	32.6	10.3	29.4	8.27	26.1	6.54	22.8	5.11	19.6	3.92	16.3	2.95	13.05	2.14	9.79	1.47
35 °C		33.5	33.5	10.0	30.1	8.01	26.8	6.34	23.4	4.95	20.1	3.80	16.7	2.86	13.40	2.08	10.05	1.42
32 °C		33.5	33.5	9.19	30.2	7.38	26.8	5.86	23.5	4.59	20.1	3.54	16.8	2.67	13.40	1.94	10.05	1.33
31 °C		33.5	33.5	8.48	30.2	6.83	26.8	5.43	23.5	4.27	20.1	3.30	16.8	2.49	13.40	1.82	10.05	1.25
30 °C		33.5	33.5	8.15	30.2	6.57	26.8	5.24	23.5	4.12	20.1	3.19	16.8	2.41	13.40	1.77	10.05	1.22
29 °C		33.5	33.5	7.85	30.2	6.33	26.8	5.05	23.5	3.98	20.1	3.08	16.8	2.34	13.40	1.71	10.05	1.18
27 °C		33.5	33.5	7.29	30.2	5.89	26.8	4.71	23.5	3.72	20.1	2.89	16.8	2.19	13.40	1.61	10.05	1.11
25 °C		33.5	33.5	6.78	30.2	5.49	26.8	4.40	23.5	3.48	20.1	2.71	16.8	2.06	13.40	1.52	10.05	1.05
23 °C		33.5	33.5	6.46	30.2	5.24	26.8	4.20	23.5	3.33	20.1	2.60	16.8	1.98	13.40	1.46	10.05	1.01
21 °C		33.5	33.5	6.30	30.2	5.12	26.8	4.11	23.5	3.26	20.1	2.55	16.8	1.95	13.40	1.43	10.05	0.99
20 °C		33.5	33.5	6.24	30.2	5.07	26.8	4.07	23.5	3.23	20.1	2.53	16.8	1.93	13.40	1.42	10.05	0.99
19 °C		33.5	33.5	6.17	30.2	5.02	26.8	4.04	23.5	3.21	20.1	2.51	16.8	1.92	13.40	1.42	10.05	0.98
17 °C		33.5	33.5	6.06	30.2	4.93	26.8	3.97	23.5	3.16	20.1	2.47	16.8	1.89	13.40	1.40	10.05	0.97
15 °C		33.5	33.5	5.96	30.2	4.86	26.8	3.92	23.5	3.12	20.1	2.44	16.8	1.87	13.40	1.38	10.05	0.96

TC : Total Capacity PI : Power Input
Indoor air temperature conditions : 27.0°C dry-bulb / 19.0°C wet bulb

Outdoor Unit Dry-Bulb (°C)		Outdoor Unit 100% Heating Capacity (kW)	Wet-Bulb (°C)	Compressor + Outdoor Fan Power consumption (kW)															
				100% Capacity		90% Capacity		80% Capacity		70% Capacity		60% Capacity		50% Capacity		40% Capacity		30% Capacity	
				TC	PI	TC	PI	TC	PI	TC	PI	TC	PI	TC	PI	TC	PI	TC	PI
				(kW)	(kW)	(kW)	(kW)	(kW)	(kW)	(kW)	(kW)	(kW)	(kW)	(kW)	(kW)	(kW)	(kW)	(kW)	(kW)
15.0	13.7	37.5		37.5	7.91	33.8	6.62	30.0	5.53	26.3	4.61	22.5	3.80	18.8	3.08	15.0	2.39	11.3	1.70
13.0	11.8	37.5		37.5	8.28	33.8	6.89	30.0	5.73	26.3	4.76	22.5	3.92	18.8	3.17	15.0	2.46	11.3	1.75
11.0	9.8	37.5		37.5	8.70	33.8	7.21	30.0	5.97	26.3	4.93	22.5	4.04	18.8	3.26	15.0	2.53	11.3	1.81
9.0	7.9	37.5		37.5	9.15	33.8	7.54	30.0	6.21	26.3	5.11	22.5	4.17	18.8	3.36	15.0	2.61	11.3	1.87
7.0	6.0	37.5		37.5	9.65	33.8	7.91	30.0	6.48	26.3	5.30	22.5	4.31	18.8	3.46	15.0	2.68	11.3	1.93
5.0	4.1	36.2		36.2	9.58	32.5	7.85	28.9	6.43	25.3	5.26	21.7	4.28	18.1	3.43	14.5	2.66	10.8	1.91
3.0	2.2	34.8		34.8	9.50	31.3	7.79	27.9	6.38	24.4	5.22	20.9	4.25	17.4	3.41	13.9	2.64	10.4	1.90
0.0	-0.7	32.8		32.8	9.39	29.5	7.70	26.2	6.31	22.9	5.16	19.7	4.20	16.4	3.37	13.1	2.61	9.8	1.88
-3.0	-3.7	30.6		30.6	9.27	27.6	7.60	24.5	6.23	21.5	5.09	18.4	4.15	15.3	3.33	12.3	2.58	9.2	1.85
-5.0	-5.6	29.3		29.3	9.20	26.4	7.54	23.4	6.18	20.5	5.05	17.6	4.11	14.7	3.30	11.7	2.56	8.8	1.84
-7.0	-7.6	27.9		27.9	9.12	25.1	7.48	22.3	6.13	19.5	5.01	16.7	4.08	13.9	3.27	11.2	2.54	8.4	1.82
-10	-10.5	25.8		25.8	9.01	23.3	7.39	20.7	6.05	18.1	4.95	15.5	4.03	12.9	3.23	10.3	2.51	7.8	1.80
-14.5	-15.0	22.7		22.7	8.84	20.4	7.25	18.1	5.94	15.9	4.85	13.6	3.95	11.3	3.17	9.1	2.46	6.8	1.77

TC : Total Capacity PI : Power Input
Indoor air temperature conditions : 20.0°C dry-bulb



MMY-MAP1406HT8P-E (14HP, 40kW system)

Cooling			Compressor + Outdoor Fan Power consumption (kW)														
Outdoor Unit Dry-Bulb (°C)	Outdoor Unit 100% Cooling Capacity (kW)	100% Capacity		90% Capacity		80% Capacity		70% Capacity		60% Capacity		50% Capacity		40% Capacity		30% Capacity	
		TC	PI	TC	PI	TC	PI	TC	PI	TC	PI	TC	PI	TC	PI	TC	PI
		(kW)	(kW)	(kW)	(kW)	(kW)	(kW)	(kW)	(kW)	(kW)	(kW)	(kW)	(kW)	(kW)	(kW)	(kW)	(kW)
40 °C	37.2	37.2	13.3	33.5	10.5	29.8	8.21	26.1	6.40	22.3	4.95	18.6	3.79	14.9	2.82	11.2	1.95
39 °C	37.8	37.8	13.1	34.0	10.3	30.3	8.08	26.5	6.30	22.7	4.88	18.9	3.74	15.1	2.78	11.3	1.92
37 °C	39.0	39.0	12.7	35.1	10.0	31.2	7.84	27.3	6.11	23.4	4.73	19.5	3.62	15.6	2.69	11.7	1.86
35 °C	40.0	40.0	12.3	36.0	9.69	32.0	7.59	28.0	5.92	24.0	4.58	20.0	3.51	16.0	2.61	12.0	1.81
33 °C	40.0	40.0	11.3	36.0	8.91	32.0	7.01	28.0	5.49	24.0	4.27	20.0	3.28	16.0	2.45	12.0	1.69
31 °C	40.0	40.0	10.3	36.0	8.22	32.0	6.50	28.0	5.11	24.0	3.99	20.0	3.08	16.0	2.30	12.0	1.59
30 °C	40.0	40.0	9.94	36.0	7.91	32.0	6.26	28.0	4.94	24.0	3.86	20.0	2.98	16.0	2.23	12.0	1.54
29 °C	40.0	40.0	9.55	36.0	7.62	32.0	6.04	28.0	4.77	24.0	3.74	20.0	2.89	16.0	2.16	12.0	1.49
27 °C	40.0	40.0	8.85	36.0	7.08	32.0	5.63	28.0	4.46	24.0	3.51	20.0	2.72	16.0	2.04	12.0	1.40
25 °C	40.0	40.0	8.22	36.0	6.59	32.0	5.26	28.0	4.18	24.0	3.30	20.0	2.56	16.0	1.92	12.0	1.32
23 °C	40.0	40.0	7.81	36.0	6.28	32.0	5.02	28.0	4.00	24.0	3.16	20.0	2.46	16.0	1.85	12.0	1.27
21 °C	40.0	40.0	7.62	36.0	6.13	32.0	4.92	28.0	3.93	24.0	3.11	20.0	2.42	16.0	1.82	12.0	1.25
20 °C	40.0	40.0	7.53	36.0	6.07	32.0	4.87	28.0	3.89	24.0	3.09	20.0	2.41	16.0	1.81	12.0	1.24
19 °C	40.0	40.0	7.45	36.0	6.01	32.0	4.83	28.0	3.86	24.0	3.06	20.0	2.39	16.0	1.79	12.0	1.23
17 °C	40.0	40.0	7.31	36.0	5.90	32.0	4.75	28.0	3.81	24.0	3.02	20.0	2.36	16.0	1.77	12.0	1.22
15 °C	40.0	40.0	7.18	36.0	5.81	32.0	4.69	28.0	3.76	24.0	2.99	20.0	2.34	16.0	1.76	12.0	1.20

TC : Total Capacity PI : Power Input
Indoor air temperature conditions : 27.0°C dry-bulb / 19.0°C wet bulb

Heating			Compressor + Outdoor Fan Power consumption (kW)															
Outdoor Unit Dry-Bulb (°C)	Outdoor Unit Wet-Bulb (°C)	Outdoor Unit 100% Heating Capacity (kW)	100% Capacity		90% Capacity		80% Capacity		70% Capacity		60% Capacity		50% Capacity		40% Capacity		30% Capacity	
			TC	PI	TC	PI	TC	PI	TC	PI	TC	PI	TC	PI	TC	PI	TC	PI
			(kW)	(kW)	(kW)	(kW)	(kW)	(kW)	(kW)	(kW)	(kW)	(kW)	(kW)	(kW)	(kW)	(kW)	(kW)	(kW)
15.0	13.7	45.0	45.0	9.05	40.5	7.48	36.0	6.19	31.5	5.13	27.0	4.26	22.5	3.53	18.0	2.89	13.5	2.31
13.0	11.8	45.0	45.0	9.50	40.5	7.81	36.0	6.43	31.5	5.30	27.0	4.37	22.5	3.61	18.0	2.95	13.5	2.35
11.0	9.8	45.0	45.0	10.0	40.5	8.19	36.0	6.70	31.5	5.49	27.0	4.51	22.5	3.70	18.0	3.01	13.5	2.39
9.0	7.9	45.0	45.0	10.6	40.5	8.60	36.0	6.99	31.5	5.69	27.0	4.65	22.5	3.79	18.0	3.07	13.5	2.43
7.0	6.0	45.0	45.0	11.2	40.5	9.06	36.0	7.32	31.5	5.92	27.0	4.80	22.5	3.90	18.0	3.14	13.5	2.48
5.0	4.1	43.6	43.6	11.1	39.2	9.00	34.8	7.27	30.5	5.88	26.1	4.77	21.8	3.87	17.4	3.13	13.1	2.47
3.0	2.2	42.1	42.1	11.1	37.9	8.95	33.7	7.23	29.5	5.85	25.3	4.74	21.1	3.85	16.8	3.11	12.6	2.45
0.0	-0.7	39.9	39.9	11.0	35.9	8.87	31.9	7.17	27.9	5.80	23.9	4.70	19.9	3.82	16.0	3.08	12.0	2.43
-3.0	-3.7	37.6	37.6	10.9	33.8	8.79	30.1	7.10	26.3	5.75	22.6	4.66	18.8	3.78	15.0	3.05	11.3	2.41
-5.0	-5.6	36.2	36.2	10.8	32.5	8.74	28.9	7.06	25.3	5.71	21.7	4.63	18.1	3.76	14.5	3.03	10.8	2.39
-7.0	-7.6	34.6	34.6	10.7	31.2	8.68	27.7	7.02	24.2	5.68	20.8	4.60	17.3	3.74	13.9	3.02	10.4	2.38
-10	-10.5	32.4	32.4	10.6	29.2	8.61	25.9	6.95	22.7	5.63	19.5	4.56	16.2	3.70	13.0	2.99	9.7	2.36
-14.5	-15.0	29.0	29.0	10.5	26.1	8.48	23.2	6.85	20.3	5.55	17.4	4.50	14.5	3.65	11.6	2.95	8.7	2.32

TC : Total Capacity PI : Power Input
Indoor air temperature conditions : 20.0°C dry-bulb



MMY-MAP1606HT8P-E (16HP, 45kW system)

Outdoor Unit Dry-Bulb (°C)		Outdoor Unit 100% Cooling Capacity (kW)	Compressor + Outdoor Fan Power consumption (kW)															
			100% Capacity		90% Capacity		80% Capacity		70% Capacity		60% Capacity		50% Capacity		40% Capacity		30% Capacity	
			TC (kW)	PI (kW)	TC (kW)	PI (kW)	TC (kW)	PI (kW)	TC (kW)	PI (kW)	TC (kW)	PI (kW)	TC (kW)	PI (kW)	TC (kW)	PI (kW)	TC (kW)	PI (kW)
40 °C	41.9	41.9	15.4	37.7	12.3	33.5	9.70	29.3	7.54	25.1	5.77	20.9	4.31	16.8	3.10	12.6	2.08	
39 °C	42.6	42.6	15.2	38.3	12.1	34.0	9.56	29.8	7.43	25.5	5.68	21.3	4.25	17.0	3.06	12.8	2.05	
37 °C	43.8	43.8	14.8	39.4	11.8	35.1	9.27	30.7	7.20	26.3	5.51	21.9	4.12	17.5	2.96	13.1	1.98	
35 °C	45.0	45.0	14.3	40.5	11.4	36.0	8.97	31.5	6.98	27.0	5.34	22.5	3.99	18.0	2.87	13.5	1.92	
33 °C	45.0	45.0	13.1	40.5	10.5	36.0	8.29	31.5	6.47	27.0	4.96	22.5	3.72	18.0	2.68	13.5	1.80	
31 °C	45.0	45.0	12.1	40.5	9.69	36.0	7.68	31.5	6.01	27.0	4.63	22.5	3.48	18.0	2.51	13.5	1.68	
30 °C	45.0	45.0	11.6	40.5	9.33	36.0	7.40	31.5	5.80	27.0	4.47	22.5	3.37	18.0	2.44	13.5	1.63	
29 °C	45.0	45.0	11.2	40.5	8.99	36.0	7.14	31.5	5.60	27.0	4.32	22.5	3.26	18.0	2.36	13.5	1.58	
27 °C	45.0	45.0	10.4	40.5	8.36	36.0	6.65	31.5	5.23	27.0	4.05	22.5	3.06	18.0	2.22	13.5	1.49	
25 °C	45.0	45.0	9.65	40.5	7.78	36.0	6.21	31.5	4.89	27.0	3.79	22.5	2.87	18.0	2.08	13.5	1.40	
23 °C	45.0	45.0	9.19	40.5	7.42	36.0	5.93	31.5	4.68	27.0	3.63	22.5	2.75	18.0	2.00	13.5	1.34	
21 °C	45.0	45.0	8.96	40.5	7.25	36.0	5.80	31.5	4.59	27.0	3.57	22.5	2.71	18.0	1.97	13.5	1.32	
20 °C	45.0	45.0	8.86	40.5	7.17	36.0	5.75	31.5	4.54	27.0	3.54	22.5	2.68	18.0	1.95	13.5	1.31	
19 °C	45.0	45.0	8.77	40.5	7.10	36.0	5.69	31.5	4.51	27.0	3.51	22.5	2.66	18.0	1.94	13.5	1.30	
17 °C	45.0	45.0	8.61	40.5	6.98	36.0	5.60	31.5	4.44	27.0	3.46	22.5	2.63	18.0	1.92	13.5	1.28	
15 °C	45.0	45.0	8.47	40.5	6.87	36.0	5.52	31.5	4.38	27.0	3.42	22.5	2.60	18.0	1.89	13.5	1.27	

TC : Total Capacity PI : Power Input
Indoor air temperature conditions : 27.0°C dry-bulb / 19.0°C wet bulb

Outdoor Unit Dry-Bulb (°C)			Outdoor Unit 100% Heating Capacity (kW)	Compressor + Outdoor Fan Power consumption (kW)															
				100% Capacity		90% Capacity		80% Capacity		70% Capacity		60% Capacity		50% Capacity		40% Capacity		30% Capacity	
				TC (kW)	PI (kW)	TC (kW)	PI (kW)	TC (kW)	PI (kW)	TC (kW)	PI (kW)	TC (kW)	PI (kW)	TC (kW)	PI (kW)	TC (kW)	PI (kW)	TC (kW)	PI (kW)
15.0	13.7	50.0	50.0	10.6	45.0	8.83	40.0	7.32	35.0	6.03	30.0	4.95	25.0	4.03	20.0	3.26	15.0	2.61	
13.0	11.8	50.0	50.0	11.1	45.0	9.21	40.0	7.60	35.0	6.24	30.0	5.09	25.0	4.13	20.0	3.33	15.0	2.65	
11.0	9.8	50.0	50.0	11.7	45.0	9.64	40.0	7.93	35.0	6.48	30.0	5.26	25.0	4.25	20.0	3.41	15.0	2.70	
9.0	7.9	50.0	50.0	12.2	45.0	10.1	40.0	8.27	35.0	6.73	30.0	5.44	25.0	4.37	20.0	3.48	15.0	2.75	
7.0	6.0	50.0	50.0	12.9	45.0	10.6	40.0	8.64	35.0	7.00	30.0	5.63	25.0	4.50	20.0	3.57	15.0	2.80	
5.0	4.1	48.2	48.2	12.8	43.4	10.5	38.6	8.58	33.7	6.95	28.9	5.59	24.1	4.47	19.3	3.54	14.5	2.78	
3.0	2.2	46.4	46.4	12.7	41.8	10.4	37.1	8.51	32.5	6.89	27.9	5.55	23.2	4.43	18.6	3.51	13.9	2.76	
0.0	-0.7	43.7	43.7	12.6	39.3	10.3	34.9	8.41	30.6	6.81	26.2	5.48	21.8	4.38	17.5	3.47	13.1	2.72	
-3.0	-3.7	40.9	40.9	12.4	36.8	10.2	32.7	8.31	28.6	6.73	24.5	5.41	20.4	4.33	16.3	3.43	12.3	2.69	
-5.0	-5.6	39.1	39.1	12.3	35.2	10.1	31.3	8.24	27.3	6.67	23.4	5.37	19.5	4.29	15.6	3.40	11.7	2.67	
-7.0	-7.6	37.2	37.2	12.2	33.5	10.0	29.7	8.17	26.0	6.62	22.3	5.32	18.6	4.25	14.9	3.37	11.2	2.65	
-10	-10.5	34.5	34.5	12.0	31.0	9.90	27.6	8.07	24.1	6.54	20.7	5.26	17.2	4.20	13.8	3.33	10.3	2.61	
-14.5	-15.0	30.2	30.2	11.8	27.2	9.71	24.2	7.92	21.1	6.41	18.1	5.16	15.1	4.12	12.1	3.27	9.06	2.56	

TC : Total Capacity PI : Power Input
Indoor air temperature conditions : 20.0°C dry-bulb



MMY-MAP1806HT8P-E (18HP, 50.4kW system)

Cooling		Compressor + Outdoor Fan Power consumption (kW)																	
		Outdoor Unit		100% Capacity		90% Capacity		80% Capacity		70% Capacity		60% Capacity		50% Capacity		40% Capacity		30% Capacity	
		Dry-Bulb (°C)	100% Cooling Capacity (kW)	TC (kW)	PI (kW)	TC (kW)	PI (kW)	TC (kW)	PI (kW)	TC (kW)	PI (kW)	TC (kW)	PI (kW)	TC (kW)	PI (kW)	TC (kW)	PI (kW)	TC (kW)	PI (kW)
40 °C	46.9	46.9	15.8	42.2	12.8	37.5	10.26	32.8	8.17	28.1	6.42	23.5	4.95	18.8	3.69	14.1	2.54		
39 °C	47.7	47.7	15.5	42.9	12.6	38.1	10.11	33.4	8.05	28.6	6.33	23.8	4.88	19.1	3.63	14.3	2.51		
37 °C	49.1	49.1	15.1	44.2	12.2	39.3	9.80	34.4	7.80	29.4	6.14	24.5	4.73	19.6	3.52	14.7	2.43		
35 °C	50.4	50.4	14.6	45.4	11.8	40.3	9.49	35.3	7.56	30.2	5.94	25.2	4.58	20.2	3.41	15.1	2.35		
33 °C	50.4	50.4	13.4	45.4	10.9	40.3	8.80	35.3	7.03	30.2	5.55	25.2	4.29	20.2	3.20	15.1	2.21		
31 °C	50.4	50.4	12.4	45.4	10.1	40.3	8.19	35.3	6.56	30.2	5.19	25.2	4.03	20.2	3.00	15.1	2.07		
30 °C	50.4	50.4	12.0	45.4	9.76	40.3	7.91	35.3	6.35	30.2	5.03	25.2	3.90	20.2	2.91	15.1	2.01		
29 °C	50.4	50.4	11.5	45.4	9.42	40.3	7.64	35.3	6.14	30.2	4.87	25.2	3.78	20.2	2.83	15.1	1.95		
27 °C	50.4	50.4	10.7	45.4	8.78	40.3	7.14	35.3	5.75	30.2	4.57	25.2	3.56	20.2	2.66	15.1	1.83		
25 °C	50.4	50.4	10.0	45.4	8.20	40.3	6.68	35.3	5.39	30.2	4.30	25.2	3.35	20.2	2.50	15.1	1.72		
23 °C	50.4	50.4	9.53	45.4	7.84	40.3	6.39	35.3	5.17	30.2	4.13	25.2	3.22	20.2	2.41	15.1	1.66		
21 °C	50.4	50.4	9.32	45.4	7.67	40.3	6.27	35.3	5.08	30.2	4.06	25.2	3.17	20.2	2.37	15.1	1.63		
20 °C	50.4	50.4	9.22	45.4	7.60	40.3	6.22	35.3	5.04	30.2	4.03	25.2	3.15	20.2	2.36	15.1	1.62		
19 °C	50.4	50.4	9.13	45.4	7.53	40.3	6.16	35.3	5.00	30.2	4.00	25.2	3.12	20.2	2.34	15.1	1.61		
17 °C	50.4	50.4	8.98	45.4	7.41	40.3	6.07	35.3	4.93	30.2	3.95	25.2	3.09	20.2	2.31	15.1	1.59		
15 °C	50.4	50.4	8.84	45.4	7.31	40.3	6.00	35.3	4.87	30.2	3.90	25.2	3.06	20.2	2.29	15.1	1.57		

TC : Total Capacity PI : Power Input
 Indoor air temperature conditions : 27.0°C dry-bulb / 19.0°C wet bulb

Heating			Compressor + Outdoor Fan Power consumption (kW)																	
			Outdoor Unit		100% Capacity		90% Capacity		80% Capacity		70% Capacity		60% Capacity		50% Capacity		40% Capacity		30% Capacity	
			Dry-Bulb (°C)	Wet-Bulb (°C)	Heating Capacity (kW)	TC (kW)	PI (kW)	TC (kW)	PI (kW)	TC (kW)	PI (kW)	TC (kW)	PI (kW)	TC (kW)	PI (kW)	TC (kW)	PI (kW)	TC (kW)	PI (kW)	
15.0	13.7	56.0	56.0	11.7	50.4	9.90	44.8	8.31	39.2	6.92	33.6	5.69	28.0	4.60	22.4	3.60	16.8	2.65		
13.0	11.8	56.0	56.0	12.2	50.4	10.3	44.8	8.61	39.2	7.14	33.6	5.86	28.0	4.73	22.4	3.69	16.8	2.72		
11.0	9.8	56.0	56.0	12.8	50.4	10.7	44.8	8.95	39.2	7.40	33.6	6.06	28.0	4.87	22.4	3.80	16.8	2.80		
9.0	7.9	56.0	56.0	13.4	50.4	11.2	44.8	9.30	39.2	7.67	33.6	6.25	28.0	5.02	22.4	3.90	16.8	2.87		
7.0	6.0	56.0	56.0	14.1	50.4	11.7	44.8	9.69	39.2	7.96	33.6	6.47	28.0	5.17	22.4	4.02	16.8	2.95		
5.0	4.1	54.2	54.2	14.0	48.8	11.7	43.4	9.64	37.9	7.91	32.5	6.43	27.1	5.14	21.7	3.99	16.3	2.93		
3.0	2.2	52.4	52.4	13.9	47.2	11.6	41.9	9.58	36.7	7.87	31.4	6.39	26.2	5.11	21.0	3.97	15.7	2.92		
0.0	-0.7	49.6	49.6	13.8	44.7	11.5	39.7	9.50	34.8	7.80	29.8	6.34	24.8	5.07	19.9	3.93	14.9	2.89		
-3.0	-3.7	46.8	46.8	13.7	42.1	11.4	37.4	9.41	32.8	7.73	28.1	6.28	23.4	5.02	18.7	3.90	14.0	2.86		
-5.0	-5.6	45.0	45.0	13.6	40.5	11.3	36.0	9.35	31.5	7.68	27.0	6.24	22.5	4.99	18.0	3.88	13.5	2.85		
-7.0	-7.6	43.1	43.1	13.5	38.8	11.2	34.5	9.30	30.2	7.63	25.9	6.20	21.6	4.96	17.2	3.85	12.9	2.83		
-10	-10.5	40.4	40.4	13.4	36.3	11.1	32.3	9.21	28.3	7.56	24.2	6.15	20.2	4.92	16.1	3.82	12.1	2.80		
-14.5	-15.0	36.1	36.1	13.2	32.5	11.0	28.9	9.08	25.3	7.46	21.7	6.06	18.0	4.85	14.4	3.76	10.8	2.76		

TC : Total Capacity PI : Power Input
 Indoor air temperature conditions : 20.0°C dry-bulb



MMY-MAP2006HT8P-E (20HP, 56.0kW system)

Outdoor Unit Dry-Bulb (°C)		Outdoor Unit 100% Cooling Capacity (kW)	Compressor + Outdoor Fan Power consumption (kW)															
			100% Capacity		90% Capacity		80% Capacity		70% Capacity		60% Capacity		50% Capacity		40% Capacity		30% Capacity	
			TC	PI	TC	PI	TC	PI	TC	PI	TC	PI	TC	PI	TC	PI	TC	PI
			(kW)	(kW)	(kW)	(kW)	(kW)	(kW)	(kW)	(kW)	(kW)	(kW)	(kW)	(kW)	(kW)	(kW)	(kW)	(kW)
40 °C	52.1	52.1	18.7	46.9	15.1	41.7	12.0	36.5	9.49	31.3	7.39	26.1	5.63	20.8	4.13	15.6	2.80	
39 °C	53.0	53.0	18.4	47.7	14.8	42.4	11.8	37.1	9.35	31.8	7.28	26.5	5.54	21.2	4.07	15.9	2.76	
37 °C	54.5	54.5	17.9	49.1	14.4	43.6	11.5	38.2	9.06	32.7	7.06	27.3	5.38	21.8	3.94	16.4	2.68	
35 °C	56.0	56.0	17.3	50.4	13.9	44.8	11.1	39.2	8.78	33.6	6.83	28.0	5.21	22.4	3.82	16.8	2.59	
33 °C	56.0	56.0	15.9	50.4	12.9	44.8	10.3	39.2	8.16	33.6	6.37	28.0	4.87	22.4	3.58	16.8	2.43	
31 °C	56.0	56.0	14.7	50.4	11.9	44.8	9.56	39.2	7.60	33.6	5.95	28.0	4.56	22.4	3.36	16.8	2.28	
30 °C	56.0	56.0	14.1	50.4	11.5	44.8	9.23	39.2	7.34	33.6	5.76	28.0	4.42	22.4	3.25	16.8	2.20	
29 °C	56.0	56.0	13.6	50.4	11.1	44.8	8.91	39.2	7.10	33.6	5.57	28.0	4.28	22.4	3.15	16.8	2.14	
27 °C	56.0	56.0	12.7	50.4	10.3	44.8	8.32	39.2	6.64	33.6	5.23	28.0	4.02	22.4	2.96	16.8	2.01	
25 °C	56.0	56.0	11.8	50.4	9.62	44.8	7.78	39.2	6.22	33.6	4.91	28.0	3.78	22.4	2.79	16.8	1.89	
23 °C	56.0	56.0	11.2	50.4	9.18	44.8	7.44	39.2	5.96	33.6	4.71	28.0	3.63	22.4	2.68	16.8	1.81	
21 °C	56.0	56.0	11.0	50.4	8.98	44.8	7.29	39.2	5.85	33.6	4.63	28.0	3.57	22.4	2.64	16.8	1.78	
20 °C	56.0	56.0	10.9	50.4	8.89	44.8	7.22	39.2	5.80	33.6	4.59	28.0	3.54	22.4	2.62	16.8	1.77	
19 °C	56.0	56.0	10.8	50.4	8.81	44.8	7.16	39.2	5.76	33.6	4.56	28.0	3.52	22.4	2.60	16.8	1.76	
17 °C	56.0	56.0	10.6	50.4	8.67	44.8	7.05	39.2	5.67	33.6	4.50	28.0	3.48	22.4	2.57	16.8	1.74	
15 °C	56.0	56.0	10.4	50.4	8.54	44.8	6.96	39.2	5.60	33.6	4.44	28.0	3.44	22.4	2.54	16.8	1.72	

TC : Total Capacity PI : Power Input
Indoor air temperature conditions : 27.0°C dry-bulb / 19.0°C wet bulb

Outdoor Unit Dry-Bulb (°C)		Outdoor Unit 100% Heating Capacity (kW)	Wet-Bulb (°C)	Compressor + Outdoor Fan Power consumption (kW)															
				100% Capacity		90% Capacity		80% Capacity		70% Capacity		60% Capacity		50% Capacity		40% Capacity		30% Capacity	
				TC	PI	TC	PI	TC	PI	TC	PI	TC	PI	TC	PI	TC	PI	TC	PI
				(kW)	(kW)	(kW)	(kW)	(kW)	(kW)	(kW)	(kW)	(kW)	(kW)	(kW)	(kW)	(kW)	(kW)	(kW)	(kW)
15.0	13.7	63.0	63.0	14.2	56.7	12.0	50.4	10.1	44.1	8.39	37.8	6.89	31.5	5.52	25.2	4.25	18.9	3.02	
13.0	11.8	63.0	63.0	14.8	56.7	12.5	50.4	10.4	44.1	8.66	37.8	7.10	31.5	5.68	25.2	4.37	18.9	3.11	
11.0	9.8	63.0	63.0	15.5	56.7	13.0	50.4	10.8	44.1	8.97	37.8	7.33	31.5	5.86	25.2	4.51	18.9	3.21	
9.0	7.9	63.0	63.0	16.2	56.7	13.5	50.4	11.3	44.1	9.30	37.8	7.58	31.5	6.05	25.2	4.64	18.9	3.30	
7.0	6.0	63.0	63.0	17.0	56.7	14.2	50.4	11.7	44.1	9.65	37.8	7.84	31.5	6.24	25.2	4.79	18.9	3.41	
5.0	4.1	60.7	60.7	16.9	54.7	14.1	48.6	11.6	42.5	9.58	36.4	7.78	30.4	6.19	24.3	4.75	18.2	3.38	
3.0	2.2	58.5	58.5	16.7	52.6	13.9	46.8	11.6	40.9	9.50	35.1	7.72	29.2	6.15	23.4	4.71	17.5	3.36	
0.0	-0.7	55.0	55.0	16.5	49.5	13.8	44.0	11.4	38.5	9.39	33.0	7.63	27.5	6.07	22.0	4.66	16.5	3.32	
-3.0	-3.7	51.5	51.5	16.3	46.3	13.6	41.2	11.3	36.0	9.27	30.9	7.54	25.7	6.00	20.6	4.60	15.4	3.28	
-5.0	-5.6	49.2	49.2	16.2	44.3	13.5	39.4	11.2	34.5	9.20	29.5	7.48	24.6	5.95	19.7	4.56	14.8	3.25	
-7.0	-7.6	46.9	46.9	16.1	42.2	13.4	37.5	11.1	32.8	9.12	28.1	7.41	23.4	5.90	18.7	4.53	14.1	3.23	
-10	-10.5	43.4	43.4	15.9	39.1	13.2	34.7	11.0	30.4	9.01	26.0	7.32	21.7	5.83	17.4	4.47	13.0	3.19	
-14.5	-15.0	38.1	38.1	15.6	34.3	13.0	30.5	10.7	26.6	8.84	22.8	7.18	19.0	5.72	15.2	4.38	11.4	3.12	

TC : Total Capacity PI : Power Input
Indoor air temperature conditions : 20.0°C dry-bulb



MMY-MAP2206HT8P-E (22HP, 61.5kW system)

Cooling

Outdoor Unit (°C)	Outdoor Unit 100% Capacity (kW)	Compressor + Outdoor Fan Power consumption (kW)															
		100%		90%		80%		70%		60%		50%		40%		30%	
		TC (kW)	PI (kW)	TC (kW)	PI (kW)	TC (kW)	PI (kW)	TC (kW)	PI (kW)	TC (kW)	PI (kW)	TC (kW)	PI (kW)	TC (kW)	PI (kW)	TC (kW)	PI (kW)
40 °C	57.2	57.2	25.1	51.5	19.7	45.8	15.2	40.1	11.6	34.3	8.59	28.6	6.22	22.9	4.36	17.2	2.91
39 °C	58.2	58.2	24.7	52.3	19.4	46.5	15.0	40.7	11.4	34.9	8.46	29.1	6.13	23.3	4.30	17.4	2.87
37 °C	59.9	59.9	23.9	53.9	18.8	47.9	14.6	41.9	11.0	35.9	8.20	29.9	5.94	24.0	4.17	18.0	2.78
35 °C	61.5	61.5	23.2	55.3	18.2	49.2	14.1	43.0	10.7	36.9	7.95	30.7	5.75	24.6	4.03	18.4	2.69
33 °C	61.5	61.5	21.2	55.4	16.7	49.2	13.0	43.1	9.87	36.9	7.36	30.8	5.35	24.6	3.76	18.5	2.52
31 °C	61.5	61.5	19.5	55.4	15.4	49.2	12.0	43.1	9.14	36.9	6.83	30.8	4.99	24.6	3.52	18.5	2.37
30 °C	61.5	61.5	18.7	55.4	14.8	49.2	11.5	43.1	8.80	36.9	6.59	30.8	4.82	24.6	3.41	18.5	2.30
29 °C	61.5	61.5	18.0	55.4	14.2	49.2	11.1	43.1	8.48	36.9	6.36	30.8	4.66	24.6	3.30	18.5	2.23
27 °C	61.5	61.5	16.7	55.4	13.2	49.2	10.3	43.1	7.90	36.9	5.94	30.8	4.36	24.6	3.10	18.5	2.10
25 °C	61.5	61.5	15.5	55.4	12.3	49.2	9.59	43.1	7.36	36.9	5.55	30.8	4.08	24.6	2.91	18.5	1.97
23 °C	61.5	61.5	14.7	55.4	11.7	49.2	9.13	43.1	7.03	36.9	5.31	30.8	3.91	24.6	2.79	18.5	1.90
21 °C	61.5	61.5	14.3	55.4	11.4	49.2	8.92	43.1	6.87	36.9	5.20	30.8	3.84	24.6	2.75	18.5	1.87
20 °C	61.5	61.5	14.1	55.4	11.2	49.2	8.82	43.1	6.80	36.9	5.15	30.8	3.81	24.6	2.73	18.5	1.86
19 °C	61.5	61.5	14.0	55.4	11.1	49.2	8.73	43.1	6.74	36.9	5.10	30.8	3.78	24.6	2.71	18.5	1.85
17 °C	61.5	61.5	13.7	55.4	10.9	49.2	8.57	43.1	6.62	36.9	5.02	30.8	3.72	24.6	2.67	18.5	1.83
15 °C	61.5	61.5	13.5	55.4	10.7	49.2	8.44	43.1	6.53	36.9	4.96	30.8	3.68	24.6	2.64	18.5	1.81

TC : Total Capacity PI : Power Input
Indoor air temperature conditions : 27.0°C dry-bulb / 19.0°C wet bulb

Heating

Outdoor Unit Dry-Bulb (°C) / Wet-Bulb (°C)		Outdoor Unit 100% Heating Capacity (kW)	Compressor + Outdoor Fan Power consumption (kW)															
			100%		90%		80%		70%		60%		50%		40%		30%	
			TC (kW)	PI (kW)	TC (kW)	PI (kW)	TC (kW)	PI (kW)	TC (kW)	PI (kW)	TC (kW)	PI (kW)	TC (kW)	PI (kW)	TC (kW)	PI (kW)	TC (kW)	PI (kW)
15.0	13.7	64.0	64.0	15.6	57.6	13.2	51.2	11.1	44.8	9.26	38.4	7.64	32.0	6.17	25.6	4.77	19.2	3.37
13.0	11.8	64.0	64.0	16.3	57.6	13.7	51.2	11.5	44.8	9.55	38.4	7.87	32.0	6.34	25.6	4.90	19.2	3.48
11.0	9.8	64.0	64.0	17.1	57.6	14.3	51.2	11.9	44.8	9.89	38.4	8.12	32.0	6.53	25.6	5.05	19.2	3.59
9.0	7.9	64.0	64.0	17.9	57.6	14.9	51.2	12.4	44.8	10.24	38.4	8.38	32.0	6.73	25.6	5.20	19.2	3.70
7.0	6.0	64.0	64.0	18.8	57.6	15.6	51.2	12.9	44.8	10.62	38.4	8.66	32.0	6.94	25.6	5.36	19.2	3.82
5.0	4.1	61.7	61.7	18.7	55.5	15.5	49.4	12.8	43.2	10.54	37.0	8.60	30.9	6.89	24.7	5.32	18.5	3.79
3.0	2.2	59.4	59.4	18.5	53.5	15.4	47.5	12.7	41.6	10.46	35.6	8.53	29.7	6.84	23.8	5.28	17.8	3.77
0.0	-0.7	55.9	55.9	18.3	50.3	15.2	44.7	12.6	39.1	10.34	33.6	8.43	28.0	6.75	22.4	5.21	16.8	3.72
-3.0	-3.7	52.3	52.3	18.1	47.1	15.0	41.8	12.4	36.6	10.21	31.4	8.33	26.1	6.67	20.9	5.15	15.7	3.68
-5.0	-5.6	50.0	50.0	17.9	45.0	14.9	40.0	12.3	35.0	10.13	30.0	8.26	25.0	6.62	20.0	5.11	15.0	3.65
-7.0	-7.6	47.6	47.6	17.8	42.8	14.7	38.1	12.2	33.3	10.04	28.6	8.19	23.8	6.56	19.0	5.07	14.3	3.62
-10	-10.5	44.1	44.1	17.6	39.7	14.6	35.3	12.0	30.9	9.92	26.5	8.09	22.0	6.48	17.6	5.00	13.2	3.57
-14.5	-15.0	38.7	38.7	17.2	34.8	14.3	30.9	11.8	27.1	9.73	23.2	7.94	19.3	6.36	15.5	4.91	11.6	3.50

TC : Total Capacity PI : Power Input
Indoor air temperature conditions : 20.0°C dry-bulb



MMY-AP2416HT8P-E (24HP, 67kW system)

Cooling		Compressor + Outdoor Fan Power consumption (kW)																	
		Outdoor Unit		100%		90%		80%		70%		60%		50%		40%		30%	
		(°C)	Capacity (kW)	TC (kW)	PI (kW)	TC (kW)	PI (kW)	TC (kW)	PI (kW)	TC (kW)	PI (kW)	TC (kW)	PI (kW)	TC (kW)	PI (kW)	TC (kW)	PI (kW)	TC (kW)	PI (kW)
40 °C	62.4	62.4	21.6	56.1	17.3	49.9	13.7	43.6	10.7	37.4	8.22	31.2	6.17	24.9	4.49	18.7	3.07		
39 °C	63.4	63.4	21.3	57.0	17.1	50.7	13.5	44.3	10.5	38.0	8.09	31.7	6.08	25.3	4.42	19.0	3.03		
37 °C	65.2	65.2	20.6	58.7	16.5	52.2	13.1	45.7	10.2	39.1	7.85	32.6	5.90	26.1	4.29	19.6	2.94		
35 °C	67.0	67.0	20.0	60.3	16.0	53.6	12.7	46.9	9.90	40.2	7.60	33.5	5.71	26.8	4.15	20.1	2.84		
33 °C	67.0	67.0	18.4	60.3	14.8	53.6	11.7	46.9	9.18	40.2	7.07	33.5	5.33	26.8	3.89	20.1	2.67		
31 °C	67.0	67.0	17.0	60.3	13.7	53.6	10.9	46.9	8.54	40.2	6.60	33.5	4.99	26.8	3.65	20.1	2.51		
30 °C	67.0	67.0	16.3	60.3	13.1	53.6	10.5	46.9	8.24	40.2	6.38	33.5	4.83	26.8	3.53	20.1	2.43		
29 °C	67.0	67.0	15.7	60.3	12.7	53.6	10.1	46.9	7.96	40.2	6.17	33.5	4.68	26.8	3.43	20.1	2.36		
27 °C	67.0	67.0	14.6	60.3	11.8	53.6	9.42	46.9	7.44	40.2	5.78	33.5	4.39	26.8	3.22	20.1	2.22		
25 °C	67.0	67.0	13.6	60.3	11.0	53.6	8.80	46.9	6.96	40.2	5.42	33.5	4.12	26.8	3.03	20.1	2.09		
23 °C	67.0	67.0	12.9	60.3	10.5	53.6	8.41	46.9	6.66	40.2	5.19	33.5	3.96	26.8	2.92	20.1	2.01		
21 °C	67.0	67.0	12.6	60.3	10.2	53.6	8.23	46.9	6.53	40.2	5.10	33.5	3.89	26.8	2.87	20.1	1.98		
20 °C	67.0	67.0	12.5	60.3	10.1	53.6	8.15	46.9	6.47	40.2	5.06	33.5	3.86	26.8	2.85	20.1	1.97		
19 °C	67.0	67.0	12.3	60.3	10.0	53.6	8.07	46.9	6.42	40.2	5.02	33.5	3.84	26.8	2.83	20.1	1.96		
17 °C	67.0	67.0	12.1	60.3	9.86	53.6	7.94	46.9	6.32	40.2	4.95	33.5	3.79	26.8	2.80	20.1	1.94		
15 °C	67.0	67.0	11.9	60.3	9.72	53.6	7.83	46.9	6.24	40.2	4.89	33.5	3.74	26.8	2.77	20.1	1.92		

TC : Total Capacity PI : Power Input
Indoor air temperature conditions : 27.0°C dry-bulb / 19.0°C wet bulb

Heating		Compressor + Outdoor Fan Power consumption (kW)																	
		Outdoor Unit		100%		90%		80%		70%		60%		50%		40%		30%	
		Dry-Bulb (°C)	Wet-Bulb (°C)	Capacity (kW)	TC (kW)	PI (kW)	Capacity (kW)	TC (kW)	PI (kW)	Capacity (kW)	TC (kW)	PI (kW)	Capacity (kW)	TC (kW)	PI (kW)	Capacity (kW)	TC (kW)	PI (kW)	Capacity (kW)
15.0	13.7	75.0	75.0	15.8	67.5	13.2	60.0	11.1	52.5	9.22	45.0	7.61	37.5	6.16	30.0	4.79	22.5	3.41	
13.0	11.8	75.0	75.0	16.6	67.5	13.8	60.0	11.5	52.5	9.51	45.0	7.83	37.5	6.33	30.0	4.92	22.5	3.51	
11.0	9.8	75.0	75.0	17.4	67.5	14.4	60.0	11.9	52.5	9.86	45.0	8.08	37.5	6.52	30.0	5.07	22.5	3.62	
9.0	7.9	75.0	75.0	18.3	67.5	15.1	60.0	12.4	52.5	10.2	45.0	8.34	37.5	6.71	30.0	5.21	22.5	3.74	
7.0	6.0	75.0	75.0	19.3	67.5	15.8	60.0	13.0	52.5	10.6	45.0	8.62	37.5	6.92	30.0	5.37	22.5	3.86	
5.0	4.1	72.3	72.3	19.2	65.1	15.7	57.9	12.9	50.6	10.5	43.4	8.56	36.2	6.87	28.9	5.33	21.7	3.83	
3.0	2.2	69.6	69.6	19.0	62.7	15.6	55.7	12.8	48.7	10.4	41.8	8.49	34.8	6.81	27.9	5.29	20.9	3.80	
0.0	-0.7	65.5	65.5	18.8	59.0	15.4	52.4	12.6	45.9	10.3	39.3	8.39	32.8	6.73	26.2	5.22	19.7	3.75	
-3.0	-3.7	61.3	61.3	18.5	55.2	15.2	49.0	12.5	42.9	10.2	36.8	8.29	30.6	6.65	24.5	5.16	18.4	3.71	
-5.0	-5.6	58.6	58.6	18.4	52.7	15.1	46.9	12.4	41.0	10.1	35.2	8.22	29.3	6.60	23.4	5.12	17.6	3.68	
-7.0	-7.6	55.8	55.8	18.2	50.2	15.0	44.6	12.3	39.0	10.0	33.5	8.16	27.9	6.54	22.3	5.08	16.7	3.65	
-10	-10.5	51.7	51.7	18.0	46.5	14.8	41.3	12.1	36.2	9.90	31.0	8.06	25.8	6.46	20.7	5.01	15.5	3.60	
-14.5	-15.0	45.3	45.3	17.7	40.8	14.5	36.3	11.9	31.7	9.71	27.2	7.90	22.7	6.34	18.1	4.92	13.6	3.53	

TC : Total Capacity PI : Power Input
Indoor air temperature conditions : 20.0°C dry-bulb



MMY-AP2616HT8P-E (26HP, 73.5kW system)

Cooling		Compressor + Outdoor Fan Power consumption (kW)																	
		Outdoor Unit		100%		90%		80%		70%		60%		50%		40%		30%	
		(°C)	Capacity (kW)	TC (kW)	PI (kW)	TC (kW)	PI (kW)	TC (kW)	PI (kW)	TC (kW)	PI (kW)	TC (kW)	PI (kW)	TC (kW)	PI (kW)	TC (kW)	PI (kW)	TC (kW)	PI (kW)
40 °C	68.4	68.4	24.1	61.6	19.1	54.7	15.1	47.9	11.7	41.0	9.06	34.2	6.88	27.4	5.06	20.5	3.49		
39 °C	69.5	69.5	23.7	62.6	18.8	55.6	14.8	48.7	11.6	41.7	8.93	34.8	6.78	27.8	4.99	20.9	3.44		
37 °C	71.6	71.6	23.0	64.4	18.3	57.3	14.4	50.1	11.2	42.9	8.66	35.8	6.57	28.6	4.84	21.5	3.33		
35 °C	73.5	73.5	22.3	66.1	17.7	58.8	13.9	51.4	10.9	44.1	8.38	36.7	6.36	29.4	4.69	22.0	3.23		
33 °C	73.5	73.5	20.4	66.2	16.3	58.8	12.9	51.5	10.1	44.1	7.81	36.8	5.95	29.4	4.39	22.1	3.03		
31 °C	73.5	73.5	18.8	66.2	15.0	58.8	11.9	51.5	9.38	44.1	7.29	36.8	5.57	29.4	4.12	22.1	2.84		
30 °C	73.5	73.5	18.1	66.2	14.5	58.8	11.5	51.5	9.06	44.1	7.05	36.8	5.40	29.4	4.00	22.1	2.76		
29 °C	73.5	73.5	17.4	66.2	13.9	58.8	11.1	51.5	8.75	44.1	6.83	36.8	5.23	29.4	3.88	22.1	2.67		
27 °C	73.5	73.5	16.1	66.2	13.0	58.8	10.3	51.5	8.18	44.1	6.40	36.8	4.91	29.4	3.65	22.1	2.52		
25 °C	73.5	73.5	15.0	66.2	12.1	58.8	9.66	51.5	7.66	44.1	6.00	36.8	4.62	29.4	3.43	22.1	2.37		
23 °C	73.5	73.5	14.3	66.2	11.5	58.8	9.23	51.5	7.33	44.1	5.76	36.8	4.44	29.4	3.30	22.1	2.28		
21 °C	73.5	73.5	13.9	66.2	11.3	58.8	9.03	51.5	7.19	44.1	5.66	36.8	4.37	29.4	3.25	22.1	2.24		
20 °C	73.5	73.5	13.8	66.2	11.1	58.8	8.95	51.5	7.13	44.1	5.61	36.8	4.34	29.4	3.23	22.1	2.23		
19 °C	73.5	73.5	13.6	66.2	11.0	58.8	8.87	51.5	7.07	44.1	5.57	36.8	4.31	29.4	3.21	22.1	2.21		
17 °C	73.5	73.5	13.4	66.2	10.8	58.8	8.72	51.5	6.97	44.1	5.50	36.8	4.25	29.4	3.17	22.1	2.18		
15 °C	73.5	73.5	13.1	66.2	10.7	58.8	8.60	51.5	6.88	44.1	5.43	36.8	4.21	29.4	3.14	22.1	2.16		

TC : Total Capacity PI : Power Input
 Indoor air temperature conditions : 27.0°C dry-bulb / 19.0°C wet bulb

Heating		Compressor + Outdoor Fan Power consumption (kW)																	
		Outdoor Unit		100%		90%		80%		70%		60%		50%		40%		30%	
		Dry-Bulb (°C)	Wet-Bulb (°C)	Capacity (kW)	TC (kW)	PI (kW)	Capacity (kW)	TC (kW)	PI (kW)	Capacity (kW)	TC (kW)	PI (kW)	Capacity (kW)	TC (kW)	PI (kW)	Capacity (kW)	TC (kW)	PI (kW)	Capacity (kW)
15.0	13.7	82.5	82.5	17.0	74.3	14.1	66.0	11.7	57.8	9.74	49.5	8.06	41.3	6.61	33.0	5.28	24.8	4.01	
13.0	11.8	82.5	82.5	17.8	74.3	14.7	66.0	12.2	57.8	10.1	49.5	8.29	41.3	6.77	33.0	5.41	24.8	4.10	
11.0	9.8	82.5	82.5	18.7	74.3	15.4	66.0	12.7	57.8	10.4	49.5	8.55	41.3	6.96	33.0	5.54	24.8	4.20	
9.0	7.9	82.5	82.5	19.7	74.3	16.1	66.0	13.2	57.8	10.8	49.5	8.82	41.3	7.15	33.0	5.68	24.8	4.30	
7.0	6.0	82.5	82.5	20.8	74.3	17.0	66.0	13.8	57.8	11.2	49.5	9.11	41.3	7.36	33.0	5.83	24.8	4.41	
5.0	4.1	79.7	79.7	20.7	71.7	16.9	63.8	13.7	55.8	11.1	47.8	9.05	39.9	7.31	31.9	5.79	23.9	4.38	
3.0	2.2	76.9	76.9	20.6	69.2	16.7	61.5	13.6	53.8	11.1	46.2	8.99	38.5	7.26	30.8	5.75	23.1	4.35	
0.0	-0.7	72.7	72.7	20.4	65.4	16.6	58.1	13.5	50.9	11.0	43.6	8.90	36.3	7.18	29.1	5.69	21.8	4.31	
-3.0	-3.7	68.3	68.3	20.1	61.4	16.4	54.6	13.3	47.8	10.8	41.0	8.80	34.1	7.11	27.3	5.63	20.5	4.26	
-5.0	-5.6	65.5	65.5	20.0	58.9	16.3	52.4	13.2	45.8	10.8	39.3	8.74	32.7	7.06	26.2	5.59	19.6	4.23	
-7.0	-7.6	62.5	62.5	19.9	56.3	16.2	50.0	13.1	43.8	10.7	37.5	8.68	31.3	7.01	25.0	5.55	18.8	4.20	
-10	-10.5	58.3	58.3	19.7	52.4	16.0	46.6	13.0	40.8	10.6	35.0	8.59	29.1	6.93	23.3	5.49	17.5	4.16	
-14.5	-15.0	51.7	51.7	19.3	46.5	15.7	41.3	12.8	36.2	10.4	31.0	8.45	25.8	6.82	20.7	5.40	15.5	4.09	

TC : Total Capacity PI : Power Input
 Indoor air temperature conditions : 20.0°C dry-bulb



MMY-AP2816HT8P-E (28HP, 78.5kW system)

Cooling		Compressor + Outdoor Fan Power consumption (kW)																	
		Outdoor Unit		100%		90%		80%		70%		60%		50%		40%		30%	
		(°C)	Capacity (kW)	TC (kW)	PI (kW)	TC (kW)	PI (kW)	TC (kW)	PI (kW)	TC (kW)	PI (kW)	TC (kW)	PI (kW)	TC (kW)	PI (kW)	TC (kW)	PI (kW)	TC (kW)	PI (kW)
40 °C	73.1	73.1	26.3	65.7	21.0	58.4	16.5	51.1	12.9	43.8	9.87	36.5	7.40	29.2	5.35	21.9	3.61		
39 °C	74.2	74.2	25.9	66.8	20.7	59.4	16.3	52.0	12.7	44.5	9.73	37.1	7.29	29.7	5.27	22.3	3.56		
37 °C	76.4	76.4	25.1	68.8	20.0	61.2	15.8	53.5	12.3	45.9	9.43	38.2	7.07	30.6	5.11	22.9	3.45		
35 °C	78.5	78.5	24.3	70.6	19.4	62.8	15.3	54.9	11.9	47.1	9.14	39.2	6.84	31.4	4.95	23.5	3.34		
33 °C	78.5	78.5	22.3	70.7	17.9	62.8	14.1	55.0	11.1	47.1	8.50	39.3	6.39	31.4	4.63	23.6	3.13		
31 °C	78.5	78.5	20.6	70.7	16.5	62.8	13.1	55.0	10.3	47.1	7.92	39.3	5.97	31.4	4.34	23.6	2.94		
30 °C	78.5	78.5	19.8	70.7	15.9	62.8	12.6	55.0	9.9	47.1	7.66	39.3	5.78	31.4	4.20	23.6	2.85		
29 °C	78.5	78.5	19.0	70.7	15.3	62.8	12.2	55.0	9.58	47.1	7.41	39.3	5.60	31.4	4.07	23.6	2.76		
27 °C	78.5	78.5	17.7	70.7	14.2	62.8	11.4	55.0	8.95	47.1	6.93	39.3	5.25	31.4	3.83	23.6	2.60		
25 °C	78.5	78.5	16.4	70.7	13.3	62.8	10.6	55.0	8.37	47.1	6.50	39.3	4.93	31.4	3.60	23.6	2.44		
23 °C	78.5	78.5	15.6	70.7	12.7	62.8	10.1	55.0	8.01	47.1	6.23	39.3	4.73	31.4	3.46	23.6	2.35		
21 °C	78.5	78.5	15.3	70.7	12.4	62.8	9.9	55.0	7.85	47.1	6.11	39.3	4.65	31.4	3.40	23.6	2.31		
20 °C	78.5	78.5	15.1	70.7	12.2	62.8	9.8	55.0	7.78	47.1	6.06	39.3	4.62	31.4	3.38	23.6	2.30		
19 °C	78.5	78.5	14.9	70.7	12.1	62.8	9.7	55.0	7.71	47.1	6.02	39.3	4.58	31.4	3.36	23.6	2.28		
17 °C	78.5	78.5	14.7	70.7	11.9	62.8	9.57	55.0	7.60	47.1	5.93	39.3	4.52	31.4	3.31	23.6	2.25		
15 °C	78.5	78.5	14.4	70.7	11.7	62.8	9.44	55.0	7.50	47.1	5.86	39.3	4.47	31.4	3.28	23.6	2.23		

TC : Total Capacity PI : Power Input
Indoor air temperature conditions : 27.0°C dry-bulb / 19.0°C wet bulb

Heating			Compressor + Outdoor Fan Power consumption (kW)																	
			Outdoor Unit		100%		90%		80%		70%		60%		50%		40%		30%	
			Dry-Bulb (°C)	Wet-Bulb (°C)	Capacity		Capacity		Capacity		Capacity		Capacity		Capacity		Capacity		Capacity	
15.0	13.7	87.5	87.5	18.5	78.8	15.5	70.0	12.9	61.3	10.6	52.5	8.75	43.8	7.11	35.0	5.66	26.3	4.32		
13.0	11.8	87.5	87.5	19.4	78.8	16.1	70.0	13.3	61.3	11.0	52.5	9.01	43.8	7.30	35.0	5.79	26.3	4.41		
11.0	9.8	87.5	87.5	20.4	78.8	16.8	70.0	13.9	61.3	11.4	52.5	9.31	43.8	7.51	35.0	5.94	26.3	4.51		
9.0	7.9	87.5	87.5	21.4	78.8	17.6	70.0	14.5	61.3	11.8	52.5	9.61	43.8	7.73	35.0	6.09	26.3	4.62		
7.0	6.0	87.5	87.5	22.5	78.8	18.5	70.0	15.1	61.3	12.3	52.5	9.94	43.8	7.96	35.0	6.25	26.3	4.73		
5.0	4.1	84.4	84.4	22.4	75.9	18.4	67.5	15.0	59.1	12.2	50.6	9.87	42.2	7.90	33.7	6.20	25.3	4.69		
3.0	2.2	81.2	81.2	22.2	73.1	18.2	65.0	14.9	56.9	12.1	48.7	9.79	40.6	7.84	32.5	6.16	24.4	4.65		
0.0	-0.7	76.4	76.4	21.9	68.8	18.0	61.2	14.7	53.5	12.0	45.9	9.68	38.2	7.75	30.6	6.08	22.9	4.60		
-3.0	-3.7	71.5	71.5	21.7	64.4	17.8	57.2	14.5	50.1	11.8	42.9	9.56	35.8	7.65	28.6	6.01	21.5	4.54		
-5.0	-5.6	68.4	68.4	21.5	61.5	17.6	54.7	14.4	47.9	11.7	41.0	9.48	34.2	7.59	27.3	5.96	20.5	4.51		
-7.0	-7.6	65.1	65.1	21.3	58.6	17.5	52.1	14.3	45.5	11.6	39.0	9.40	32.5	7.53	26.0	5.91	19.5	4.47		
-10	-10.5	60.3	60.3	21.1	54.3	17.3	48.2	14.1	42.2	11.5	36.2	9.29	30.1	7.43	24.1	5.84	18.1	4.41		
-14.5	-15.0	52.9	52.9	20.7	47.6	17.0	42.3	13.9	37.0	11.3	31.7	9.11	26.4	7.29	21.1	5.73	15.9	4.33		

TC : Total Capacity PI : Power Input
Indoor air temperature conditions : 20.0°C dry-bulb



MMY-AP3016HT8P-E (30HP, 85kW system)

Cooling		Compressor + Outdoor Fan Power consumption (kW)																	
		Outdoor Unit		100%		90%		80%		70%		60%		50%		40%		30%	
		(°C)	Capacity (kW)	TC (kW)	PI (kW)	TC (kW)	PI (kW)	TC (kW)	PI (kW)	TC (kW)	PI (kW)	TC (kW)	PI (kW)	TC (kW)	PI (kW)	TC (kW)	PI (kW)	TC (kW)	PI (kW)
40 °C	79.1	79.1	28.7	71.2	22.8	63.3	17.9	55.4	13.9	47.5	10.7	39.6	8.10	31.6	5.92	23.7	4.03		
39 °C	80.4	80.4	28.3	72.3	22.5	64.3	17.6	56.3	13.7	48.2	10.6	40.2	7.98	32.2	5.84	24.1	3.97		
37 °C	82.8	82.8	27.5	74.5	21.8	66.2	17.1	57.9	13.3	49.7	10.2	41.4	7.74	33.1	5.66	24.8	3.85		
35 °C	85.0	85.0	26.6	76.5	21.1	68.0	16.6	59.5	12.9	51.0	9.9	42.5	7.50	34.0	5.48	25.5	3.73		
33 °C	85.0	85.0	24.4	76.5	19.4	68.0	15.3	59.5	12.0	51.0	9.23	42.5	7.00	34.0	5.13	25.5	3.49		
31 °C	85.0	85.0	22.4	76.5	17.9	68.0	14.2	59.5	11.1	51.0	8.62	42.5	6.56	34.0	4.82	25.5	3.27		
30 °C	85.0	85.0	21.6	76.5	17.2	68.0	13.7	59.5	10.7	51.0	8.34	42.5	6.35	34.0	4.67	25.5	3.17		
29 °C	85.0	85.0	20.7	76.5	16.6	68.0	13.2	59.5	10.4	51.0	8.06	42.5	6.15	34.0	4.52	25.5	3.07		
27 °C	85.0	85.0	19.2	76.5	15.4	68.0	12.3	59.5	9.69	51.0	7.56	42.5	5.78	34.0	4.25	25.5	2.89		
25 °C	85.0	85.0	17.9	76.5	14.4	68.0	11.5	59.5	9.07	51.0	7.09	42.5	5.43	34.0	4.00	25.5	2.72		
23 °C	85.0	85.0	17.0	76.5	13.7	68.0	11.0	59.5	8.68	51.0	6.80	42.5	5.21	34.0	3.85	25.5	2.61		
21 °C	85.0	85.0	16.6	76.5	13.4	68.0	10.7	59.5	8.51	51.0	6.68	42.5	5.13	34.0	3.79	25.5	2.57		
20 °C	85.0	85.0	16.4	76.5	13.2	68.0	10.6	59.5	8.44	51.0	6.62	42.5	5.09	34.0	3.76	25.5	2.55		
19 °C	85.0	85.0	16.2	76.5	13.1	68.0	10.5	59.5	8.37	51.0	6.57	42.5	5.05	34.0	3.73	25.5	2.53		
17 °C	85.0	85.0	15.9	76.5	12.9	68.0	10.4	59.5	8.24	51.0	6.48	42.5	4.99	34.0	3.69	25.5	2.50		
15 °C	85.0	85.0	15.7	76.5	12.7	68.0	10.2	59.5	8.14	51.0	6.41	42.5	4.94	34.0	3.65	25.5	2.47		

TC : Total Capacity PI : Power Input
 Indoor air temperature conditions : 27.0°C dry-bulb / 19.0°C wet bulb

Heating			Compressor + Outdoor Fan Power consumption (kW)																	
			Outdoor Unit		100%		90%		80%		70%		60%		50%		40%		30%	
			Dry-Bulb (°C)	Wet-Bulb (°C)	Capacity (kW)	TC (kW)	PI (kW)	TC (kW)	PI (kW)	TC (kW)	PI (kW)	TC (kW)	PI (kW)	TC (kW)	PI (kW)	TC (kW)	PI (kW)	TC (kW)	PI (kW)	TC (kW)
15.0	13.7	95.0	95.0	19.7	85.5	16.3	76.0	13.5	66.5	11.2	57.0	9.20	47.5	7.56	38.0	6.15	28.5	4.92		
13.0	11.8	95.0	95.0	20.6	85.5	17.0	76.0	14.0	66.5	11.5	57.0	9.47	47.5	7.74	38.0	6.28	28.5	5.00		
11.0	9.8	95.0	95.0	21.7	85.5	17.8	76.0	14.6	66.5	12.0	57.0	9.77	47.5	7.95	38.0	6.42	28.5	5.09		
9.0	7.9	95.0	95.0	22.8	85.5	18.7	76.0	15.3	66.5	12.4	57.0	10.1	47.5	8.16	38.0	6.56	28.5	5.18		
7.0	6.0	95.0	95.0	24.1	85.5	19.7	76.0	16.0	66.5	12.9	57.0	10.4	47.5	8.40	38.0	6.71	28.5	5.28		
5.0	4.1	91.8	91.8	23.9	82.6	19.5	73.4	15.9	64.2	12.8	55.1	10.4	45.9	8.34	36.7	6.67	27.5	5.24		
3.0	2.2	88.5	88.5	23.8	79.7	19.4	70.8	15.7	62.0	12.7	53.1	10.3	44.3	8.28	35.4	6.62	26.6	5.21		
0.0	-0.7	83.6	83.6	23.5	75.2	19.2	66.9	15.6	58.5	12.6	50.1	10.2	41.8	8.20	33.4	6.55	25.1	5.15		
-3.0	-3.7	78.5	78.5	23.3	70.6	19.0	62.8	15.4	54.9	12.5	47.1	10.1	39.2	8.11	31.4	6.48	23.5	5.10		
-5.0	-5.6	75.2	75.2	23.1	67.7	18.8	60.2	15.3	52.7	12.4	45.1	10.0	37.6	8.05	30.1	6.44	22.6	5.06		
-7.0	-7.6	71.8	71.8	22.9	64.6	18.7	57.5	15.2	50.3	12.3	43.1	9.93	35.9	7.99	28.7	6.39	21.5	5.03		
-10	-10.5	66.9	66.9	22.7	60.2	18.5	53.5	15.0	46.8	12.2	40.1	9.82	33.4	7.91	26.8	6.32	20.1	4.97		
-14.5	-15.0	59.2	59.2	22.3	53.3	18.2	47.4	14.8	41.5	12.0	35.5	9.65	29.6	7.77	23.7	6.21	17.8	4.89		

TC : Total Capacity PI : Power Input
 Indoor air temperature conditions : 20.0°C dry-bulb



MMY-AP3216HT8P-E (32HP, 90kW system)

Cooling		Compressor + Outdoor Fan Power consumption (kW)																	
		Outdoor Unit		100%		90%		80%		70%		60%		50%		40%		30%	
		(°C)	Capacity (kW)	TC (kW)	PI (kW)	TC (kW)	PI (kW)	TC (kW)	PI (kW)	TC (kW)	PI (kW)	TC (kW)	PI (kW)	TC (kW)	PI (kW)	TC (kW)	PI (kW)	TC (kW)	PI (kW)
40 °C	83.8	83.8	30.9	75.4	24.6	67.0	19.4	58.6	15.1	50.3	11.5	41.9	8.62	33.5	6.21	25.1	4.15		
39 °C	85.1	85.1	30.4	76.6	24.3	68.1	19.1	59.6	14.9	51.1	11.4	42.6	8.49	34.0	6.11	25.5	4.09		
37 °C	87.6	87.6	29.5	78.9	23.5	70.1	18.5	61.4	14.4	52.6	11.0	43.8	8.24	35.1	5.93	26.3	3.97		
35 °C	90.0	90.0	28.6	81.0	22.8	72.0	17.9	63.0	14.0	54.0	10.7	45.0	7.98	36.0	5.74	27.0	3.84		
33 °C	90.0	90.0	26.2	81.0	21.0	72.0	16.6	63.0	12.9	54.0	9.92	45.0	7.44	36.0	5.37	27.0	3.60		
31 °C	90.0	90.0	24.2	81.0	19.4	72.0	15.4	63.0	12.0	54.0	9.25	45.0	6.96	36.0	5.03	27.0	3.37		
30 °C	90.0	90.0	23.3	81.0	18.7	72.0	14.8	63.0	11.6	54.0	8.94	45.0	6.73	36.0	4.87	27.0	3.26		
29 °C	90.0	90.0	22.4	81.0	18.0	72.0	14.3	63.0	11.2	54.0	8.64	45.0	6.52	36.0	4.72	27.0	3.16		
27 °C	90.0	90.0	20.8	81.0	16.7	72.0	13.3	63.0	10.5	54.0	8.09	45.0	6.11	36.0	4.43	27.0	2.97		
25 °C	90.0	90.0	19.3	81.0	15.6	72.0	12.4	63.0	9.78	54.0	7.58	45.0	5.74	36.0	4.17	27.0	2.79		
23 °C	90.0	90.0	18.4	81.0	14.8	72.0	11.9	63.0	9.36	54.0	7.27	45.0	5.51	36.0	4.00	27.0	2.68		
21 °C	90.0	90.0	17.9	81.0	14.5	72.0	11.6	63.0	9.17	54.0	7.13	45.0	5.41	36.0	3.94	27.0	2.64		
20 °C	90.0	90.0	17.7	81.0	14.3	72.0	11.5	63.0	9.09	54.0	7.07	45.0	5.37	36.0	3.91	27.0	2.62		
19 °C	90.0	90.0	17.5	81.0	14.2	72.0	11.4	63.0	9.01	54.0	7.02	45.0	5.33	36.0	3.88	27.0	2.60		
17 °C	90.0	90.0	17.2	81.0	14.0	72.0	11.2	63.0	8.87	54.0	6.92	45.0	5.26	36.0	3.83	27.0	2.57		
15 °C	90.0	90.0	16.9	81.0	13.7	72.0	11.0	63.0	8.76	54.0	6.83	45.0	5.20	36.0	3.79	27.0	2.54		

TC : Total Capacity PI : Power Input
 Indoor air temperature conditions : 27.0°C dry-bulb / 19.0°C wet bulb

Heating			Compressor + Outdoor Fan Power consumption (kW)																	
			Outdoor Unit		100%		90%		80%		70%		60%		50%		40%		30%	
			Dry-Bulb (°C)	Wet-Bulb (°C)	Capacity (kW)	TC (kW)	PI (kW)	TC (kW)	PI (kW)	TC (kW)	PI (kW)	TC (kW)	PI (kW)	TC (kW)	PI (kW)	TC (kW)	PI (kW)	TC (kW)	PI (kW)	TC (kW)
15.0	13.7	100.0	100.0	21.2	90.0	17.7	80.0	14.6	70.0	12.1	60.0	9.89	50.0	8.07	40.0	6.53	30.0	5.23		
13.0	11.8	100.0	100.0	22.2	90.0	18.4	80.0	15.2	70.0	12.5	60.0	10.2	50.0	8.27	40.0	6.66	30.0	5.31		
11.0	9.8	100.0	100.0	23.3	90.0	19.3	80.0	15.9	70.0	13.0	60.0	10.5	50.0	8.50	40.0	6.81	30.0	5.40		
9.0	7.9	100.0	100.0	24.5	90.0	20.2	80.0	16.5	70.0	13.5	60.0	10.9	50.0	8.74	40.0	6.97	30.0	5.50		
7.0	6.0	100.0	100.0	25.8	90.0	21.2	80.0	17.3	70.0	14.0	60.0	11.3	50.0	9.00	40.0	7.14	30.0	5.60		
5.0	4.1	96.4	96.4	25.6	86.8	21.0	77.1	17.2	67.5	13.9	57.9	11.2	48.2	8.93	38.6	7.08	28.9	5.56		
3.0	2.2	92.8	92.8	25.4	83.6	20.9	74.3	17.0	65.0	13.8	55.7	11.1	46.4	8.86	37.1	7.03	27.9	5.51		
0.0	-0.7	87.4	87.4	25.1	78.6	20.6	69.9	16.8	61.2	13.6	52.4	11.0	43.7	8.76	34.9	6.94	26.2	5.45		
-3.0	-3.7	81.7	81.7	24.8	73.5	20.4	65.4	16.6	57.2	13.5	49.0	10.8	40.9	8.65	32.7	6.86	24.5	5.38		
-5.0	-5.6	78.1	78.1	24.6	70.3	20.2	62.5	16.5	54.7	13.3	46.9	10.7	39.1	8.58	31.3	6.80	23.4	5.34		
-7.0	-7.6	74.4	74.4	24.4	66.9	20.0	59.5	16.3	52.1	13.2	44.6	10.6	37.2	8.51	29.7	6.75	22.3	5.29		
-10	-10.5	68.9	68.9	24.1	62.0	19.8	55.1	16.1	48.2	13.1	41.3	10.5	34.5	8.41	27.6	6.67	20.7	5.23		
-14.5	-15.0	60.4	60.4	23.6	54.4	19.4	48.3	15.8	42.3	12.8	36.3	10.3	30.2	8.24	24.2	6.54	18.1	5.13		

TC : Total Capacity PI : Power Input
 Indoor air temperature conditions : 20.0°C dry-bulb



MMY-AP3416HT8P-E (34HP, 95.4kW system)

Cooling		Compressor + Outdoor Fan Power consumption (kW)																	
		Outdoor Unit (°C)	Outdoor Unit 100% Capacity (kW)	100%		90%		80%		70%		60%		50%		40%		30%	
				TC (kW)	PI (kW)	TC (kW)	PI (kW)	TC (kW)	PI (kW)	TC (kW)	PI (kW)	TC (kW)	PI (kW)	TC (kW)	PI (kW)	TC (kW)	PI (kW)	TC (kW)	PI (kW)
40 °C	88.8	88.8	31.2	79.9	25.1	71.0	20.0	62.1	15.7	53.3	12.2	44.4	9.27	35.5	6.79	26.6	4.62		
39 °C	90.2	90.2	30.8	81.2	24.7	72.2	19.7	63.1	15.5	54.1	12.0	45.1	9.13	36.1	6.69	27.1	4.55		
37 °C	92.9	92.9	29.8	83.6	24.0	74.3	19.1	65.0	15.0	55.7	11.6	46.5	8.85	37.2	6.49	27.9	4.41		
35 °C	95.4	95.4	28.9	85.8	23.2	76.3	18.5	66.8	14.5	57.2	11.3	47.7	8.57	38.2	6.28	28.6	4.27		
33 °C	95.4	95.4	26.6	85.9	21.4	76.3	17.1	66.8	13.5	57.2	10.5	47.7	8.01	38.2	5.88	28.6	4.00		
31 °C	95.4	95.4	24.5	85.9	19.8	76.3	15.9	66.8	12.6	57.2	9.82	47.7	7.50	38.2	5.52	28.6	3.76		
30 °C	95.4	95.4	23.6	85.9	19.1	76.3	15.3	66.8	12.1	57.2	9.50	47.7	7.27	38.2	5.35	28.6	3.64		
29 °C	95.4	95.4	22.7	85.9	18.4	76.3	14.8	66.8	11.7	57.2	9.19	47.7	7.04	38.2	5.18	28.6	3.53		
27 °C	95.4	95.4	21.1	85.9	17.1	76.3	13.8	66.8	11.0	57.2	8.62	47.7	6.61	38.2	4.88	28.6	3.32		
25 °C	95.4	95.4	19.6	85.9	16.0	76.3	12.9	66.8	10.3	57.2	8.09	47.7	6.21	38.2	4.59	28.6	3.12		
23 °C	95.4	95.4	18.7	85.9	15.3	76.3	12.3	66.8	9.85	57.2	7.76	47.7	5.97	38.2	4.41	28.6	3.00		
21 °C	95.4	95.4	18.3	85.9	14.9	76.3	12.1	66.8	9.67	57.2	7.62	47.7	5.87	38.2	4.34	28.6	2.95		
20 °C	95.4	95.4	18.1	85.9	14.8	76.3	12.0	66.8	9.58	57.2	7.56	47.7	5.83	38.2	4.31	28.6	2.93		
19 °C	95.4	95.4	17.9	85.9	14.6	76.3	11.9	66.8	9.51	57.2	7.51	47.7	5.79	38.2	4.28	28.6	2.91		
17 °C	95.4	95.4	17.6	85.9	14.4	76.3	11.7	66.8	9.37	57.2	7.41	47.7	5.72	38.2	4.23	28.6	2.87		
15 °C	95.4	95.4	17.3	85.9	14.2	76.3	11.5	66.8	9.25	57.2	7.32	47.7	5.65	38.2	4.18	28.6	2.84		

TC : Total Capacity PI : Power Input
 Indoor air temperature conditions : 27.0°C dry-bulb / 19.0°C wet bulb

Heating			Compressor + Outdoor Fan Power consumption (kW)																		
			Outdoor Unit Dry-Bulb (°C)	Outdoor Unit Wet-Bulb (°C)	Outdoor Unit Heating Capacity (kW)	100%		90%		80%		70%		60%		50%		40%		30%	
						TC (kW)	PI (kW)	TC (kW)	PI (kW)	TC (kW)	PI (kW)	TC (kW)	PI (kW)	TC (kW)	PI (kW)	TC (kW)	PI (kW)	TC (kW)	PI (kW)	TC (kW)	PI (kW)
15.0	13.7	106.0	106.0	22.3	95.4	18.7	84.8	15.6	74.2	13.0	63.6	10.6	53.0	8.63	42.4	6.86	31.8	5.27			
13.0	11.8	106.0	106.0	23.3	95.4	19.5	84.8	16.2	74.2	13.4	63.6	11.0	53.0	8.86	42.4	7.02	31.8	5.38			
11.0	9.8	106.0	106.0	24.5	95.4	20.4	84.8	16.9	74.2	13.9	63.6	11.3	53.0	9.12	42.4	7.20	31.8	5.50			
9.0	7.9	106.0	106.0	25.7	95.4	21.3	84.8	17.6	74.2	14.4	63.6	11.7	53.0	9.38	42.4	7.39	31.8	5.62			
7.0	6.0	106.0	106.0	27.0	95.4	22.3	84.8	18.3	74.2	15.0	63.6	12.1	53.0	9.67	42.4	7.58	31.8	5.75			
5.0	4.1	102.4	102.4	26.8	92.2	22.2	81.9	18.2	71.7	14.9	61.4	12.0	51.2	9.61	41.0	7.53	30.7	5.71			
3.0	2.2	98.8	98.8	26.6	88.9	22.0	79.1	18.1	69.2	14.8	59.3	11.9	49.4	9.54	39.5	7.48	29.6	5.67			
0.0	-0.7	93.3	93.3	26.4	84.0	21.8	74.7	17.9	65.3	14.6	56.0	11.8	46.7	9.45	37.3	7.41	28.0	5.61			
-3.0	-3.7	87.7	87.7	26.1	78.9	21.6	70.1	17.7	61.4	14.5	52.6	11.7	43.8	9.35	35.1	7.33	26.3	5.55			
-5.0	-5.6	84.1	84.1	25.9	75.7	21.4	67.3	17.6	58.9	14.4	50.4	11.6	42.0	9.28	33.6	7.28	25.2	5.52			
-7.0	-7.6	80.3	80.3	25.7	72.3	21.3	64.2	17.5	56.2	14.3	48.2	11.5	40.1	9.22	32.1	7.23	24.1	5.48			
-10	-10.5	74.8	74.8	25.4	67.3	21.0	59.8	17.3	52.4	14.1	44.9	11.4	37.4	9.12	29.9	7.15	22.4	5.42			
-14.5	-15.0	66.3	66.3	25.0	59.7	20.7	53.0	17.0	46.4	13.9	39.8	11.2	33.2	8.97	26.5	7.03	19.9	5.33			

TC : Total Capacity PI : Power Input
 Indoor air temperature conditions : 20.0°C dry-bulb



MMY-AP3616HT8P-E (36HP, 101kW system)

Cooling		Compressor + Outdoor Fan Power consumption (kW)																	
		Outdoor Unit		100%		90%		80%		70%		60%		50%		40%		30%	
		(°C)	Capacity (kW)	TC (kW)	PI (kW)	TC (kW)	PI (kW)	TC (kW)	PI (kW)	TC (kW)	PI (kW)	TC (kW)	PI (kW)	TC (kW)	PI (kW)	TC (kW)	PI (kW)	TC (kW)	PI (kW)
40 °C	94.0	94.0	34.1	84.6	27.4	75.2	21.7	65.8	17.0	56.4	13.2	47.0	9.94	37.6	7.23	28.2	4.88		
39 °C	95.5	95.5	33.6	86.0	27.0	76.4	21.4	66.9	16.8	57.3	13.0	47.8	9.79	38.2	7.12	28.7	4.81		
37 °C	98.4	98.4	32.6	88.5	26.1	78.7	20.7	68.8	16.3	59.0	12.6	49.2	9.49	39.3	6.91	29.5	4.66		
35 °C	101.0	101.0	31.6	90.9	25.3	80.8	20.1	70.7	15.8	60.6	12.2	50.5	9.19	40.4	6.69	30.3	4.51		
33 °C	101.0	101.0	29.0	90.9	23.3	80.8	18.6	70.7	14.6	60.6	11.3	50.5	8.59	40.4	6.26	30.3	4.22		
31 °C	101.0	101.0	26.8	90.9	21.6	80.8	17.2	70.7	13.6	60.6	10.58	50.5	8.04	40.4	5.87	30.3	3.96		
30 °C	101.0	101.0	25.8	90.9	20.8	80.8	16.6	70.7	13.1	60.6	10.23	50.5	7.78	40.4	5.69	30.3	3.84		
29 °C	101.0	101.0	24.8	90.9	20.1	80.8	16.1	70.7	12.7	60.6	9.90	50.5	7.54	40.4	5.51	30.3	3.72		
27 °C	101.0	101.0	23.0	90.9	18.7	80.8	15.0	70.7	11.9	60.6	9.27	50.5	7.07	40.4	5.18	30.3	3.49		
25 °C	101.0	101.0	21.4	90.9	17.4	80.8	14.0	70.7	11.1	60.6	8.70	50.5	6.65	40.4	4.87	30.3	3.28		
23 °C	101.0	101.0	20.4	90.9	16.6	80.8	13.4	70.7	10.6	60.6	8.34	50.5	6.38	40.4	4.68	30.3	3.16		
21 °C	101.0	101.0	19.9	90.9	16.2	80.8	13.1	70.7	10.4	60.6	8.19	50.5	6.28	40.4	4.61	30.3	3.10		
20 °C	101.0	101.0	19.7	90.9	16.1	80.8	13.0	70.7	10.3	60.6	8.13	50.5	6.23	40.4	4.57	30.3	3.08		
19 °C	101.0	101.0	19.5	90.9	15.9	80.8	12.9	70.7	10.3	60.6	8.06	50.5	6.18	40.4	4.54	30.3	3.06		
17 °C	101.0	101.0	19.2	90.9	15.6	80.8	12.6	70.7	10.1	60.6	7.95	50.5	6.10	40.4	4.48	30.3	3.02		
15 °C	101.0	101.0	18.9	90.9	15.4	80.8	12.5	70.7	9.98	60.6	7.86	50.5	6.04	40.4	4.44	30.3	2.99		

TC : Total Capacity PI : Power Input
 Indoor air temperature conditions : 27.0°C dry-bulb / 19.0°C wet bulb

Heating			Compressor + Outdoor Fan Power consumption (kW)																	
			Outdoor Unit		100%		90%		80%		70%		60%		50%		40%		30%	
			Dry-Bulb (°C)	Wet-Bulb (°C)	Capacity (kW)	TC (kW)	PI (kW)	TC (kW)	PI (kW)	TC (kW)	PI (kW)	TC (kW)	PI (kW)	TC (kW)	PI (kW)	TC (kW)	PI (kW)	TC (kW)	PI (kW)	TC (kW)
15.0	13.7	113.0	113.0	24.8	101.7	20.8	90.4	17.4	79.1	14.4	67.8	11.8	56.5	9.56	45.2	7.51	33.9	5.63		
13.0	11.8	113.0	113.0	25.9	101.7	21.7	90.4	18.0	79.1	14.9	67.8	12.2	56.5	9.82	45.2	7.70	33.9	5.76		
11.0	9.8	113.0	113.0	27.1	101.7	22.6	90.4	18.8	79.1	15.5	67.8	12.6	56.5	10.1	45.2	7.91	33.9	5.91		
9.0	7.9	113.0	113.0	28.4	101.7	23.6	90.4	19.5	79.1	16.0	67.8	13.0	56.5	10.4	45.2	8.13	33.9	6.05		
7.0	6.0	113.0	113.0	29.9	101.7	24.8	90.4	20.4	79.1	16.6	67.8	13.5	56.5	10.7	45.2	8.35	33.9	6.21		
5.0	4.1	109.0	109.0	29.7	98.1	24.6	87.2	20.2	76.3	16.5	65.4	13.4	54.5	10.7	43.6	8.29	32.7	6.16		
3.0	2.2	104.9	104.9	29.4	94.4	24.4	83.9	20.1	73.4	16.4	62.9	13.3	52.5	10.6	42.0	8.23	31.5	6.12		
0.0	-0.7	98.7	98.7	29.1	88.9	24.1	79.0	19.8	69.1	16.2	59.2	13.1	49.4	10.5	39.5	8.13	29.6	6.04		
-3.0	-3.7	92.3	92.3	28.7	83.1	23.8	73.9	19.6	64.6	16.0	55.4	12.9	46.2	10.3	36.9	8.03	27.7	5.97		
-5.0	-5.6	88.3	88.3	28.5	79.5	23.6	70.6	19.4	61.8	15.9	53.0	12.8	44.1	10.2	35.3	7.97	26.5	5.92		
-7.0	-7.6	84.0	84.0	28.3	75.6	23.4	67.2	19.3	58.8	15.7	50.4	12.7	42.0	10.2	33.6	7.90	25.2	5.87		
-10	-10.5	77.9	77.9	27.9	70.1	23.1	62.3	19.0	54.5	15.5	46.7	12.6	38.9	10.0	31.1	7.80	23.4	5.80		
-14.5	-15.0	68.3	68.3	27.4	61.4	22.7	54.6	18.7	47.8	15.3	41.0	12.3	34.1	9.84	27.3	7.65	20.5	5.69		

TC : Total Capacity PI : Power Input
 Indoor air temperature conditions : 20.0°C dry-bulb



MMY-AP3816HT8P-E (38HP, 106.5kW system)

Cooling		Compressor + Outdoor Fan Power consumption (kW)																	
		Outdoor Unit 100% Capacity (kW)		100%		90%		80%		70%		60%		50%		40%		30%	
		TC	PI	TC	PI	TC	PI	TC	PI	TC	PI	TC	PI	TC	PI	TC	PI	TC	PI
40 °C	99.1	99.1	40.5	89.2	32.0	79.3	24.9	69.4	19.1	59.5	14.4	49.6	10.53	39.6	7.46	29.7	4.98		
39 °C	100.7	100.7	39.9	90.6	31.5	80.6	24.6	70.5	18.8	60.4	14.1	50.4	10.38	40.3	7.35	30.2	4.91		
37 °C	103.7	103.7	38.7	93.3	30.6	83.0	23.8	72.6	18.2	62.2	13.7	51.9	10.06	41.5	7.13	31.1	4.76		
35 °C	106.5	106.5	37.5	95.8	29.6	85.2	23.1	74.5	17.7	63.9	13.3	53.2	9.74	42.6	6.90	31.9	4.61		
33 °C	106.5	106.5	34.3	95.9	27.2	85.2	21.2	74.6	16.3	63.9	12.3	53.3	9.07	42.6	6.45	32.0	4.32		
31 °C	106.5	106.5	31.6	95.9	25.1	85.2	19.6	74.6	15.1	63.9	11.5	53.3	8.46	42.6	6.04	32.0	4.05		
30 °C	106.5	106.5	30.4	95.9	24.1	85.2	18.9	74.6	14.6	63.9	11.1	53.3	8.18	42.6	5.84	32.0	3.93		
29 °C	106.5	106.5	29.2	95.9	23.2	85.2	18.2	74.6	14.1	63.9	10.7	53.3	7.91	42.6	5.66	32.0	3.81		
27 °C	106.5	106.5	27.1	95.9	21.6	85.2	17.0	74.6	13.1	63.9	9.98	53.3	7.41	42.6	5.31	32.0	3.58		
25 °C	106.5	106.5	25.1	95.9	20.1	85.2	15.8	74.6	12.3	63.9	9.34	53.3	6.95	42.6	4.99	32.0	3.37		
23 °C	106.5	106.5	23.9	95.9	19.1	85.2	15.1	74.6	11.7	63.9	8.94	53.3	6.67	42.6	4.80	32.0	3.24		
21 °C	106.5	106.5	23.3	95.9	18.6	85.2	14.7	74.6	11.5	63.9	8.76	53.3	6.54	42.6	4.72	32.0	3.19		
20 °C	106.5	106.5	23.0	95.9	18.4	85.2	14.6	74.6	11.3	63.9	8.68	53.3	6.49	42.6	4.68	32.0	3.17		
19 °C	106.5	106.5	22.8	95.9	18.2	85.2	14.4	74.6	11.2	63.9	8.61	53.3	6.44	42.6	4.65	32.0	3.15		
17 °C	106.5	106.5	22.3	95.9	17.9	85.2	14.2	74.6	11.1	63.9	8.48	53.3	6.35	42.6	4.59	32.0	3.11		
15 °C	106.5	106.5	21.9	95.9	17.6	85.2	14.0	74.6	10.9	63.9	8.37	53.3	6.28	42.6	4.54	32.0	3.08		

TC : Total Capacity PI : Power Input
Indoor air temperature conditions : 27.0°C dry-bulb / 19.0°C wet bulb

Heating			Compressor + Outdoor Fan Power consumption (kW)																	
			Outdoor Unit 100% Heating Capacity (kW)		100%		90%		80%		70%		60%		50%		40%		30%	
			TC	PI	TC	PI	TC	PI	TC	PI	TC	PI	TC	PI	TC	PI	TC	PI	TC	PI
15.0	13.7	114.0	114.0	26.2	102.6	22.0	91.2	18.4	79.8	15.3	68.4	12.6	57.0	10.2	45.6	8.03	34.2	5.99		
13.0	11.8	114.0	114.0	27.4	102.6	22.9	91.2	19.1	79.8	15.8	68.4	13.0	57.0	10.5	45.6	8.23	34.2	6.13		
11.0	9.8	114.0	114.0	28.7	102.6	23.9	91.2	19.8	79.8	16.4	68.4	13.4	57.0	10.8	45.6	8.45	34.2	6.29		
9.0	7.9	114.0	114.0	30.1	102.6	25.0	91.2	20.7	79.8	17.0	68.4	13.8	57.0	11.1	45.6	8.68	34.2	6.45		
7.0	6.0	114.0	114.0	31.7	102.6	26.2	91.2	21.5	79.8	17.6	68.4	14.3	57.0	11.4	45.6	8.93	34.2	6.62		
5.0	4.1	109.9	109.9	31.5	98.9	26.0	87.9	21.4	76.9	17.5	65.9	14.2	55.0	11.4	44.0	8.86	33.0	6.57		
3.0	2.2	105.8	105.8	31.2	95.2	25.8	84.7	21.2	74.1	17.4	63.5	14.1	52.9	11.3	42.3	8.79	31.7	6.52		
0.0	-0.7	99.6	99.6	30.8	89.6	25.5	79.7	21.0	69.7	17.1	59.8	13.9	49.8	11.1	39.8	8.69	29.9	6.45		
-3.0	-3.7	93.2	93.2	30.5	83.8	25.2	74.5	20.7	65.2	16.9	55.9	13.7	46.6	11.0	37.3	8.58	27.9	6.37		
-5.0	-5.6	89.1	89.1	30.2	80.2	25.0	71.3	20.5	62.4	16.8	53.4	13.6	44.5	10.9	35.6	8.51	26.7	6.32		
-7.0	-7.6	84.8	84.8	30.0	76.3	24.8	67.8	20.4	59.3	16.7	50.9	13.5	42.4	10.8	33.9	8.44	25.4	6.26		
-10	-10.5	78.5	78.5	29.6	70.7	24.5	62.8	20.1	55.0	16.5	47.1	13.4	39.3	10.7	31.4	8.34	23.6	6.19		
-14.5	-15.0	68.9	68.9	29.0	62.0	24.0	55.1	19.7	48.2	16.1	41.3	13.1	34.4	10.5	27.6	8.18	20.7	6.07		

TC : Total Capacity PI : Power Input
Indoor air temperature conditions : 20.0°C dry-bulb



MMY-AP4016HT8P-E (40HP, 112kW system)

Cooling		Compressor + Outdoor Fan Power consumption (kW)																	
		Outdoor Unit		100%		90%		80%		70%		60%		50%		40%		30%	
		(°C)	Capacity (kW)	TC (kW)	PI (kW)	TC (kW)	PI (kW)	TC (kW)	PI (kW)	TC (kW)	PI (kW)	TC (kW)	PI (kW)	TC (kW)	PI (kW)	TC (kW)	PI (kW)	TC (kW)	PI (kW)
40 °C	104.2	104.2	37.4	93.8	30.1	83.4	24.0	73.0	19.0	62.5	14.8	52.1	11.25	41.7	8.25	31.3	5.60		
39 °C	105.9	105.9	36.8	95.3	29.7	84.7	23.7	74.1	18.7	63.5	14.6	53.0	11.09	42.4	8.13	31.8	5.52		
37 °C	109.1	109.1	35.7	98.2	28.8	87.3	23.0	76.3	18.1	65.4	14.1	54.5	10.75	43.6	7.89	32.7	5.35		
35 °C	112.0	112.0	34.6	100.8	27.9	89.6	22.2	78.4	17.6	67.2	13.7	56.0	10.41	44.8	7.64	33.6	5.18		
33 °C	112.0	112.0	31.8	100.8	25.7	89.6	20.6	78.4	16.3	67.2	12.7	56.0	9.73	44.8	7.15	33.6	4.85		
31 °C	112.0	112.0	29.4	100.8	23.8	89.6	19.1	78.4	15.2	67.2	11.9	56.0	9.12	44.8	6.71	33.6	4.55		
30 °C	112.0	112.0	28.3	100.8	22.9	89.6	18.5	78.4	14.7	67.2	11.5	56.0	8.83	44.8	6.50	33.6	4.41		
29 °C	112.0	112.0	27.2	100.8	22.1	89.6	17.8	78.4	14.2	67.2	11.1	56.0	8.56	44.8	6.30	33.6	4.27		
27 °C	112.0	112.0	25.3	100.8	20.6	89.6	16.6	78.4	13.3	67.2	10.5	56.0	8.04	44.8	5.93	33.6	4.02		
25 °C	112.0	112.0	23.6	100.8	19.2	89.6	15.6	78.4	12.4	67.2	9.81	56.0	7.55	44.8	5.57	33.6	3.78		
23 °C	112.0	112.0	22.5	100.8	18.4	89.6	14.9	78.4	11.9	67.2	9.42	56.0	7.26	44.8	5.36	33.6	3.63		
21 °C	112.0	112.0	22.0	100.8	18.0	89.6	14.6	78.4	11.7	67.2	9.25	56.0	7.14	44.8	5.28	33.6	3.57		
20 °C	112.0	112.0	21.7	100.8	17.8	89.6	14.4	78.4	11.6	67.2	9.18	56.0	7.09	44.8	5.24	33.6	3.54		
19 °C	112.0	112.0	21.5	100.8	17.6	89.6	14.3	78.4	11.5	67.2	9.11	56.0	7.04	44.8	5.20	33.6	3.52		
17 °C	112.0	112.0	21.1	100.8	17.3	89.6	14.1	78.4	11.3	67.2	8.99	56.0	6.95	44.8	5.14	33.6	3.47		
15 °C	112.0	112.0	20.8	100.8	17.1	89.6	13.9	78.4	11.2	67.2	8.89	56.0	6.87	44.8	5.08	33.6	3.43		

TC : Total Capacity PI : Power Input
Indoor air temperature conditions : 27.0°C dry-bulb / 19.0°C wet bulb

Heating			Compressor + Outdoor Fan Power consumption (kW)																	
			Outdoor Unit		100%		90%		80%		70%		60%		50%		40%		30%	
			Dry-Bulb (°C)	Wet-Bulb (°C)	Capacity (kW)	TC (kW)	PI (kW)	Capacity (kW)	TC (kW)	PI (kW)	Capacity (kW)	TC (kW)	PI (kW)	Capacity (kW)	TC (kW)	PI (kW)	Capacity (kW)	TC (kW)	PI (kW)	Capacity (kW)
15.0	13.7	126.0	126.0	28.4	113.4	24.0	100.8	20.1	88.2	16.8	75.6	13.8	63.0	11.0	50.4	8.50	37.8	6.03		
13.0	11.8	126.0	126.0	29.6	113.4	24.9	100.8	20.9	88.2	17.3	75.6	14.2	63.0	11.4	50.4	8.74	37.8	6.21		
11.0	9.8	126.0	126.0	30.9	113.4	26.0	100.8	21.7	88.2	17.9	75.6	14.7	63.0	11.7	50.4	9.01	37.8	6.41		
9.0	7.9	126.0	126.0	32.4	113.4	27.1	100.8	22.5	88.2	18.6	75.6	15.2	63.0	12.1	50.4	9.28	37.8	6.61		
7.0	6.0	126.0	126.0	34.0	113.4	28.3	100.8	23.5	88.2	19.3	75.6	15.7	63.0	12.5	50.4	9.57	37.8	6.82		
5.0	4.1	121.5	121.5	33.7	109.3	28.1	97.2	23.3	85.0	19.2	72.9	15.6	60.7	12.4	48.6	9.50	36.4	6.77		
3.0	2.2	117.0	117.0	33.5	105.3	27.9	93.6	23.1	81.9	19.0	70.2	15.4	58.5	12.3	46.8	9.43	35.1	6.72		
0.0	-0.7	110.1	110.1	33.1	99.1	27.6	88.1	22.8	77.1	18.8	66.1	15.3	55.0	12.1	44.0	9.32	33.0	6.64		
-3.0	-3.7	103.0	103.0	32.7	92.7	27.2	82.4	22.6	72.1	18.5	61.8	15.1	51.5	12.0	41.2	9.20	30.9	6.56		
-5.0	-5.6	98.5	98.5	32.4	88.6	27.0	78.8	22.4	68.9	18.4	59.1	15.0	49.2	11.9	39.4	9.13	29.5	6.50		
-7.0	-7.6	93.7	93.7	32.1	84.3	26.8	75.0	22.2	65.6	18.2	56.2	14.8	46.9	11.8	37.5	9.05	28.1	6.45		
-10	-10.5	86.8	86.8	31.8	78.1	26.5	69.5	21.9	60.8	18.0	52.1	14.6	43.4	11.7	34.7	8.94	26.0	6.37		
-14.5	-15.0	76.1	76.1	31.1	68.5	25.9	60.9	21.5	53.3	17.7	45.7	14.4	38.1	11.4	30.5	8.77	22.8	6.25		

TC : Total Capacity PI : Power Input
Indoor air temperature conditions : 20.0°C dry-bulb



MMY-AP4216HT8P-E (42HP, 117kW system)

Cooling

Outdoor Unit (°C)		Outdoor Unit 100% Capacity (kW)	Compressor + Outdoor Fan Power consumption (kW)															
			100%		90%		80%		70%		60%		50%		40%		30%	
			TC (kW)	PI (kW)	TC (kW)	PI (kW)	TC (kW)	PI (kW)	TC (kW)	PI (kW)	TC (kW)	PI (kW)	TC (kW)	PI (kW)	TC (kW)	PI (kW)	TC (kW)	PI (kW)
40 °C		109.4	109.4	43.8	98.4	34.8	87.5	27.2	76.5	21.0	65.6	16.0	54.7	11.8	43.7	8.49	32.8	5.71
39 °C		111.1	111.1	43.1	100.0	34.2	88.9	26.8	77.8	20.7	66.7	15.7	55.6	11.7	44.4	8.36	33.3	5.63
37 °C		114.4	114.4	41.8	103.0	33.2	91.5	26.0	80.1	20.1	68.7	15.3	57.2	11.3	45.8	8.11	34.3	5.45
35 °C		117.5	117.5	40.5	105.7	32.2	94.0	25.2	82.2	19.5	70.5	14.8	58.7	11.0	47.0	7.85	35.2	5.28
33 °C		117.5	117.5	37.1	105.8	29.6	94.0	23.3	82.3	18.0	70.5	13.7	58.8	10.2	47.0	7.34	35.3	4.95
31 °C		117.5	117.5	34.2	105.8	27.3	94.0	21.5	82.3	16.7	70.5	12.8	58.8	9.54	47.0	6.88	35.3	4.64
30 °C		117.5	117.5	32.9	105.8	26.3	94.0	20.7	82.3	16.1	70.5	12.4	58.8	9.23	47.0	6.66	35.3	4.50
29 °C		117.5	117.5	31.6	105.8	25.3	94.0	20.0	82.3	15.6	70.5	11.9	58.8	8.94	47.0	6.45	35.3	4.36
27 °C		117.5	117.5	29.3	105.8	23.5	94.0	18.6	82.3	14.5	70.5	11.2	58.8	8.38	47.0	6.06	35.3	4.11
25 °C		117.5	117.5	27.3	105.8	21.9	94.0	17.4	82.3	13.6	70.5	10.5	58.8	7.86	47.0	5.70	35.3	3.86
23 °C		117.5	117.5	25.9	105.8	20.9	94.0	16.6	82.3	13.0	70.5	10.0	58.8	7.54	47.0	5.47	35.3	3.71
21 °C		117.5	117.5	25.3	105.8	20.4	94.0	16.2	82.3	12.7	70.5	9.82	58.8	7.41	47.0	5.39	35.3	3.66
20 °C		117.5	117.5	25.0	105.8	20.1	94.0	16.0	82.3	12.6	70.5	9.74	58.8	7.35	47.0	5.35	35.3	3.63
19 °C		117.5	117.5	24.7	105.8	19.9	94.0	15.9	82.3	12.5	70.5	9.66	58.8	7.30	47.0	5.31	35.3	3.61
17 °C		117.5	117.5	24.3	105.8	19.6	94.0	15.6	82.3	12.3	70.5	9.52	58.8	7.20	47.0	5.24	35.3	3.56
15 °C		117.5	117.5	23.9	105.8	19.3	94.0	15.4	82.3	12.1	70.5	9.40	58.8	7.11	47.0	5.19	35.3	3.53

TC : Total Capacity PI : Power Input
 Indoor air temperature conditions : 27.0°C dry-bulb / 19.0°C wet bulb

Heating

Outdoor Unit Dry-Bulb / Wet-Bulb (°C) / (°C)		Outdoor Unit 100% Heating Capacity (kW)	Compressor + Outdoor Fan Power consumption (kW)															
			100% Capacity		90% Capacity		80% Capacity		70% Capacity		60% Capacity		50% Capacity		40% Capacity		30% Capacity	
			TC (kW)	PI (kW)	TC (kW)	PI (kW)	TC (kW)	PI (kW)	TC (kW)	PI (kW)	TC (kW)	PI (kW)	TC (kW)	PI (kW)	TC (kW)	PI (kW)	TC (kW)	PI (kW)
15.0	13.7	127.0	127.0	29.8	114.3	25.2	101.6	21.1	88.9	17.6	76.2	14.5	63.5	11.7	50.8	9.01	38.1	6.39
13.0	11.8	127.0	127.0	31.1	114.3	26.1	101.6	21.9	88.9	18.2	76.2	15.0	63.5	12.0	50.8	9.27	38.1	6.58
11.0	9.8	127.0	127.0	32.5	114.3	27.3	101.6	22.8	88.9	18.9	76.2	15.5	63.5	12.4	50.8	9.55	38.1	6.79
9.0	7.9	127.0	127.0	34.1	114.3	28.5	101.6	23.7	88.9	19.5	76.2	16.0	63.5	12.8	50.8	9.84	38.1	7.01
7.0	6.0	127.0	127.0	35.8	114.3	29.8	101.6	24.6	88.9	20.3	76.2	16.5	63.5	13.2	50.8	10.1	38.1	7.23
5.0	4.1	122.4	122.4	35.5	110.2	29.5	98.0	24.4	85.7	20.1	73.5	16.4	61.2	13.1	49.0	10.1	36.7	7.18
3.0	2.2	117.9	117.9	35.3	106.1	29.3	94.3	24.3	82.5	20.0	70.7	16.3	59.0	13.0	47.2	9.99	35.4	7.12
0.0	-0.7	111.0	111.0	34.8	99.9	29.0	88.8	24.0	77.7	19.7	66.6	16.1	55.5	12.8	44.4	9.87	33.3	7.04
-3.0	-3.7	103.8	103.8	34.4	93.4	28.6	83.0	23.7	72.6	19.5	62.3	15.9	51.9	12.7	41.5	9.75	31.1	6.95
-5.0	-5.6	99.2	99.2	34.1	89.3	28.4	79.4	23.5	69.5	19.3	59.5	15.7	49.6	12.6	39.7	9.67	29.8	6.90
-7.0	-7.6	94.4	94.4	33.8	85.0	28.1	75.6	23.3	66.1	19.2	56.7	15.6	47.2	12.5	37.8	9.59	28.3	6.84
-10	-10.5	87.5	87.5	33.4	78.8	27.8	70.0	23.0	61.3	18.9	52.5	15.4	43.8	12.3	35.0	9.47	26.3	6.76
-14.5	-15.0	76.7	76.7	32.8	69.1	27.3	61.4	22.6	53.7	18.6	46.0	15.1	38.4	12.1	30.7	9.29	23.0	6.63

TC : Total Capacity PI : Power Input
 Indoor air temperature conditions : 20.0°C dry-bulb



MMY-AP4416HT8P-E (44HP, 123kW system)

Cooling

Outdoor Unit (°C)		Outdoor Unit 100% Capacity (kW)	Compressor + Outdoor Fan Power consumption (kW)															
			100%		90%		80%		70%		60%		50%		40%		30%	
			TC (kW)	PI (kW)	TC (kW)	PI (kW)	TC (kW)	PI (kW)	TC (kW)	PI (kW)	TC (kW)	PI (kW)	TC (kW)	PI (kW)	TC (kW)	PI (kW)	TC (kW)	PI (kW)
40 °C		114.5	50.1	103.0	39.4	91.6	30.5	80.1	23.1	68.7	17.2	57.2	12.4	45.8	8.72	34.3	5.82	
39 °C		116.3	49.4	104.7	38.8	93.0	30.0	81.4	22.8	69.8	16.9	58.2	12.3	46.5	8.59	34.9	5.73	
37 °C		119.8	47.9	107.8	37.6	95.8	29.1	83.8	22.1	71.9	16.4	59.9	11.9	47.9	8.33	35.9	5.56	
35 °C		123.0	46.4	110.7	36.5	98.4	28.2	86.1	21.4	73.8	15.9	61.5	11.5	49.2	8.07	36.9	5.38	
33 °C		123.0	42.5	110.7	33.4	98.4	25.9	86.1	19.7	73.8	14.7	61.5	10.7	49.2	7.53	36.9	5.05	
31 °C		123.0	39.0	110.7	30.8	98.4	23.9	86.1	18.3	73.8	13.7	61.5	9.97	49.2	7.04	36.9	4.74	
30 °C		123.0	37.5	110.7	29.6	98.4	23.0	86.1	17.6	73.8	13.2	61.5	9.63	49.2	6.82	36.9	4.59	
29 °C		123.0	36.0	110.7	28.5	98.4	22.2	86.1	17.0	73.8	12.7	61.5	9.31	49.2	6.60	36.9	4.46	
27 °C		123.0	33.3	110.7	26.4	98.4	20.6	86.1	15.8	73.8	11.9	61.5	8.72	49.2	6.20	36.9	4.19	
25 °C		123.0	30.9	110.7	24.5	98.4	19.2	86.1	14.7	73.8	11.1	61.5	8.17	49.2	5.82	36.9	3.95	
23 °C		123.0	29.4	110.7	23.3	98.4	18.3	86.1	14.1	73.8	10.6	61.5	7.82	49.2	5.59	36.9	3.80	
21 °C		123.0	28.6	110.7	22.8	98.4	17.8	86.1	13.7	73.8	10.39	61.5	7.68	49.2	5.50	36.9	3.75	
20 °C		123.0	28.3	110.7	22.5	98.4	17.6	86.1	13.6	73.8	10.30	61.5	7.61	49.2	5.45	36.9	3.72	
19 °C		123.0	28.0	110.7	22.3	98.4	17.5	86.1	13.5	73.8	10.21	61.5	7.55	49.2	5.42	36.9	3.70	
17 °C		123.0	27.4	110.7	21.8	98.4	17.1	86.1	13.2	73.8	10.05	61.5	7.45	49.2	5.35	36.9	3.65	
15 °C		123.0	26.9	110.7	21.5	98.4	16.9	86.1	13.1	73.8	9.91	61.5	7.35	49.2	5.29	36.9	3.62	

TC : Total Capacity PI : Power Input
Indoor air temperature conditions : 27.0°C dry-bulb / 19.0°C wet bulb

Heating

Outdoor Unit Dry-Bulb (°C) / Wet-Bulb (°C)		Outdoor Unit 100% Heating Capacity (kW)	Compressor + Outdoor Fan Power consumption (kW)															
			100% Capacity		90% Capacity		80% Capacity		70% Capacity		60% Capacity		50% Capacity		40% Capacity		30% Capacity	
			TC (kW)	PI (kW)	TC (kW)	PI (kW)	TC (kW)	PI (kW)	TC (kW)	PI (kW)	TC (kW)	PI (kW)	TC (kW)	PI (kW)	TC (kW)	PI (kW)	TC (kW)	PI (kW)
15.0	13.7	128.0	128.0	31.2	115.2	26.4	102.4	22.2	89.6	18.5	76.8	15.3	64.0	12.3	51.2	9.53	38.4	6.75
13.0	11.8	128.0	128.0	32.6	115.2	27.4	102.4	22.9	89.6	19.1	76.8	15.7	64.0	12.7	51.2	9.80	38.4	6.95
11.0	9.8	128.0	128.0	34.1	115.2	28.6	102.4	23.8	89.6	19.8	76.8	16.2	64.0	13.1	51.2	10.1	38.4	7.18
9.0	7.9	128.0	128.0	35.8	115.2	29.8	102.4	24.8	89.6	20.5	76.8	16.8	64.0	13.5	51.2	10.4	38.4	7.41
7.0	6.0	128.0	128.0	37.6	115.2	31.2	102.4	25.8	89.6	21.2	76.8	17.3	64.0	13.9	51.2	10.7	38.4	7.65
5.0	4.1	123.4	123.4	37.3	111.1	31.0	98.7	25.6	86.4	21.1	74.0	17.2	61.7	13.8	49.4	10.6	37.0	7.59
3.0	2.2	118.8	118.8	37.0	106.9	30.7	95.1	25.4	83.2	20.9	71.3	17.1	59.4	13.7	47.5	10.6	35.6	7.53
0.0	-0.7	111.8	111.8	36.6	100.7	30.4	89.5	25.1	78.3	20.7	67.1	16.9	55.9	13.5	44.7	10.4	33.6	7.44
-3.0	-3.7	104.6	104.6	36.1	94.1	30.0	83.7	24.8	73.2	20.4	62.8	16.7	52.3	13.3	41.8	10.3	31.4	7.35
-5.0	-5.6	100.0	100.0	35.9	90.0	29.7	80.0	24.6	70.0	20.3	60.0	16.5	50.0	13.2	40.0	10.2	30.0	7.29
-7.0	-7.6	95.2	95.2	35.6	85.7	29.5	76.2	24.4	66.6	20.1	57.1	16.4	47.6	13.1	38.1	10.1	28.6	7.23
-10	-10.5	88.2	88.2	35.1	79.4	29.1	70.6	24.1	61.7	19.8	52.9	16.2	44.1	13.0	35.3	10.0	26.5	7.14
-14.5	-15.0	77.3	77.3	34.4	69.6	28.6	61.9	23.6	54.1	19.5	46.4	15.9	38.7	12.7	30.9	9.82	23.2	7.01

TC : Total Capacity PI : Power Input
Indoor air temperature conditions : 20.0°C dry-bulb



MMY-AP4616HT8P-E (46HP, 130kW system)

Cooling		Compressor + Outdoor Fan Power consumption (kW)																	
		Outdoor Unit		100%		90%		80%		70%		60%		50%		40%		30%	
		(°C)	Unit 100% Capacity (kW)	TC (kW)	PI (kW)	TC (kW)	PI (kW)	TC (kW)	PI (kW)	TC (kW)	PI (kW)	TC (kW)	PI (kW)	TC (kW)	PI (kW)	TC (kW)	PI (kW)	TC (kW)	PI (kW)
40 °C	121.0	121.0	44.2	108.9	35.1	96.8	27.6	84.7	21.5	72.6	16.5	60.5	12.4	48.4	9.03	36.3	6.10		
39 °C	122.9	122.9	43.5	110.6	34.6	98.3	27.2	86.0	21.2	73.8	16.2	61.5	12.2	49.2	8.89	36.9	6.01		
37 °C	126.6	126.6	42.2	113.9	33.5	101.3	26.4	88.6	20.5	76.0	15.8	63.3	11.9	50.6	8.62	38.0	5.83		
35 °C	130.0	130.0	40.9	117.0	32.5	104.0	25.5	91.0	19.9	78.0	15.3	65.0	11.5	52.0	8.35	39.0	5.65		
33 °C	130.0	130.0	37.5	117.0	29.9	104.0	23.6	91.0	18.4	78.0	14.2	65.0	10.7	52.0	7.82	39.0	5.29		
31 °C	130.0	130.0	34.5	117.0	27.6	104.0	21.9	91.0	17.1	78.0	13.2	65.0	10.0	52.0	7.33	39.0	4.96		
30 °C	130.0	130.0	33.2	117.0	26.6	104.0	21.1	91.0	16.5	78.0	12.8	65.0	9.71	52.0	7.10	39.0	4.80		
29 °C	130.0	130.0	31.9	117.0	25.6	104.0	20.3	91.0	16.0	78.0	12.4	65.0	9.41	52.0	6.88	39.0	4.66		
27 °C	130.0	130.0	29.6	117.0	23.8	104.0	18.9	91.0	14.9	78.0	11.6	65.0	8.83	52.0	6.47	39.0	4.38		
25 °C	130.0	130.0	27.5	117.0	22.2	104.0	17.7	91.0	14.0	78.0	10.9	65.0	8.30	52.0	6.08	39.0	4.11		
23 °C	130.0	130.0	26.2	117.0	21.1	104.0	16.9	91.0	13.4	78.0	10.4	65.0	7.97	52.0	5.85	39.0	3.95		
21 °C	130.0	130.0	25.5	117.0	20.6	104.0	16.5	91.0	13.1	78.0	10.2	65.0	7.83	52.0	5.75	39.0	3.89		
20 °C	130.0	130.0	25.3	117.0	20.4	104.0	16.4	91.0	13.0	78.0	10.2	65.0	7.77	52.0	5.71	39.0	3.86		
19 °C	130.0	130.0	25.0	117.0	20.2	104.0	16.2	91.0	12.9	78.0	10.1	65.0	7.72	52.0	5.67	39.0	3.83		
17 °C	130.0	130.0	24.5	117.0	19.9	104.0	16.0	91.0	12.7	78.0	9.94	65.0	7.62	52.0	5.60	39.0	3.78		
15 °C	130.0	130.0	24.1	117.0	19.6	104.0	15.7	91.0	12.5	78.0	9.82	65.0	7.53	52.0	5.54	39.0	3.74		

TC : Total Capacity PI : Power Input
Indoor air temperature conditions : 27.0°C dry-bulb / 19.0°C wet bulb

Heating			Compressor + Outdoor Fan Power consumption (kW)																	
			Outdoor Unit		100%		90%		80%		70%		60%		50%		40%		30%	
			Dry-Bulb (°C)	Wet-Bulb (°C)	Heating Capacity (kW)	TC (kW)	PI (kW)	TC (kW)	PI (kW)	TC (kW)	PI (kW)	TC (kW)	PI (kW)	TC (kW)	PI (kW)	TC (kW)	PI (kW)	TC (kW)	PI (kW)	
15.0	13.7	145.0	145.0	30.3	130.5	25.1	116.0	20.8	101.5	17.2	87.0	14.2	72.5	11.6	58.0	9.42	43.5	7.53		
13.0	11.8	145.0	145.0	31.7	130.5	26.2	116.0	21.6	101.5	17.8	87.0	14.6	72.5	11.9	58.0	9.61	43.5	7.66		
11.0	9.8	145.0	145.0	33.3	130.5	27.5	116.0	22.6	101.5	18.4	87.0	15.0	72.5	12.2	58.0	9.82	43.5	7.79		
9.0	7.9	145.0	145.0	35.1	130.5	28.8	116.0	23.5	101.5	19.1	87.0	15.5	72.5	12.5	58.0	10.0	43.5	7.93		
7.0	6.0	145.0	145.0	37.0	130.5	30.2	116.0	24.6	101.5	19.9	87.0	16.1	72.5	12.9	58.0	10.3	43.5	8.08		
5.0	4.1	140.0	140.0	36.7	126.0	30.0	112.0	24.4	98.0	19.8	84.0	15.9	70.0	12.8	56.0	10.2	42.0	8.02		
3.0	2.2	134.9	134.9	36.5	121.4	29.8	108.0	24.3	94.5	19.6	81.0	15.8	67.5	12.7	54.0	10.1	40.5	7.96		
0.0	-0.7	127.3	127.3	36.1	114.5	29.5	101.8	24.0	89.1	19.4	76.4	15.7	63.6	12.6	50.9	10.0	38.2	7.88		
-3.0	-3.7	119.3	119.3	35.7	107.4	29.2	95.5	23.7	83.5	19.2	71.6	15.5	59.7	12.4	47.7	9.91	35.8	7.79		
-5.0	-5.6	114.3	114.3	35.4	102.9	28.9	91.4	23.5	80.0	19.1	68.6	15.4	57.1	12.3	45.7	9.84	34.3	7.73		
-7.0	-7.6	109.0	109.0	35.1	98.1	28.7	87.2	23.4	76.3	18.9	65.4	15.3	54.5	12.2	43.6	9.76	32.7	7.67		
-10	-10.5	101.3	101.3	34.7	91.2	28.4	81.1	23.1	70.9	18.7	60.8	15.1	50.7	12.1	40.5	9.65	30.4	7.59		
-14.5	-15.0	89.4	89.4	34.1	80.5	27.9	71.5	22.7	62.6	18.4	53.7	14.8	44.7	11.9	35.8	9.48	26.8	7.45		

TC : Total Capacity PI : Power Input
Indoor air temperature conditions : 20.0°C dry-bulb



MMY-AP4816HT8P (48HP, 135kW system)

Cooling			Compressor + Outdoor Fan Power consumption (kW)															
Outdoor Unit (°C)	Outdoor Unit 100% Capacity (kW)	100%		90%		80%		70%		60%		50%		40%		30%		
		TC	PI	TC	PI	TC	PI	TC	PI	TC	PI	TC	PI	TC	PI	TC	PI	
		(kW)	(kW)	(kW)	(kW)	(kW)	(kW)	(kW)	(kW)	(kW)	(kW)	(kW)	(kW)	(kW)	(kW)	(kW)	(kW)	(kW)
40 °C	125.6	125.6	46.3	113.1	36.9	100.5	29.1	87.9	22.6	75.4	17.3	62.8	12.9	50.3	9.31	37.7	6.23	
39 °C	127.7	127.7	45.7	114.9	36.4	102.1	28.7	89.4	22.3	76.6	17.0	63.8	12.7	51.1	9.17	38.3	6.14	
37 °C	131.5	131.5	44.3	118.3	35.3	105.2	27.8	92.0	21.6	78.9	16.5	65.7	12.4	52.6	8.89	39.4	5.95	
35 °C	135.0	135.0	42.9	121.5	34.2	108.0	26.9	94.5	20.9	81.0	16.0	67.5	12.0	54.0	8.61	40.5	5.76	
33 °C	135.0	135.0	39.4	121.5	31.5	108.0	24.9	94.5	19.4	81.0	14.9	67.5	11.2	54.0	8.05	40.5	5.39	
31 °C	135.0	135.0	36.3	121.5	29.1	108.0	23.0	94.5	18.0	81.0	13.9	67.5	10.4	54.0	7.54	40.5	5.05	
30 °C	135.0	135.0	34.9	121.5	28.0	108.0	22.2	94.5	17.4	81.0	13.4	67.5	10.1	54.0	7.31	40.5	4.90	
29 °C	135.0	135.0	33.6	121.5	27.0	108.0	21.4	94.5	16.8	81.0	13.0	67.5	9.77	54.0	7.08	40.5	4.74	
27 °C	135.0	135.0	31.1	121.5	25.1	108.0	20.0	94.5	15.7	81.0	12.1	67.5	9.17	54.0	6.65	40.5	4.46	
25 °C	135.0	135.0	29.0	121.5	23.4	108.0	18.6	94.5	14.7	81.0	11.4	67.5	8.60	54.0	6.25	40.5	4.19	
23 °C	135.0	135.0	27.6	121.5	22.3	108.0	17.8	94.5	14.0	81.0	10.9	67.5	8.26	54.0	6.00	40.5	4.03	
21 °C	135.0	135.0	26.9	121.5	21.7	108.0	17.4	94.5	13.8	81.0	10.7	67.5	8.12	54.0	5.90	40.5	3.96	
20 °C	135.0	135.0	26.6	121.5	21.5	108.0	17.2	94.5	13.6	81.0	10.6	67.5	8.05	54.0	5.86	40.5	3.93	
19 °C	135.0	135.0	26.3	121.5	21.3	108.0	17.1	94.5	13.5	81.0	10.5	67.5	7.99	54.0	5.82	40.5	3.90	
17 °C	135.0	135.0	25.8	121.5	20.9	108.0	16.8	94.5	13.3	81.0	10.4	67.5	7.89	54.0	5.75	40.5	3.85	
15 °C	135.0	135.0	25.4	121.5	20.6	108.0	16.6	94.5	13.1	81.0	10.2	67.5	7.80	54.0	5.68	40.5	3.81	

TC : Total Capacity PI : Power Input
Indoor air temperature conditions : 27.0°C dry-bulb / 19.0°C wet bulb

Heating			Compressor + Outdoor Fan Power consumption (kW)																
Outdoor Unit Dry-Bulb (°C)	Outdoor Unit Wet-Bulb (°C)	Outdoor Unit 100% Heating Capacity (kW)	100%		90%		80%		70%		60%		50%		40%		30%		
			Capacity	Capacity	Capacity	Capacity	Capacity	Capacity	Capacity	Capacity	Capacity	Capacity	Capacity	Capacity	Capacity	Capacity	Capacity		
			TC	PI	TC	PI	TC	PI	TC	PI	TC	PI	TC	PI	TC	PI	TC	PI	TC
(kW)	(kW)	(kW)	(kW)	(kW)	(kW)	(kW)	(kW)	(kW)	(kW)	(kW)	(kW)	(kW)	(kW)	(kW)	(kW)	(kW)	(kW)	(kW)	(kW)
15.0	13.7	150.0	150.0	31.8	135.0	26.5	120.0	22.0	105.0	18.1	90.0	14.8	75.0	12.1	60.0	9.79	45.0	7.84	
13.0	11.8	150.0	150.0	33.3	135.0	27.6	120.0	22.8	105.0	18.7	90.0	15.3	75.0	12.4	60.0	9.99	45.0	7.96	
11.0	9.8	150.0	150.0	35.0	135.0	28.9	120.0	23.8	105.0	19.4	90.0	15.8	75.0	12.7	60.0	10.2	45.0	8.10	
9.0	7.9	150.0	150.0	36.7	135.0	30.3	120.0	24.8	105.0	20.2	90.0	16.3	75.0	13.1	60.0	10.5	45.0	8.24	
7.0	6.0	150.0	150.0	38.7	135.0	31.8	120.0	25.9	105.0	21.0	90.0	16.9	75.0	13.5	60.0	10.7	45.0	8.40	
5.0	4.1	144.6	144.6	38.4	130.2	31.5	115.7	25.7	101.2	20.8	86.8	16.8	72.3	13.4	57.9	10.6	43.4	8.33	
3.0	2.2	139.3	139.3	38.1	125.3	31.3	111.4	25.5	97.5	20.7	83.6	16.6	69.6	13.3	55.7	10.5	41.8	8.27	
0.0	-0.7	131.1	131.1	37.7	118.0	30.9	104.8	25.2	91.7	20.4	78.6	16.4	65.5	13.1	52.4	10.4	39.3	8.17	
-3.0	-3.7	122.6	122.6	37.2	110.3	30.6	98.1	24.9	85.8	20.2	73.5	16.2	61.3	13.0	49.0	10.3	36.8	8.07	
-5.0	-5.6	117.2	117.2	36.9	105.5	30.3	93.8	24.7	82.0	20.0	70.3	16.1	58.6	12.9	46.9	10.2	35.2	8.01	
-7.0	-7.6	111.6	111.6	36.6	100.4	30.1	89.2	24.5	78.1	19.9	66.9	16.0	55.8	12.8	44.6	10.1	33.5	7.94	
-10	-10.5	103.4	103.4	36.1	93.0	29.7	82.7	24.2	72.3	19.6	62.0	15.8	51.7	12.6	41.3	10.00	31.0	7.84	
-14.5	-15.0	90.6	90.6	35.4	81.6	29.1	72.5	23.7	63.4	19.2	54.4	15.5	45.3	12.4	36.3	9.80	27.2	7.69	

TC : Total Capacity PI : Power Input
Indoor air temperature conditions : 20.0°C dry-bulb



MMY-AP5016HT8P-E (50HP, 140.4kW system)

Cooling		Compressor + Outdoor Fan Power consumption (kW)																	
		Outdoor Unit		100%		90%		80%		70%		60%		50%		40%		30%	
		(°C)	Capacity (kW)	TC (kW)	PI (kW)	TC (kW)	PI (kW)	TC (kW)	PI (kW)	TC (kW)	PI (kW)	TC (kW)	PI (kW)	TC (kW)	PI (kW)	TC (kW)	PI (kW)	TC (kW)	PI (kW)
40 °C	130.7	130.7	46.7	117.6	37.4	104.5	29.7	91.5	23.2	78.4	18.0	65.3	13.6	52.3	9.89	39.2	6.70		
39 °C	132.8	132.8	46.0	119.5	36.8	106.2	29.2	92.9	22.9	79.7	17.7	66.4	13.4	53.1	9.75	39.8	6.60		
37 °C	136.7	136.7	44.6	123.1	35.7	109.4	28.3	95.7	22.2	82.0	17.2	68.4	13.0	54.7	9.45	41.0	6.40		
35 °C	140.4	140.4	43.2	126.3	34.6	112.3	27.4	98.3	21.5	84.2	16.6	70.2	12.6	56.2	9.15	42.1	6.19		
33 °C	140.4	140.4	39.7	126.4	31.9	112.3	25.4	98.3	20.0	84.2	15.5	70.2	11.7	56.2	8.57	42.1	5.80		
31 °C	140.4	140.4	36.6	126.4	29.5	112.3	23.6	98.3	18.6	84.2	14.4	70.2	11.0	56.2	8.03	42.1	5.44		
30 °C	140.4	140.4	35.2	126.4	28.4	112.3	22.7	98.3	17.9	84.2	14.0	70.2	10.6	56.2	7.78	42.1	5.27		
29 °C	140.4	140.4	33.9	126.4	27.4	112.3	21.9	98.3	17.3	84.2	13.5	70.2	10.3	56.2	7.54	42.1	5.11		
27 °C	140.4	140.4	31.5	126.4	25.5	112.3	20.4	98.3	16.2	84.2	12.7	70.2	9.67	56.2	7.09	42.1	4.80		
25 °C	140.4	140.4	29.3	126.4	23.8	112.3	19.1	98.3	15.2	84.2	11.9	70.2	9.08	56.2	6.67	42.1	4.52		
23 °C	140.4	140.4	27.9	126.4	22.7	112.3	18.3	98.3	14.5	84.2	11.4	70.2	8.72	56.2	6.41	42.1	4.34		
21 °C	140.4	140.4	27.2	126.4	22.2	112.3	17.9	98.3	14.3	84.2	11.2	70.2	8.58	56.2	6.31	42.1	4.27		
20 °C	140.4	140.4	27.0	126.4	21.9	112.3	17.7	98.3	14.1	84.2	11.1	70.2	8.51	56.2	6.26	42.1	4.24		
19 °C	140.4	140.4	26.7	126.4	21.7	112.3	17.6	98.3	14.0	84.2	11.0	70.2	8.45	56.2	6.22	42.1	4.21		
17 °C	140.4	140.4	26.2	126.4	21.4	112.3	17.3	98.3	13.8	84.2	10.9	70.2	8.35	56.2	6.14	42.1	4.16		
15 °C	140.4	140.4	25.8	126.4	21.1	112.3	17.0	98.3	13.6	84.2	10.74	70.2	8.25	56.2	6.08	42.1	4.11		

TC : Total Capacity PI : Power Input
 Indoor air temperature conditions : 27.0°C dry-bulb / 19.0°C wet bulb

Heating			Compressor + Outdoor Fan Power consumption (kW)																	
			Outdoor Unit		100%		90%		80%		70%		60%		50%		40%		30%	
			Dry-Bulb (°C)	Wet-Bulb (°C)	Capacity (kW)	Capacity (kW)	Capacity (kW)	Capacity (kW)	Capacity (kW)	Capacity (kW)	Capacity (kW)	Capacity (kW)	Capacity (kW)	Capacity (kW)	Capacity (kW)	Capacity (kW)	Capacity (kW)	Capacity (kW)	Capacity (kW)	Capacity (kW)
15.0	13.7	156.0	156.0	32.9	140.4	27.6	124.8	22.9	109.2	19.0	93.6	15.6	78.0	12.7	62.4	10.1	46.8	7.88		
13.0	11.8	156.0	156.0	34.4	140.4	28.7	124.8	23.8	109.2	19.6	93.6	16.1	78.0	13.0	62.4	10.4	46.8	8.03		
11.0	9.8	156.0	156.0	36.1	140.4	30.0	124.8	24.8	109.2	20.4	93.6	16.6	78.0	13.4	62.4	10.6	46.8	8.20		
9.0	7.9	156.0	156.0	37.9	140.4	31.4	124.8	25.8	109.2	21.1	93.6	17.1	78.0	13.8	62.4	10.9	46.8	8.37		
7.0	6.0	156.0	156.0	39.9	140.4	32.9	124.8	27.0	109.2	22.0	93.6	17.7	78.0	14.2	62.4	11.2	46.8	8.55		
5.0	4.1	150.6	150.6	39.6	135.6	32.7	120.5	26.8	105.4	21.8	90.4	17.6	75.3	14.1	60.2	11.1	45.2	8.49		
3.0	2.2	145.2	145.2	39.3	130.7	32.5	116.2	26.6	101.7	21.7	87.1	17.5	72.6	14.0	58.1	11.0	43.6	8.43		
0.0	-0.7	137.0	137.0	38.9	123.3	32.1	109.6	26.3	95.9	21.4	82.2	17.3	68.5	13.8	54.8	10.9	41.1	8.34		
-3.0	-3.7	128.5	128.5	38.5	115.7	31.7	102.8	26.0	90.0	21.2	77.1	17.1	64.3	13.7	51.4	10.8	38.6	8.24		
-5.0	-5.6	123.1	123.1	38.2	110.8	31.5	98.5	25.8	86.2	21.0	73.9	17.0	61.6	13.6	49.3	10.7	36.9	8.18		
-7.0	-7.6	117.5	117.5	37.9	105.7	31.3	94.0	25.6	82.2	20.9	70.5	16.9	58.7	13.5	47.0	10.6	35.2	8.12		
-10	-10.5	109.3	109.3	37.5	98.3	30.9	87.4	25.4	76.5	20.6	65.6	16.7	54.6	13.3	43.7	10.5	32.8	8.03		
-14.5	-15.0	96.5	96.5	36.8	86.9	30.4	77.2	24.9	67.6	20.3	57.9	16.4	48.3	13.1	38.6	10.3	29.0	7.89		

TC : Total Capacity PI : Power Input
 Indoor air temperature conditions : 20.0°C dry-bulb



MMY-AP5216HT8P-E (52HP, 146kW system)

Outdoor Unit (°C)		Outdoor Unit 100% Capacity (kW)	Compressor + Outdoor Fan Power consumption (kW)															
			100%		90%		80%		70%		60%		50%		40%		30%	
			TC (kW)	PI (kW)	TC (kW)	PI (kW)	TC (kW)	PI (kW)	TC (kW)	PI (kW)	TC (kW)	PI (kW)	TC (kW)	PI (kW)	TC (kW)	PI (kW)	TC (kW)	PI (kW)
40 °C	135.9	135.9	49.6	122.3	39.7	108.7	31.4	95.1	24.6	81.5	18.9	67.9	14.2	54.3	10.3	40.8	6.95	
39 °C	138.1	138.1	48.9	124.3	39.1	110.4	30.9	96.6	24.2	82.8	18.6	69.0	14.0	55.2	10.2	41.4	6.85	
37 °C	142.2	142.2	47.4	128.0	37.9	113.7	30.0	99.5	23.5	85.3	18.1	71.1	13.6	56.9	9.87	42.7	6.64	
35 °C	146.0	146.0	45.9	131.4	36.7	116.8	29.1	102.2	22.7	87.6	17.5	73.0	13.2	58.4	9.56	43.8	6.43	
33 °C	146.0	146.0	42.2	131.4	33.8	116.8	26.9	102.2	21.1	87.6	16.3	73.0	12.3	58.4	8.95	43.8	6.02	
31 °C	146.0	146.0	38.9	131.4	31.3	116.8	24.9	102.2	19.6	87.6	15.2	73.0	11.5	58.4	8.38	43.8	5.65	
30 °C	146.0	146.0	37.4	131.4	30.1	116.8	24.0	102.2	18.9	87.6	14.7	73.0	11.1	58.4	8.12	43.8	5.47	
29 °C	146.0	146.0	36.0	131.4	29.0	116.8	23.2	102.2	18.3	87.6	14.2	73.0	10.8	58.4	7.87	43.8	5.30	
27 °C	146.0	146.0	33.4	131.4	27.0	116.8	21.6	102.2	17.1	87.6	13.3	73.0	10.1	58.4	7.40	43.8	4.98	
25 °C	146.0	146.0	31.1	131.4	25.2	116.8	20.2	102.2	16.0	87.6	12.5	73.0	9.51	58.4	6.95	43.8	4.68	
23 °C	146.0	146.0	29.6	131.4	24.0	116.8	19.3	102.2	15.3	87.6	12.0	73.0	9.14	58.4	6.68	43.8	4.50	
21 °C	146.0	146.0	28.9	131.4	23.5	116.8	18.9	102.2	15.0	87.6	11.8	73.0	8.98	58.4	6.57	43.8	4.42	
20 °C	146.0	146.0	28.6	131.4	23.2	116.8	18.7	102.2	14.9	87.6	11.7	73.0	8.91	58.4	6.53	43.8	4.39	
19 °C	146.0	146.0	28.3	131.4	23.0	116.8	18.5	102.2	14.8	87.6	11.6	73.0	8.85	58.4	6.48	43.8	4.36	
17 °C	146.0	146.0	27.8	131.4	22.6	116.8	18.2	102.2	14.5	87.6	11.4	73.0	8.73	58.4	6.40	43.8	4.30	
15 °C	146.0	146.0	27.3	131.4	22.3	116.8	18.0	102.2	14.4	87.6	11.3	73.0	8.63	58.4	6.33	43.8	4.26	

TC : Total Capacity PI : Power Input
Indoor air temperature conditions : 27.0°C dry-bulb / 19.0°C wet bulb

Outdoor Unit Dry-Bulb (°C) Wet-Bulb (°C)			Outdoor Unit 100% Heating Capacity (kW)	Compressor + Outdoor Fan Power consumption (kW)															
				100% Capacity		90% Capacity		80% Capacity		70% Capacity		60% Capacity		50% Capacity		40% Capacity		30% Capacity	
				TC (kW)	PI (kW)	TC (kW)	PI (kW)	TC (kW)	PI (kW)	TC (kW)	PI (kW)	TC (kW)	PI (kW)	TC (kW)	PI (kW)	TC (kW)	PI (kW)	TC (kW)	PI (kW)
15.0	13.7	163.0	163.0	35.4	146.7	29.7	130.4	24.7	114.1	20.5	97.8	16.8	81.5	13.6	65.2	10.8	48.9	8.24	
13.0	11.8	163.0	163.0	37.0	146.7	30.9	130.4	25.6	114.1	21.1	97.8	17.3	81.5	14.0	65.2	11.0	48.9	8.42	
11.0	9.8	163.0	163.0	38.8	146.7	32.3	130.4	26.7	114.1	21.9	97.8	17.9	81.5	14.4	65.2	11.3	48.9	8.61	
9.0	7.9	163.0	163.0	40.7	146.7	33.7	130.4	27.8	114.1	22.8	97.8	18.5	81.5	14.8	65.2	11.6	48.9	8.80	
7.0	6.0	163.0	163.0	42.8	146.7	35.4	130.4	29.0	114.1	23.6	97.8	19.1	81.5	15.2	65.2	11.9	48.9	9.01	
5.0	4.1	157.2	157.2	42.5	141.4	35.1	125.7	28.8	110.0	23.5	94.3	19.0	78.6	15.1	62.9	11.8	47.1	8.94	
3.0	2.2	151.3	151.3	42.1	136.2	34.8	121.1	28.6	105.9	23.3	90.8	18.8	75.7	15.0	60.5	11.7	45.4	8.87	
0.0	-0.7	142.4	142.4	41.6	128.2	34.4	113.9	28.2	99.7	23.0	85.4	18.6	71.2	14.8	57.0	11.6	42.7	8.77	
-3.0	-3.7	133.2	133.2	41.1	119.9	34.0	106.6	27.9	93.2	22.7	79.9	18.4	66.6	14.6	53.3	11.5	40.0	8.66	
-5.0	-5.6	127.4	127.4	40.8	114.6	33.7	101.9	27.7	89.2	22.6	76.4	18.2	63.7	14.5	50.9	11.4	38.2	8.59	
-7.0	-7.6	121.2	121.2	40.5	109.1	33.4	97.0	27.4	84.9	22.4	72.7	18.1	60.6	14.4	48.5	11.3	36.4	8.52	
-10	-10.5	112.3	112.3	40.0	101.1	33.0	89.8	27.1	78.6	22.1	67.4	17.8	56.2	14.2	44.9	11.1	33.7	8.41	
-14.5	-15.0	98.5	98.5	39.2	88.6	32.4	78.8	26.6	68.9	21.7	59.1	17.5	49.2	14.0	39.4	10.9	29.5	8.25	

TC : Total Capacity PI : Power Input
Indoor air temperature conditions : 20.0°C dry-bulb



MMY-AP5616HT8P-E (56HP, 157.0kW system)

Cooling		Compressor + Outdoor Fan Power consumption (kW)																	
		Outdoor Unit		100%		90%		80%		70%		60%		50%		40%		30%	
		(°C)	Capacity (kW)	TC (kW)	PI (kW)	TC (kW)	PI (kW)	TC (kW)	PI (kW)	TC (kW)	PI (kW)	TC (kW)	PI (kW)	TC (kW)	PI (kW)	TC (kW)	PI (kW)	TC (kW)	PI (kW)
40 °C	146.1	146.1	52.8	131.5	42.4	116.9	33.7	102.3	26.5	87.7	20.5	73.1	15.6	58.4	11.4	43.8	7.68		
39 °C	148.5	148.5	52.0	133.6	41.8	118.8	33.2	103.9	26.1	89.1	20.2	74.2	15.3	59.4	11.2	44.5	7.56		
37 °C	152.9	152.9	50.5	137.6	40.5	122.3	32.2	107.0	25.3	91.7	19.6	76.4	14.9	61.2	10.9	45.9	7.34		
35 °C	157.0	157.0	48.9	141.3	39.2	125.6	31.2	109.9	24.5	94.2	19.0	78.5	14.4	62.8	10.51	47.1	7.10		
33 °C	157.0	157.0	44.9	141.3	36.2	125.6	28.9	109.9	22.8	94.2	17.7	78.5	13.5	62.8	9.84	47.1	6.65		
31 °C	157.0	157.0	41.5	141.3	33.5	125.6	26.8	109.9	21.2	94.2	16.5	78.5	12.60	62.8	9.22	47.1	6.24		
30 °C	157.0	157.0	39.9	141.3	32.3	125.6	25.9	109.9	20.5	94.2	16.0	78.5	12.20	62.8	8.94	47.1	6.04		
29 °C	157.0	157.0	38.4	141.3	31.1	125.6	25.0	109.9	19.8	94.2	15.5	78.5	11.81	62.8	8.66	47.1	5.86		
27 °C	157.0	157.0	35.7	141.3	29.0	125.6	23.3	109.9	18.5	94.2	14.5	78.5	11.09	62.8	8.14	47.1	5.50		
25 °C	157.0	157.0	33.2	141.3	27.0	125.6	21.8	109.9	17.3	94.2	13.6	78.5	10.42	62.8	7.66	47.1	5.17		
23 °C	157.0	157.0	31.7	141.3	25.8	125.6	20.8	109.9	16.6	94.2	13.1	78.5	10.01	62.8	7.36	47.1	4.97		
21 °C	157.0	157.0	30.9	141.3	25.2	125.6	20.4	109.9	16.3	94.2	12.8	78.5	9.85	62.8	7.24	47.1	4.89		
20 °C	157.0	157.0	30.6	141.3	25.0	125.6	20.2	109.9	16.1	94.2	12.7	78.5	9.77	62.8	7.19	47.1	4.85		
19 °C	157.0	157.0	30.3	141.3	24.7	125.6	20.0	109.9	16.0	94.2	12.6	78.5	9.70	62.8	7.14	47.1	4.82		
17 °C	157.0	157.0	29.7	141.3	24.3	125.6	19.7	109.9	15.8	94.2	12.5	78.5	9.58	62.8	7.05	47.1	4.76		
15 °C	157.0	157.0	29.3	141.3	24.0	125.6	19.4	109.9	15.6	94.2	12.3	78.5	9.47	62.8	6.98	47.1	4.70		

TC : Total Capacity PI : Power Input
Indoor air temperature conditions : 27.0°C dry-bulb / 19.0°C wet bulb

Heating			Compressor + Outdoor Fan Power consumption (kW)																	
			Outdoor Unit		100%		90%		80%		70%		60%		50%		40%		30%	
			Dry-Bulb (°C)	Wet-Bulb (°C)	Capacity (kW)	TC (kW)	PI (kW)	TC (kW)	PI (kW)	TC (kW)	PI (kW)	TC (kW)	PI (kW)	TC (kW)	PI (kW)	TC (kW)	PI (kW)	TC (kW)	PI (kW)	TC (kW)
15.0	13.7	176.0	176.0	39.0	158.4	32.8	140.8	27.5	123.2	22.8	105.6	18.7	88.0	15.1	70.4	11.8	52.8	8.65		
13.0	11.8	176.0	176.0	40.6	158.4	34.1	140.8	28.5	123.2	23.6	105.6	19.3	88.0	15.5	70.4	12.1	52.8	8.87		
11.0	9.8	176.0	176.0	42.6	158.4	35.6	140.8	29.6	123.2	24.4	105.6	19.9	88.0	16.0	70.4	12.4	52.8	9.11		
9.0	7.9	176.0	176.0	44.6	158.4	37.2	140.8	30.8	123.2	25.3	105.6	20.6	88.0	16.5	70.4	12.8	52.8	9.36		
7.0	6.0	176.0	176.0	46.9	158.4	38.9	140.8	32.1	123.2	26.3	105.6	21.3	88.0	17.0	70.4	13.1	52.8	9.62		
5.0	4.1	169.7	169.7	46.5	152.7	38.6	135.8	31.9	118.8	26.1	101.8	21.1	84.8	16.9	67.9	13.0	50.9	9.55		
3.0	2.2	163.4	163.4	46.2	147.1	38.3	130.7	31.6	114.4	25.9	98.0	21.0	81.7	16.7	65.4	12.9	49.0	9.47		
0.0	-0.7	153.8	153.8	45.6	138.4	37.9	123.0	31.3	107.6	25.6	92.3	20.7	76.9	16.5	61.5	12.8	46.1	9.36		
-3.0	-3.7	143.8	143.8	45.1	129.4	37.4	115.1	30.9	100.7	25.3	86.3	20.5	71.9	16.3	57.5	12.6	43.1	9.25		
-5.0	-5.6	137.5	137.5	44.7	123.8	37.1	110.0	30.6	96.3	25.1	82.5	20.3	68.8	16.2	55.0	12.5	41.3	9.17		
-7.0	-7.6	130.9	130.9	44.3	117.8	36.8	104.7	30.4	91.6	24.9	78.5	20.2	65.4	16.1	52.4	12.4	39.3	9.10		
-10	-10.5	121.3	121.3	43.8	109.1	36.4	97.0	30.0	84.9	24.6	72.8	19.9	60.6	15.9	48.5	12.3	36.4	8.99		
-14.5	-15.0	106.3	106.3	43.0	95.7	35.7	85.1	29.4	74.4	24.1	63.8	19.5	53.2	15.6	42.5	12.0	31.9	8.81		

TC : Total Capacity PI : Power Input
Indoor air temperature conditions : 20.0°C dry-bulb



MMY-AP5816HT8P-E (58HP, 162.5kW system)

Cooling		Outdoor Unit 100% Capacity (kW)	Compressor + Outdoor Fan Power consumption (kW)															
			100%		90%		80%		70%		60%		50%		40%		30%	
			TC (kW)	PI (kW)	TC (kW)	PI (kW)	TC (kW)	PI (kW)	TC (kW)	PI (kW)	TC (kW)	PI (kW)	TC (kW)	PI (kW)	TC (kW)	PI (kW)	TC (kW)	PI (kW)
40 °C	151.2	151.2	59.2	136.1	47.1	121.0	36.9	105.9	28.6	90.7	21.7	75.6	16.2	60.5	11.6	45.4	7.79	
39 °C	153.7	153.7	58.3	138.3	46.4	122.9	36.4	107.6	28.2	92.2	21.4	76.8	15.9	61.5	11.4	46.1	7.67	
37 °C	158.2	158.2	56.6	142.4	45.0	126.6	35.3	110.8	27.3	94.9	20.8	79.1	15.4	63.3	11.1	47.5	7.44	
35 °C	162.5	162.5	54.8	146.2	43.5	130.0	34.2	113.7	26.4	97.5	20.1	81.2	14.9	65.0	10.7	48.7	7.20	
33 °C	162.5	162.5	50.3	146.3	40.1	130.0	31.5	113.8	24.5	97.5	18.7	81.3	13.9	65.0	10.0	48.8	6.75	
31 °C	162.5	162.5	46.3	146.3	37.0	130.0	29.2	113.8	22.7	97.5	17.4	81.3	13.0	65.0	9.39	48.8	6.33	
30 °C	162.5	162.5	44.5	146.3	35.6	130.0	28.1	113.8	21.9	97.5	16.8	81.3	12.6	65.0	9.10	48.8	6.13	
29 °C	162.5	162.5	42.8	146.3	34.3	130.0	27.1	113.8	21.2	97.5	16.3	81.3	12.2	65.0	8.81	48.8	5.95	
27 °C	162.5	162.5	39.7	146.3	31.9	130.0	25.3	113.8	19.8	97.5	15.2	81.3	11.4	65.0	8.28	48.8	5.59	
25 °C	162.5	162.5	36.9	146.3	29.7	130.0	23.6	113.8	18.5	97.5	14.2	81.3	10.7	65.0	7.78	48.8	5.26	
23 °C	162.5	162.5	35.1	146.3	28.3	130.0	22.5	113.8	17.7	97.5	13.6	81.3	10.3	65.0	7.48	48.8	5.06	
21 °C	162.5	162.5	34.2	146.3	27.6	130.0	22.0	113.8	17.3	97.5	13.4	81.3	10.1	65.0	7.35	48.8	4.98	
20 °C	162.5	162.5	33.9	146.3	27.3	130.0	21.8	113.8	17.1	97.5	13.3	81.3	10.0	65.0	7.30	48.8	4.94	
19 °C	162.5	162.5	33.5	146.3	27.0	130.0	21.6	113.8	17.0	97.5	13.2	81.3	9.96	65.0	7.25	48.8	4.91	
17 °C	162.5	162.5	32.9	146.3	26.6	130.0	21.2	113.8	16.7	97.5	13.0	81.3	9.83	65.0	7.16	48.8	4.85	
15 °C	162.5	162.5	32.3	146.3	26.1	130.0	20.9	113.8	16.5	97.5	12.8	81.3	9.71	65.0	7.08	48.8	4.80	

TC : Total Capacity PI : Power Input
 Indoor air temperature conditions : 27.0°C dry-bulb / 19.0°C wet bulb

Heating		Outdoor Unit 100% Capacity (kW)	Compressor + Outdoor Fan Power consumption (kW)															
			100%		90%		80%		70%		60%		50%		40%		30%	
			TC (kW)	PI (kW)	TC (kW)	PI (kW)	TC (kW)	PI (kW)	TC (kW)	PI (kW)	TC (kW)	PI (kW)	TC (kW)	PI (kW)	TC (kW)	PI (kW)	TC (kW)	PI (kW)
Dry-Bulb (°C)	Wet-Bulb (°C)	Heating Capacity (kW)	Capacity		Capacity		Capacity		Capacity		Capacity		Capacity		Capacity		Capacity	
15.0	13.7	177.0	177.0	40.4	159.3	34.0	141.6	28.5	123.9	23.7	106.2	19.5	88.5	15.7	70.8	12.3	53.1	9.00
13.0	11.8	177.0	177.0	42.1	159.3	35.3	141.6	29.5	123.9	24.5	106.2	20.1	88.5	16.2	70.8	12.6	53.1	9.24
11.0	9.8	177.0	177.0	44.2	159.3	36.9	141.6	30.7	123.9	25.3	106.2	20.7	88.5	16.6	70.8	13.0	53.1	9.50
9.0	7.9	177.0	177.0	46.3	159.3	38.5	141.6	31.9	123.9	26.3	106.2	21.4	88.5	17.1	70.8	13.3	53.1	9.76
7.0	6.0	177.0	177.0	48.7	159.3	40.4	141.6	33.3	123.9	27.3	106.2	22.1	88.5	17.7	70.8	13.7	53.1	10.0
5.0	4.1	170.7	170.7	48.3	153.6	40.0	136.5	33.0	119.5	27.1	102.4	22.0	85.3	17.5	68.3	13.6	51.2	9.96
3.0	2.2	164.3	164.3	48.0	147.9	39.7	131.5	32.8	115.0	26.9	98.6	21.8	82.2	17.4	65.7	13.5	49.3	9.88
0.0	-0.7	154.6	154.6	47.4	139.2	39.3	123.7	32.4	108.3	26.5	92.8	21.5	77.3	17.2	61.9	13.3	46.4	9.76
-3.0	-3.7	144.6	144.6	46.8	130.2	38.8	115.7	32.0	101.2	26.2	86.8	21.3	72.3	17.0	57.9	13.2	43.4	9.64
-5.0	-5.6	138.3	138.3	46.4	124.5	38.5	110.6	31.7	96.8	26.0	83.0	21.1	69.2	16.9	55.3	13.1	41.5	9.57
-7.0	-7.6	131.6	131.6	46.0	118.5	38.2	105.3	31.5	92.1	25.8	79.0	20.9	65.8	16.7	52.7	13.0	39.5	9.49
-10	-10.5	122.0	122.0	45.5	109.8	37.7	97.6	31.1	85.4	25.5	73.2	20.7	61.0	16.5	48.8	12.8	36.6	9.37
-14.5	-15.0	106.9	106.9	44.6	96.3	37.0	85.6	30.5	74.9	25.0	64.2	20.3	53.5	16.2	42.8	12.6	32.1	9.19

TC : Total Capacity PI : Power Input
 Indoor air temperature conditions : 20.0°C dry-bulb



MMY-AP6016HT8P-E (60HP, 168kW system)

Cooling

Outdoor Unit (°C)	Outdoor Unit 100% Capacity (kW)	Compressor + Outdoor Fan Power consumption (kW)															
		100%		90%		80%		70%		60%		50%		40%		30%	
		TC (kW)	PI (kW)	TC (kW)	PI (kW)	TC (kW)	PI (kW)	TC (kW)	PI (kW)	TC (kW)	PI (kW)	TC (kW)	PI (kW)	TC (kW)	PI (kW)	TC (kW)	PI (kW)
40 °C	156.3	156.3	65.6	140.7	51.7	125.1	40.2	109.4	30.7	93.8	22.9	78.2	16.8	62.5	11.8	46.9	7.89
39 °C	158.9	158.9	64.6	143.0	50.9	127.1	39.6	111.2	30.2	95.3	22.6	79.4	16.5	63.5	11.6	47.7	7.78
37 °C	163.6	163.6	62.7	147.2	49.4	130.9	38.4	114.5	29.3	98.2	21.9	81.8	16.0	65.4	11.3	49.1	7.54
35 °C	168.0	168.0	60.7	151.2	47.8	134.4	37.2	117.6	28.4	100.8	21.2	84.0	15.5	67.2	10.9	50.4	7.30
33 °C	168.0	168.0	55.6	151.2	43.9	134.4	34.2	117.6	26.2	100.8	19.7	84.0	14.4	67.2	10.2	50.4	6.84
31 °C	168.0	168.0	51.1	151.2	40.5	134.4	31.6	117.6	24.3	100.8	18.3	84.0	13.4	67.2	9.56	50.4	6.42
30 °C	168.0	168.0	49.1	151.2	38.9	134.4	30.4	117.6	23.4	100.8	17.7	84.0	13.0	67.2	9.25	50.4	6.23
29 °C	168.0	168.0	47.2	151.2	37.5	134.4	29.3	117.6	22.6	100.8	17.0	84.0	12.6	67.2	8.96	50.4	6.04
27 °C	168.0	168.0	43.7	151.2	34.8	134.4	27.3	117.6	21.0	100.8	15.9	84.0	11.8	67.2	8.41	50.4	5.68
25 °C	168.0	168.0	40.6	151.2	32.3	134.4	25.4	117.6	19.6	100.8	14.9	84.0	11.0	67.2	7.90	50.4	5.35
23 °C	168.0	168.0	38.6	151.2	30.8	134.4	24.2	117.6	18.7	100.8	14.2	84.0	10.6	67.2	7.59	50.4	5.14
21 °C	168.0	168.0	37.6	151.2	30.0	134.4	23.6	117.6	18.3	100.8	14.0	84.0	10.4	67.2	7.46	50.4	5.06
20 °C	168.0	168.0	37.1	151.2	29.7	134.4	23.4	117.6	18.2	100.8	13.8	84.0	10.3	67.2	7.41	50.4	5.03
19 °C	168.0	168.0	36.7	151.2	29.4	134.4	23.2	117.6	18.0	100.8	13.7	84.0	10.2	67.2	7.36	50.4	5.00
17 °C	168.0	168.0	36.0	151.2	28.8	134.4	22.7	117.6	17.7	100.8	13.5	84.0	10.1	67.2	7.26	50.4	4.94
15 °C	168.0	168.0	35.4	151.2	28.3	134.4	22.4	117.6	17.4	100.8	13.3	84.0	9.95	67.2	7.18	50.4	4.89

TC : Total Capacity PI : Power Input
Indoor air temperature conditions : 27.0°C dry-bulb / 19.0°C wet bulb

Heating

Outdoor Unit		Outdoor Unit 100% Heating Capacity (kW)	Compressor + Outdoor Fan Power consumption (kW)															
Dry-Bulb (°C)	Wet-Bulb (°C)		100% Capacity		90% Capacity		80% Capacity		70% Capacity		60% Capacity		50% Capacity		40% Capacity		30% Capacity	
			TC (kW)	PI (kW)	TC (kW)	PI (kW)	TC (kW)	PI (kW)	TC (kW)	PI (kW)	TC (kW)	PI (kW)	TC (kW)	PI (kW)	TC (kW)	PI (kW)	TC (kW)	PI (kW)
15.0	13.7	178.0	178.0	41.8	160.2	35.2	142.4	29.5	124.6	24.5	106.8	20.2	89.0	16.4	71.2	12.8	53.4	9.36
13.0	11.8	178.0	178.0	43.7	160.2	36.6	142.4	30.5	124.6	25.3	106.8	20.8	89.0	16.8	71.2	13.1	53.4	9.61
11.0	9.8	178.0	178.0	45.8	160.2	38.2	142.4	31.8	124.6	26.3	106.8	21.5	89.0	17.3	71.2	13.5	53.4	9.88
9.0	7.9	178.0	178.0	48.0	160.2	39.9	142.4	33.0	124.6	27.2	106.8	22.2	89.0	17.8	71.2	13.9	53.4	10.2
7.0	6.0	178.0	178.0	50.5	160.2	41.8	142.4	34.4	124.6	28.2	106.8	23.0	89.0	18.4	71.2	14.3	53.4	10.4
5.0	4.1	171.6	171.6	50.1	154.5	41.5	137.3	34.2	120.1	28.0	103.0	22.8	85.8	18.2	68.6	14.2	51.5	10.4
3.0	2.2	165.2	165.2	49.7	148.7	41.2	132.2	33.9	115.7	27.8	99.1	22.6	82.6	18.1	66.1	14.1	49.6	10.3
0.0	-0.7	155.5	155.5	49.1	140.0	40.7	124.4	33.5	108.9	27.5	93.3	22.3	77.8	17.9	62.2	13.9	46.7	10.2
-3.0	-3.7	145.5	145.5	48.5	130.9	40.2	116.4	33.1	101.8	27.1	87.3	22.1	72.7	17.7	58.2	13.7	43.6	10.0
-5.0	-5.6	139.1	139.1	48.2	125.2	39.8	111.3	32.8	97.4	26.9	83.4	21.9	69.5	17.5	55.6	13.6	41.7	9.96
-7.0	-7.6	132.4	132.4	47.7	119.1	39.5	105.9	32.6	92.7	26.7	79.4	21.7	66.2	17.4	52.9	13.5	39.7	9.88
-10	-10.5	122.6	122.6	47.2	110.4	39.0	98.1	32.2	85.9	26.4	73.6	21.4	61.3	17.2	49.1	13.3	36.8	9.76
-14.5	-15.0	107.5	107.5	46.3	96.8	38.3	86.0	31.5	75.3	25.9	64.5	21.0	53.8	16.8	43.0	13.1	32.3	9.57

TC : Total Capacity PI : Power Input
Indoor air temperature conditions : 20.0°C dry-bulb



MMY-AP2026HT8P-E (20HP, 56kW system)

Cooling		Compressor + Outdoor Fan Power consumption (kW)																	
		Outdoor Unit (°C)	Outdoor Unit 100% Capacity (kW)	100%		90%		80%		70%		60%		50%		40%		30%	
				TC (kW)	PI (kW)	TC (kW)	PI (kW)	TC (kW)	PI (kW)	TC (kW)	PI (kW)	TC (kW)	PI (kW)	TC (kW)	PI (kW)	TC (kW)	PI (kW)	TC (kW)	PI (kW)
40 °C	52.1	52.1	16.6	46.9	13.5	41.7	10.8	36.5	8.47	31.3	6.48	26.1	4.87	20.8	3.63	15.6	2.77		
39 °C	53.0	53.0	16.4	47.7	13.3	42.4	10.7	37.1	8.34	31.8	6.39	26.5	4.80	21.2	3.58	15.9	2.73		
37 °C	54.5	54.5	15.9	49.1	12.9	43.6	10.3	38.2	8.09	32.7	6.19	27.3	4.65	21.8	3.47	16.4	2.65		
35 °C	56.0	56.0	15.4	50.4	12.5	44.8	10.0	39.2	7.84	33.6	6.00	28.0	4.50	22.4	3.36	16.8	2.57		
33 °C	56.0	56.0	14.2	50.4	11.6	44.8	9.27	39.2	7.26	33.6	5.58	28.0	4.21	22.4	3.16	16.8	2.44		
31 °C	56.0	56.0	13.1	50.4	10.7	44.8	8.60	39.2	6.75	33.6	5.20	28.0	3.94	22.4	2.98	16.8	2.32		
30 °C	56.0	56.0	12.7	50.4	10.3	44.8	8.29	39.2	6.52	33.6	5.03	28.0	3.82	22.4	2.90	16.8	2.27		
29 °C	56.0	56.0	12.2	50.4	10.0	44.8	8.00	39.2	6.30	33.6	4.86	28.0	3.70	22.4	2.82	16.8	2.21		
27 °C	56.0	56.0	11.4	50.4	9.29	44.8	7.46	39.2	5.88	33.6	4.55	28.0	3.48	22.4	2.66	16.8	2.11		
25 °C	56.0	56.0	10.6	50.4	8.67	44.8	6.97	39.2	5.50	33.6	4.27	28.0	3.27	22.4	2.52	16.8	2.00		
23 °C	56.0	56.0	10.1	50.4	8.27	44.8	6.66	39.2	5.26	33.6	4.09	28.0	3.15	22.4	2.43	16.8	1.95		
21 °C	56.0	56.0	9.88	50.4	8.09	44.8	6.52	39.2	5.16	33.6	4.02	28.0	3.10	22.4	2.40	16.8	1.93		
20 °C	56.0	56.0	9.78	50.4	8.01	44.8	6.45	39.2	5.11	33.6	3.98	28.0	3.08	22.4	2.39	16.8	1.93		
19 °C	56.0	56.0	9.69	50.4	7.94	44.8	6.39	39.2	5.07	33.6	3.95	28.0	3.06	22.4	2.38	16.8	1.92		
17 °C	56.0	56.0	9.52	50.4	7.80	44.8	6.29	39.2	4.99	33.6	3.90	28.0	3.02	22.4	2.36	16.8	1.91		
15 °C	56.0	56.0	9.38	50.4	7.69	44.8	6.20	39.2	4.92	33.6	3.85	28.0	2.99	22.4	2.34	16.8	1.90		

TC : Total Capacity PI : Power Input
 Indoor air temperature conditions : 27.0°C dry-bulb / 19.0°C wet bulb

Heating		Compressor + Outdoor Fan Power consumption (kW)																		
		Outdoor Unit Dry-Bulb (°C)	Outdoor Unit Wet-Bulb (°C)	Outdoor Unit Heating Capacity (kW)	100%		90%		80%		70%		60%		50%		40%		30%	
					TC (kW)	PI (kW)	TC (kW)	PI (kW)	TC (kW)	PI (kW)	TC (kW)	PI (kW)	TC (kW)	PI (kW)	TC (kW)	PI (kW)	TC (kW)	PI (kW)	TC (kW)	PI (kW)
15.0	13.7	63.0	63.0	12.0	56.7	9.91	50.4	8.25	44.1	6.89	37.8	5.75	31.5	4.75	25.2	3.81	18.9	2.84		
13.0	11.8	63.0	63.0	12.5	56.7	10.3	50.4	8.55	44.1	7.10	37.8	5.90	31.5	4.87	25.2	3.90	18.9	2.91		
11.0	9.8	63.0	63.0	13.2	56.7	10.8	50.4	8.90	44.1	7.35	37.8	6.08	31.5	4.99	25.2	4.00	18.9	2.99		
9.0	7.9	63.0	63.0	14.0	56.7	11.4	50.4	9.28	44.1	7.61	37.8	6.26	31.5	5.12	25.2	4.09	18.9	3.07		
7.0	6.0	63.0	63.0	14.8	56.7	12.0	50.4	9.70	44.1	7.90	37.8	6.46	31.5	5.27	25.2	4.20	18.9	3.15		
5.0	4.1	61.0	61.0	14.7	54.9	11.9	48.8	9.64	42.7	7.85	36.6	6.42	30.5	5.24	24.4	4.18	18.3	3.13		
3.0	2.2	58.9	58.9	14.6	53.1	11.8	47.2	9.58	41.3	7.81	35.4	6.39	29.5	5.21	23.6	4.15	17.7	3.11		
0.0	-0.7	55.9	55.9	14.5	50.3	11.7	44.7	9.50	39.1	7.74	33.5	6.33	27.9	5.16	22.3	4.12	16.8	3.09		
-3.0	-3.7	52.7	52.7	14.4	47.4	11.6	42.1	9.41	36.9	7.67	31.6	6.27	26.3	5.11	21.1	4.08	15.8	3.06		
-5.0	-5.6	50.6	50.6	14.3	45.6	11.5	40.5	9.36	35.4	7.62	30.4	6.24	25.3	5.08	20.3	4.05	15.2	3.04		
-7.0	-7.6	48.5	48.5	14.2	43.6	11.5	38.8	9.30	33.9	7.58	29.1	6.20	24.2	5.05	19.4	4.03	14.5	3.02		
-10	-10.5	45.4	45.4	14.1	40.9	11.4	36.3	9.21	31.8	7.51	27.2	6.14	22.7	5.00	18.2	3.99	13.6	2.99		
-14.5	-15.0	40.6	40.6	13.9	36.5	11.2	32.5	9.08	28.4	7.40	24.4	6.05	20.3	4.93	16.2	3.94	12.2	2.95		

TC : Total Capacity PI : Power Input
 Indoor air temperature conditions : 20.0°C dry-bulb



MMY-AP2226HT8P-E (22HP, 61.5kW system)

Outdoor Unit (°C)		Outdoor Unit 100% Capacity (kW)	Compressor + Outdoor Fan Power consumption (kW)															
			100%		90%		80%		70%		60%		50%		40%		30%	
			TC (kW)	PI (kW)	TC (kW)	PI (kW)	TC (kW)	PI (kW)	TC (kW)	PI (kW)	TC (kW)	PI (kW)	TC (kW)	PI (kW)	TC (kW)	PI (kW)	TC (kW)	PI (kW)
40 °C		57.2	19.1	51.5	15.4	45.8	12.3	40.1	9.58	34.3	7.35	28.6	5.52	22.9	4.06	17.2	2.92	
39 °C		58.2	18.8	52.3	15.2	46.5	12.1	40.7	9.44	34.9	7.24	29.1	5.44	23.3	4.00	17.4	2.88	
37 °C		59.9	18.3	53.9	14.7	47.9	11.7	41.9	9.16	35.9	7.02	29.9	5.28	24.0	3.88	18.0	2.79	
35 °C		61.5	17.7	55.4	14.3	49.2	11.3	43.0	8.87	36.9	6.80	30.7	5.11	24.6	3.76	18.4	2.71	
33 °C		61.5	16.3	55.4	13.2	49.2	10.5	43.1	8.22	36.9	6.33	30.8	4.77	24.6	3.53	18.5	2.55	
31 °C		61.5	15.1	55.4	12.2	49.2	9.73	43.1	7.64	36.9	5.90	30.8	4.47	24.6	3.31	18.5	2.42	
30 °C		61.5	14.5	55.4	11.7	49.2	9.38	43.1	7.38	36.9	5.70	30.8	4.32	24.6	3.22	18.5	2.35	
29 °C		61.5	14.0	55.4	11.3	49.2	9.05	43.1	7.13	36.9	5.52	30.8	4.19	24.6	3.12	18.5	2.29	
27 °C		61.5	13.0	55.4	10.5	49.2	8.44	43.1	6.66	36.9	5.16	30.8	3.93	24.6	2.94	18.5	2.16	
25 °C		61.5	12.1	55.4	9.83	49.2	7.88	43.1	6.23	36.9	4.84	30.8	3.70	24.6	2.77	18.5	2.05	
23 °C		61.5	11.5	55.4	9.38	49.2	7.53	43.1	5.96	36.9	4.64	30.8	3.55	24.6	2.67	18.5	1.98	
21 °C		61.5	11.2	55.4	9.17	49.2	7.37	43.1	5.84	36.9	4.56	30.8	3.50	24.6	2.64	18.5	1.96	
20 °C		61.5	11.1	55.4	9.07	49.2	7.30	43.1	5.79	36.9	4.52	30.8	3.47	24.6	2.62	18.5	1.95	
19 °C		61.5	11.0	55.4	8.99	49.2	7.23	43.1	5.74	36.9	4.48	30.8	3.45	24.6	2.60	18.5	1.94	
17 °C		61.5	10.8	55.4	8.83	49.2	7.12	43.1	5.65	36.9	4.42	30.8	3.40	24.6	2.58	18.5	1.92	
15 °C		61.5	10.7	55.4	8.70	49.2	7.02	43.1	5.58	36.9	4.37	30.8	3.37	24.6	2.55	18.5	1.91	

TC : Total Capacity PI : Power Input
Indoor air temperature conditions : 27.0°C dry-bulb / 19.0°C wet bulb

Outdoor Unit Dry-Bulb (°C) Wet-Bulb (°C)			Outdoor Unit 100% Heating Capacity (kW)	Compressor + Outdoor Fan Power consumption (kW)															
				100% Capacity		90% Capacity		80% Capacity		70% Capacity		60% Capacity		50% Capacity		40% Capacity		30% Capacity	
				TC (kW)	PI (kW)	TC (kW)	PI (kW)	TC (kW)	PI (kW)	TC (kW)	PI (kW)	TC (kW)	PI (kW)	TC (kW)	PI (kW)	TC (kW)	PI (kW)	TC (kW)	PI (kW)
15.0	13.7	69.0	69.0	13.9	62.1	11.6	55.2	9.66	48.3	8.05	41.4	6.68	34.5	5.46	27.6	4.30	20.7	3.12	
13.0	11.8	69.0	69.0	14.6	62.1	12.1	55.2	10.0	48.3	8.31	41.4	6.87	34.5	5.60	27.6	4.41	20.7	3.21	
11.0	9.8	69.0	69.0	15.3	62.1	12.6	55.2	10.4	48.3	8.60	41.4	7.08	34.5	5.76	27.6	4.53	20.7	3.31	
9.0	7.9	69.0	69.0	16.1	62.1	13.2	55.2	10.8	48.3	8.91	41.4	7.30	34.5	5.92	27.6	4.65	20.7	3.40	
7.0	6.0	69.0	69.0	17.1	62.1	13.9	55.2	11.3	48.3	9.25	41.4	7.54	34.5	6.09	27.6	4.78	20.7	3.50	
5.0	4.1	66.6	66.6	16.9	60.0	13.8	53.3	11.2	46.6	9.19	40.0	7.49	33.3	6.05	26.7	4.75	20.0	3.48	
3.0	2.2	64.3	64.3	16.8	57.9	13.7	51.4	11.2	45.0	9.12	38.6	7.44	32.1	6.01	25.7	4.72	19.3	3.46	
0.0	-0.7	60.7	60.7	16.6	54.6	13.6	48.6	11.1	42.5	9.03	36.4	7.36	30.3	5.95	24.3	4.67	18.2	3.42	
-3.0	-3.7	57.0	57.0	16.5	51.3	13.4	45.6	10.9	39.9	8.93	34.2	7.28	28.5	5.88	22.8	4.62	17.1	3.38	
-5.0	-5.6	54.6	54.6	16.4	49.2	13.3	43.7	10.9	38.2	8.87	32.8	7.23	27.3	5.84	21.8	4.59	16.4	3.36	
-7.0	-7.6	52.1	52.1	16.2	46.9	13.2	41.7	10.8	36.5	8.80	31.3	7.18	26.1	5.80	20.9	4.55	15.6	3.33	
-10	-10.5	48.5	48.5	16.1	43.7	13.1	38.8	10.7	34.0	8.70	29.1	7.10	24.3	5.73	19.4	4.50	14.6	3.30	
-14.5	-15.0	43.0	43.0	15.8	38.7	12.8	34.4	10.5	30.1	8.55	25.8	6.98	21.5	5.64	17.2	4.43	12.9	3.24	

TC : Total Capacity PI : Power Input
Indoor air temperature conditions : 20.0°C dry-bulb



MMY-AP3626HT8P-E (36HP, 100.5kW system)

Outdoor Unit (°C)		Outdoor Unit 100% Capacity (kW)	Compressor + Outdoor Fan Power consumption (kW)															
			100%		90%		80%		70%		60%		50%		40%		30%	
			TC (kW)	PI (kW)	TC (kW)	PI (kW)	TC (kW)	PI (kW)	TC (kW)	PI (kW)	TC (kW)	PI (kW)	TC (kW)	PI (kW)	TC (kW)	PI (kW)	TC (kW)	PI (kW)
40 °C	93.5	93.5	32.4	84.2	26.0	74.8	20.5	65.5	16.0	56.1	12.3	46.8	9.26	37.4	6.73	28.1	4.61	
39 °C	95.0	95.0	31.9	85.5	25.6	76.0	20.2	66.5	15.8	57.0	12.1	47.5	9.12	38.0	6.63	28.5	4.54	
37 °C	97.9	97.9	31.0	88.1	24.8	78.3	19.6	68.5	15.3	58.7	11.8	48.9	8.85	39.1	6.43	29.4	4.41	
35 °C	100.5	100.5	30.0	90.4	24.0	80.4	19.0	70.3	14.8	60.3	11.4	50.2	8.57	40.2	6.23	30.1	4.27	
33 °C	100.5	100.5	27.6	90.5	22.1	80.4	17.6	70.4	13.8	60.3	10.6	50.3	8.00	40.2	5.83	30.2	4.00	
31 °C	100.5	100.5	25.4	90.5	20.5	80.4	16.3	70.4	12.8	60.3	9.90	50.3	7.48	40.2	5.47	30.2	3.76	
30 °C	100.5	100.5	24.5	90.5	19.7	80.4	15.7	70.4	12.4	60.3	9.57	50.3	7.24	40.2	5.30	30.2	3.65	
29 °C	100.5	100.5	23.6	90.5	19.0	80.4	15.2	70.4	11.9	60.3	9.25	50.3	7.01	40.2	5.14	30.2	3.54	
27 °C	100.5	100.5	21.9	90.5	17.7	80.4	14.1	70.4	11.2	60.3	8.66	50.3	6.58	40.2	4.83	30.2	3.33	
25 °C	100.5	100.5	20.3	90.5	16.5	80.4	13.2	70.4	10.4	60.3	8.12	50.3	6.18	40.2	4.55	30.2	3.14	
23 °C	100.5	100.5	19.4	90.5	15.7	80.4	12.6	70.4	10.0	60.3	7.79	50.3	5.94	40.2	4.37	30.2	3.02	
21 °C	100.5	100.5	18.9	90.5	15.4	80.4	12.3	70.4	9.79	60.3	7.65	50.3	5.84	40.2	4.30	30.2	2.98	
20 °C	100.5	100.5	18.7	90.5	15.2	80.4	12.2	70.4	9.70	60.3	7.58	50.3	5.79	40.2	4.27	30.2	2.96	
19 °C	100.5	100.5	18.5	90.5	15.1	80.4	12.1	70.4	9.62	60.3	7.52	50.3	5.75	40.2	4.25	30.2	2.94	
17 °C	100.5	100.5	18.2	90.5	14.8	80.4	11.9	70.4	9.48	60.3	7.42	50.3	5.68	40.2	4.19	30.2	2.90	
15 °C	100.5	100.5	17.9	90.5	14.6	80.4	11.7	70.4	9.35	60.3	7.33	50.3	5.62	40.2	4.15	30.2	2.88	

TC : Total Capacity PI : Power Input
Indoor air temperature conditions : 27.0°C dry-bulb / 19.0°C wet bulb

Outdoor Unit Dry-Bulb (°C) Wet-Bulb (°C)			Outdoor Unit 100% Heating Capacity (kW)	Compressor + Outdoor Fan Power consumption (kW)															
				100% Capacity		90% Capacity		80% Capacity		70% Capacity		60% Capacity		50% Capacity		40% Capacity		30% Capacity	
				TC (kW)	PI (kW)	TC (kW)	PI (kW)	TC (kW)	PI (kW)	TC (kW)	PI (kW)	TC (kW)	PI (kW)	TC (kW)	PI (kW)	TC (kW)	PI (kW)	TC (kW)	PI (kW)
15.0	13.7	112.5	112.5	23.7	101.3	19.9	90.0	16.6	78.8	13.8	67.5	11.4	56.3	9.24	45.0	7.18	33.8	5.11	
13.0	11.8	112.5	112.5	24.8	101.3	20.7	90.0	17.2	78.8	14.3	67.5	11.7	56.3	9.50	45.0	7.38	33.8	5.26	
11.0	9.8	112.5	112.5	26.1	101.3	21.6	90.0	17.9	78.8	14.8	67.5	12.1	56.3	9.78	45.0	7.60	33.8	5.43	
9.0	7.9	112.5	112.5	27.4	101.3	22.6	90.0	18.6	78.8	15.3	67.5	12.5	56.3	10.1	45.0	7.82	33.8	5.60	
7.0	6.0	112.5	112.5	28.9	101.3	23.7	90.0	19.4	78.8	15.9	67.5	12.9	56.3	10.4	45.0	8.05	33.8	5.78	
5.0	4.1	108.5	108.5	28.7	97.6	23.6	86.8	19.3	75.9	15.8	65.1	12.8	54.2	10.3	43.4	7.99	32.5	5.74	
3.0	2.2	104.4	104.4	28.5	94.0	23.4	83.6	19.1	73.1	15.7	62.7	12.7	52.2	10.2	41.8	7.93	31.3	5.70	
0.0	-0.7	98.3	98.3	28.2	88.5	23.1	78.6	18.9	68.8	15.5	59.0	12.6	49.1	10.1	39.3	7.84	29.5	5.63	
-3.0	-3.7	91.9	91.9	27.8	82.7	22.8	73.5	18.7	64.4	15.3	55.2	12.4	46.0	10.0	36.8	7.74	27.6	5.56	
-5.0	-5.6	87.9	87.9	27.6	79.1	22.6	70.3	18.5	61.5	15.2	52.7	12.3	44.0	9.90	35.2	7.68	26.4	5.52	
-7.0	-7.6	83.7	83.7	27.4	75.3	22.4	66.9	18.4	58.6	15.0	50.2	12.2	41.8	9.81	33.5	7.61	25.1	5.47	
-10	-10.5	77.5	77.5	27.0	69.8	22.2	62.0	18.2	54.3	14.8	46.5	12.1	38.8	9.69	31.0	7.52	23.3	5.40	
-14.5	-15.0	68.0	68.0	26.5	61.2	21.7	54.4	17.8	47.6	14.6	40.8	11.9	34.0	9.51	27.2	7.38	20.4	5.30	

TC : Total Capacity PI : Power Input
Indoor air temperature conditions : 20.0°C dry-bulb



MMY-AP3826HT8P-E (38HP, 107kW system)

Cooling		Compressor + Outdoor Fan Power consumption (kW)																	
		Outdoor Unit 100% Capacity (kW)		100%		90%		80%		70%		60%		50%		40%		30%	
		TC (kW)	PI (kW)	TC (kW)	PI (kW)	TC (kW)	PI (kW)	TC (kW)	PI (kW)	TC (kW)	PI (kW)	TC (kW)	PI (kW)	TC (kW)	PI (kW)	TC (kW)	PI (kW)	TC (kW)	PI (kW)
40 °C	99.6	99.6	34.9	89.6	27.8	79.7	21.9	69.7	17.1	59.7	13.2	49.8	10.0	39.8	7.31	29.9	5.03		
39 °C	101.2	101.2	34.4	91.1	27.4	80.9	21.6	70.8	16.8	60.7	13.0	50.6	9.82	40.5	7.20	30.4	4.95		
37 °C	104.2	104.2	33.3	93.8	26.5	83.4	20.9	72.9	16.3	62.5	12.6	52.1	9.52	41.7	6.98	31.3	4.80		
35 °C	107.0	107.0	32.3	96.3	25.7	85.6	20.3	74.9	15.8	64.2	12.2	53.5	9.22	42.8	6.76	32.1	4.65		
33 °C	107.0	107.0	29.6	96.3	23.7	85.6	18.7	74.9	14.7	64.2	11.3	53.5	8.62	42.8	6.34	32.1	4.36		
31 °C	107.0	107.0	27.3	96.3	21.9	85.6	17.4	74.9	13.6	64.2	10.6	53.5	8.07	42.8	5.95	32.1	4.10		
30 °C	107.0	107.0	26.2	96.3	21.1	85.6	16.7	74.9	13.2	64.2	10.2	53.5	7.81	42.8	5.77	32.1	3.97		
29 °C	107.0	107.0	25.3	96.3	20.3	85.6	16.1	74.9	12.7	64.2	9.91	53.5	7.57	42.8	5.59	32.1	3.85		
27 °C	107.0	107.0	23.4	96.3	18.9	85.6	15.1	74.9	11.9	64.2	9.29	53.5	7.11	42.8	5.26	32.1	3.63		
25 °C	107.0	107.0	21.8	96.3	17.6	85.6	14.1	74.9	11.1	64.2	8.71	53.5	6.68	42.8	4.95	32.1	3.41		
23 °C	107.0	107.0	20.7	96.3	16.8	85.6	13.4	74.9	10.7	64.2	8.36	53.5	6.42	42.8	4.76	32.1	3.28		
21 °C	107.0	107.0	20.2	96.3	16.4	85.6	13.1	74.9	10.5	64.2	8.21	53.5	6.32	42.8	4.69	32.1	3.23		
20 °C	107.0	107.0	20.0	96.3	16.2	85.6	13.0	74.9	10.4	64.2	8.14	53.5	6.27	42.8	4.66	32.1	3.21		
19 °C	107.0	107.0	19.8	96.3	16.0	85.6	12.9	74.9	10.3	64.2	8.08	53.5	6.23	42.8	4.62	32.1	3.19		
17 °C	107.0	107.0	19.4	96.3	15.8	85.6	12.7	74.9	10.1	64.2	7.97	53.5	6.15	42.8	4.57	32.1	3.15		
15 °C	107.0	107.0	19.1	96.3	15.5	85.6	12.5	74.9	10.0	64.2	7.88	53.5	6.08	42.8	4.52	32.1	3.12		

TC : Total Capacity PI : Power Input
 Indoor air temperature conditions : 27.0°C dry-bulb / 19.0°C wet bulb

Heating		Compressor + Outdoor Fan Power consumption (kW)																	
		Outdoor Unit 100% Heating Capacity (kW)		100% Capacity		90% Capacity		80% Capacity		70% Capacity		60% Capacity		50% Capacity		40% Capacity		30% Capacity	
		Dry-Bulb (°C)	Wet-Bulb (°C)	TC (kW)	PI (kW)	TC (kW)	PI (kW)	TC (kW)	PI (kW)	TC (kW)	PI (kW)	TC (kW)	PI (kW)	TC (kW)	PI (kW)	TC (kW)	PI (kW)	TC (kW)	PI (kW)
15.0	13.7	120.0	120.0	24.9	108.0	20.7	96.0	17.3	84.0	14.3	72.0	11.9	60.0	9.69	48.0	7.68	36.0	5.71	
13.0	11.8	120.0	120.0	26.1	108.0	21.6	96.0	17.9	84.0	14.8	72.0	12.2	60.0	9.94	48.0	7.87	36.0	5.85	
11.0	9.8	120.0	120.0	27.4	108.0	22.6	96.0	18.6	84.0	15.3	72.0	12.6	60.0	10.2	48.0	8.08	36.0	6.01	
9.0	7.9	120.0	120.0	28.9	108.0	23.7	96.0	19.4	84.0	15.9	72.0	13.0	60.0	10.5	48.0	8.29	36.0	6.17	
7.0	6.0	120.0	120.0	30.5	108.0	24.9	96.0	20.3	84.0	16.5	72.0	13.4	60.0	10.8	48.0	8.51	36.0	6.34	
5.0	4.1	115.9	115.9	30.3	104.3	24.7	92.7	20.1	81.1	16.4	69.5	13.3	57.9	10.7	46.3	8.45	34.8	6.29	
3.0	2.2	111.7	111.7	30.1	100.6	24.5	89.4	20.0	78.2	16.3	67.0	13.2	55.9	10.7	44.7	8.39	33.5	6.25	
0.0	-0.7	105.4	105.4	29.8	94.9	24.3	84.3	19.8	73.8	16.1	63.3	13.1	52.7	10.6	42.2	8.30	31.6	6.18	
-3.0	-3.7	98.9	98.9	29.4	89.0	24.0	79.1	19.6	69.2	15.9	59.3	12.9	49.4	10.4	39.6	8.21	29.7	6.11	
-5.0	-5.6	94.8	94.8	29.2	85.3	23.8	75.8	19.4	66.3	15.8	56.9	12.9	47.4	10.4	37.9	8.15	28.4	6.07	
-7.0	-7.6	90.4	90.4	29.0	81.4	23.6	72.3	19.3	63.3	15.7	54.2	12.8	45.2	10.3	36.2	8.09	27.1	6.03	
-10	-10.5	84.1	84.1	28.7	75.7	23.4	67.3	19.1	58.9	15.5	50.5	12.6	42.1	10.2	33.6	8.00	25.2	5.96	
-14.5	-15.0	74.3	74.3	28.2	66.9	23.0	59.5	18.7	52.0	15.3	44.6	12.4	37.2	10.0	29.7	7.86	22.3	5.86	

TC : Total Capacity PI : Power Input
 Indoor air temperature conditions : 20.0°C dry-bulb



MMY-AP4026HT8P-E (40HP, 113.5kW system)

Cooling		Compressor + Outdoor Fan Power consumption (kW)																	
		Outdoor Unit 100% Capacity (kW)		100%		90%		80%		70%		60%		50%		40%		30%	
		TC	PI	TC	PI	TC	PI	TC	PI	TC	PI	TC	PI	TC	PI	TC	PI	TC	PI
Outdoor Unit (°C)	Outdoor Unit 100% Capacity (kW)	105.6	105.6	37.4	95.1	29.6	84.5	23.3	73.9	18.1	63.4	14.0	52.8	10.7	42.3	7.89	31.7	5.44	
40 °C	105.6	105.6	37.4	95.1	29.6	84.5	23.3	73.9	18.1	63.4	14.0	52.8	10.7	42.3	7.89	31.7	5.44		
39 °C	107.3	107.3	36.8	96.6	29.2	85.9	22.9	75.1	17.9	64.4	13.8	53.7	10.5	42.9	7.77	32.2	5.36		
37 °C	110.5	110.5	35.7	99.5	28.3	88.4	22.2	77.4	17.3	66.3	13.4	55.3	10.2	44.2	7.53	33.2	5.20		
35 °C	113.5	113.5	34.6	102.1	27.4	90.8	21.5	79.4	16.8	68.1	13.0	56.7	9.87	45.4	7.30	34.0	5.03		
33 °C	113.5	113.5	31.7	102.2	25.2	90.8	19.9	79.5	15.6	68.1	12.1	56.8	9.23	45.4	6.84	34.1	4.72		
31 °C	113.5	113.5	29.2	102.2	23.3	90.8	18.4	79.5	14.5	68.1	11.3	56.8	8.65	45.4	6.42	34.1	4.43		
30 °C	113.5	113.5	28.0	102.2	22.4	90.8	17.8	79.5	14.0	68.1	10.9	56.8	8.38	45.4	6.23	34.1	4.30		
29 °C	113.5	113.5	27.0	102.2	21.6	90.8	17.1	79.5	13.5	68.1	10.6	56.8	8.12	45.4	6.04	34.1	4.17		
27 °C	113.5	113.5	25.0	102.2	20.0	90.8	16.0	79.5	12.6	68.1	9.91	56.8	7.63	45.4	5.68	34.1	3.92		
25 °C	113.5	113.5	23.2	102.2	18.7	90.8	14.9	79.5	11.8	68.1	9.30	56.8	7.18	45.4	5.35	34.1	3.69		
23 °C	113.5	113.5	22.1	102.2	17.8	90.8	14.3	79.5	11.3	68.1	8.92	56.8	6.90	45.4	5.15	34.1	3.55		
21 °C	113.5	113.5	21.5	102.2	17.4	90.8	14.0	79.5	11.1	68.1	8.77	56.8	6.79	45.4	5.07	34.1	3.49		
20 °C	113.5	113.5	21.3	102.2	17.2	90.8	13.8	79.5	11.0	68.1	8.70	56.8	6.74	45.4	5.04	34.1	3.47		
19 °C	113.5	113.5	21.1	102.2	17.0	90.8	13.7	79.5	10.9	68.1	8.64	56.8	6.70	45.4	5.00	34.1	3.44		
17 °C	113.5	113.5	20.7	102.2	16.7	90.8	13.5	79.5	10.8	68.1	8.52	56.8	6.62	45.4	4.95	34.1	3.40		
15 °C	113.5	113.5	20.3	102.2	16.5	90.8	13.3	79.5	10.6	68.1	8.42	56.8	6.55	45.4	4.89	34.1	3.37		

TC : Total Capacity PI : Power Input
Indoor air temperature conditions : 27.0°C dry-bulb / 19.0°C wet bulb

Heating			Compressor + Outdoor Fan Power consumption (kW)																	
			Outdoor Unit 100% Heating Capacity (kW)		100% Capacity		90% Capacity		80% Capacity		70% Capacity		60% Capacity		50% Capacity		40% Capacity		30% Capacity	
			Dry-Bulb (°C)	Wet-Bulb (°C)	TC	PI	TC	PI	TC	PI	TC	PI	TC	PI	TC	PI	TC	PI	TC	PI
15.0	13.7	127.5	127.5	26.0	114.8	21.6	102.0	17.9	89.3	14.9	76.5	12.3	63.8	10.1	51.0	8.18	38.3	6.32		
13.0	11.8	127.5	127.5	27.3	114.8	22.5	102.0	18.6	89.3	15.3	76.5	12.7	63.8	10.4	51.0	8.35	38.3	6.45		
11.0	9.8	127.5	127.5	28.7	114.8	23.6	102.0	19.4	89.3	15.9	76.5	13.1	63.8	10.7	51.0	8.55	38.3	6.59		
9.0	7.9	127.5	127.5	30.3	114.8	24.7	102.0	20.2	89.3	16.5	76.5	13.5	63.8	10.9	51.0	8.75	38.3	6.74		
7.0	6.0	127.5	127.5	32.0	114.8	26.0	102.0	21.1	89.3	17.1	76.5	13.9	63.8	11.3	51.0	8.97	38.3	6.89		
5.0	4.1	123.3	123.3	31.8	110.9	25.9	98.6	21.0	86.3	17.0	74.0	13.8	61.6	11.2	49.3	8.91	37.0	6.85		
3.0	2.2	119.0	119.0	31.6	107.1	25.7	95.2	20.8	83.3	16.9	71.4	13.7	59.5	11.1	47.6	8.86	35.7	6.80		
0.0	-0.7	112.6	112.6	31.3	101.3	25.4	90.0	20.6	78.8	16.8	67.5	13.6	56.3	11.0	45.0	8.77	33.8	6.74		
-3.0	-3.7	105.9	105.9	31.0	95.3	25.2	84.7	20.4	74.1	16.6	63.5	13.5	52.9	10.9	42.3	8.68	31.8	6.67		
-5.0	-5.6	101.6	101.6	30.8	91.5	25.0	81.3	20.3	71.1	16.5	61.0	13.4	50.8	10.8	40.7	8.63	30.5	6.63		
-7.0	-7.6	97.2	97.2	30.6	87.5	24.8	77.7	20.2	68.0	16.4	58.3	13.3	48.6	10.7	38.9	8.57	29.2	6.58		
-10	-10.5	90.7	90.7	30.3	81.6	24.6	72.6	20.0	63.5	16.2	54.4	13.2	45.4	10.6	36.3	8.48	27.2	6.52		
-14.5	-15.0	80.7	80.7	29.8	72.6	24.2	64.5	19.6	56.5	15.9	48.4	12.9	40.3	10.5	32.3	8.35	24.2	6.41		

TC : Total Capacity PI : Power Input
Indoor air temperature conditions : 20.0°C dry-bulb



MMY-AP4226HT8P-E (42HP, 120kW system)

Outdoor Unit (°C)		Outdoor Unit 100% Capacity (kW)	Compressor + Outdoor Fan Power consumption (kW)															
			100%		90%		80%		70%		60%		50%		40%		30%	
			TC (kW)	PI (kW)	TC (kW)	PI (kW)	TC (kW)	PI (kW)	TC (kW)	PI (kW)	TC (kW)	PI (kW)	TC (kW)	PI (kW)	TC (kW)	PI (kW)	TC (kW)	PI (kW)
40 °C		111.7	111.7	39.9	100.5	31.4	89.3	24.6	78.2	19.2	67.0	14.9	55.8	11.4	44.7	8.46	33.5	5.85
39 °C		113.5	113.5	39.3	102.1	31.0	90.8	24.3	79.4	18.9	68.1	14.6	56.7	11.2	45.4	8.34	34.0	5.77
37 °C		116.9	116.9	38.1	105.2	30.0	93.5	23.5	81.8	18.3	70.1	14.2	58.4	10.9	46.7	8.08	35.1	5.59
35 °C		120.0	120.0	36.9	108.0	29.1	96.0	22.8	84.0	17.8	72.0	13.8	60.0	10.5	48.0	7.83	36.0	5.42
33 °C		120.0	120.0	33.8	108.0	26.7	96.0	21.0	84.0	16.5	72.0	12.8	60.0	9.85	48.0	7.34	36.0	5.08
31 °C		120.0	120.0	31.0	108.0	24.7	96.0	19.5	84.0	15.3	72.0	12.0	60.0	9.24	48.0	6.90	36.0	4.77
30 °C		120.0	120.0	29.8	108.0	23.7	96.0	18.8	84.0	14.8	72.0	11.6	60.0	8.95	48.0	6.69	36.0	4.62
29 °C		120.0	120.0	28.7	108.0	22.8	96.0	18.1	84.0	14.3	72.0	11.2	60.0	8.68	48.0	6.49	36.0	4.48
27 °C		120.0	120.0	26.5	108.0	21.2	96.0	16.9	84.0	13.4	72.0	10.5	60.0	8.16	48.0	6.11	36.0	4.21
25 °C		120.0	120.0	24.7	108.0	19.8	96.0	15.8	84.0	12.5	72.0	9.89	60.0	7.68	48.0	5.75	36.0	3.96
23 °C		120.0	120.0	23.4	108.0	18.8	96.0	15.1	84.0	12.0	72.0	9.49	60.0	7.38	48.0	5.54	36.0	3.81
21 °C		120.0	120.0	22.8	108.0	18.4	96.0	14.8	84.0	11.8	72.0	9.33	60.0	7.27	48.0	5.45	36.0	3.75
20 °C		120.0	120.0	22.6	108.0	18.2	96.0	14.6	84.0	11.7	72.0	9.26	60.0	7.22	48.0	5.42	36.0	3.72
19 °C		120.0	120.0	22.3	108.0	18.0	96.0	14.5	84.0	11.6	72.0	9.19	60.0	7.17	48.0	5.38	36.0	3.70
17 °C		120.0	120.0	21.9	108.0	17.7	96.0	14.3	84.0	11.4	72.0	9.07	60.0	7.08	48.0	5.32	36.0	3.65
15 °C		120.0	120.0	21.6	108.0	17.4	96.0	14.1	84.0	11.3	72.0	8.97	60.0	7.01	48.0	5.27	36.0	3.61

TC : Total Capacity PI : Power Input
Indoor air temperature conditions : 27.0°C dry-bulb / 19.0°C wet bulb

Outdoor Unit Dry-Bulb (°C) Wet-Bulb (°C)			Outdoor Unit 100% Heating Capacity (kW)	Compressor + Outdoor Fan Power consumption (kW)															
				100% Capacity		90% Capacity		80% Capacity		70% Capacity		60% Capacity		50% Capacity		40% Capacity		30% Capacity	
				TC (kW)	PI (kW)	TC (kW)	PI (kW)	TC (kW)	PI (kW)	TC (kW)	PI (kW)	TC (kW)	PI (kW)	TC (kW)	PI (kW)	TC (kW)	PI (kW)	TC (kW)	PI (kW)
15.0	13.7	135.0	135.0	27.2	121.5	22.4	108.0	18.6	94.5	15.4	81.0	12.8	67.5	10.6	54.0	8.67	40.5	6.92	
13.0	11.8	135.0	135.0	28.5	121.5	23.4	108.0	19.3	94.5	15.9	81.0	13.1	67.5	10.8	54.0	8.84	40.5	7.04	
11.0	9.8	135.0	135.0	30.1	121.5	24.6	108.0	20.1	94.5	16.5	81.0	13.5	67.5	11.1	54.0	9.03	40.5	7.17	
9.0	7.9	135.0	135.0	31.7	121.5	25.8	108.0	21.0	94.5	17.1	81.0	13.9	67.5	11.4	54.0	9.22	40.5	7.30	
7.0	6.0	135.0	135.0	33.6	121.5	27.2	108.0	21.9	94.5	17.8	81.0	14.4	67.5	11.7	54.0	9.43	40.5	7.44	
5.0	4.1	130.7	130.7	33.4	117.6	27.0	104.5	21.8	91.5	17.7	78.4	14.3	65.3	11.6	52.3	9.38	39.2	7.40	
3.0	2.2	126.3	126.3	33.2	113.7	26.9	101.0	21.7	88.4	17.6	75.8	14.2	63.2	11.6	50.5	9.32	37.9	7.36	
0.0	-0.7	119.7	119.7	32.9	107.7	26.6	95.7	21.5	83.8	17.4	71.8	14.1	59.8	11.5	47.9	9.24	35.9	7.29	
-3.0	-3.7	112.8	112.8	32.6	101.5	26.4	90.3	21.3	79.0	17.2	67.7	14.0	56.4	11.3	45.1	9.16	33.8	7.22	
-5.0	-5.6	108.5	108.5	32.4	97.6	26.2	86.8	21.2	75.9	17.1	65.1	13.9	54.2	11.3	43.4	9.10	32.5	7.18	
-7.0	-7.6	103.9	103.9	32.2	93.5	26.1	83.1	21.1	72.7	17.0	62.4	13.8	52.0	11.2	41.6	9.05	31.2	7.14	
-10	-10.5	97.3	97.3	31.9	87.6	25.8	77.8	20.9	68.1	16.9	58.4	13.7	48.6	11.1	38.9	8.96	29.2	7.07	
-14.5	-15.0	87.0	87.0	31.5	78.3	25.4	69.6	20.6	60.9	16.6	52.2	13.5	43.5	10.9	34.8	8.84	26.1	6.97	

TC : Total Capacity PI : Power Input
Indoor air temperature conditions : 20.0°C dry-bulb



MMY-AP4426HT8P-E (44HP, 125kW system)

Outdoor Unit (°C)		Outdoor Unit 100% Capacity (kW)	Compressor + Outdoor Fan Power consumption (kW)															
			100%		90%		80%		70%		60%		50%		40%		30%	
			TC (kW)	PI (kW)	TC (kW)	PI (kW)	TC (kW)	PI (kW)	TC (kW)	PI (kW)	TC (kW)	PI (kW)	TC (kW)	PI (kW)	TC (kW)	PI (kW)	TC (kW)	PI (kW)
40 °C	116.3	116.3	42.0	104.7	33.3	93.1	26.1	81.4	20.3	69.8	15.7	58.2	11.9	46.5	8.74	34.9	5.98	
39 °C	118.2	118.2	41.4	106.4	32.8	94.6	25.7	82.7	20.0	70.9	15.4	59.1	11.7	47.3	8.62	35.5	5.89	
37 °C	121.7	121.7	40.2	109.6	31.8	97.4	24.9	85.2	19.4	73.0	15.0	60.9	11.4	48.7	8.35	36.5	5.71	
35 °C	125.0	125.0	38.9	112.5	30.8	100.0	24.2	87.5	18.8	75.0	14.5	62.5	11.0	50.0	8.09	37.5	5.53	
33 °C	125.0	125.0	35.6	112.5	28.3	100.0	22.3	87.5	17.4	75.0	13.5	62.5	10.3	50.0	7.58	37.5	5.18	
31 °C	125.0	125.0	32.8	112.5	26.1	100.0	20.7	87.5	16.2	75.0	12.6	62.5	9.64	50.0	7.12	37.5	4.86	
30 °C	125.0	125.0	31.5	112.5	25.1	100.0	19.9	87.5	15.7	75.0	12.2	62.5	9.33	50.0	6.90	37.5	4.71	
29 °C	125.0	125.0	30.3	112.5	24.2	100.0	19.2	87.5	15.1	75.0	11.8	62.5	9.04	50.0	6.69	37.5	4.57	
27 °C	125.0	125.0	28.1	112.5	22.5	100.0	17.9	87.5	14.2	75.0	11.1	62.5	8.50	50.0	6.29	37.5	4.29	
25 °C	125.0	125.0	26.1	112.5	21.0	100.0	16.7	87.5	13.2	75.0	10.4	62.5	7.99	50.0	5.92	37.5	4.04	
23 °C	125.0	125.0	24.8	112.5	20.0	100.0	16.0	87.5	12.7	75.0	10.0	62.5	7.68	50.0	5.69	37.5	3.88	
21 °C	125.0	125.0	24.2	112.5	19.5	100.0	15.6	87.5	12.4	75.0	9.79	62.5	7.55	50.0	5.60	37.5	3.82	
20 °C	125.0	125.0	23.9	112.5	19.3	100.0	15.5	87.5	12.3	75.0	9.71	62.5	7.50	50.0	5.57	37.5	3.79	
19 °C	125.0	125.0	23.7	112.5	19.1	100.0	15.3	87.5	12.2	75.0	9.64	62.5	7.44	50.0	5.53	37.5	3.76	
17 °C	125.0	125.0	23.2	112.5	18.8	100.0	15.1	87.5	12.1	75.0	9.51	62.5	7.35	50.0	5.46	37.5	3.72	
15 °C	125.0	125.0	22.8	112.5	18.5	100.0	14.9	87.5	11.9	75.0	9.40	62.5	7.27	50.0	5.41	37.5	3.68	

TC : Total Capacity PI : Power Input
Indoor air temperature conditions : 27.0°C dry-bulb / 19.0°C wet bulb

Outdoor Unit Dry-Bulb (°C) Wet-Bulb (°C)			Outdoor Unit 100% Heating Capacity (kW)	Compressor + Outdoor Fan Power consumption (kW)															
				100% Capacity		90% Capacity		80% Capacity		70% Capacity		60% Capacity		50% Capacity		40% Capacity		30% Capacity	
				TC (kW)	PI (kW)	TC (kW)	PI (kW)	TC (kW)	PI (kW)	TC (kW)	PI (kW)	TC (kW)	PI (kW)	TC (kW)	PI (kW)	TC (kW)	PI (kW)	TC (kW)	PI (kW)
15.0	13.7	140.0	140.0	28.7	126.0	23.8	112.0	19.7	98.0	16.3	84.0	13.5	70.0	11.1	56.0	9.05	42.0	7.23	
13.0	11.8	140.0	140.0	30.1	126.0	24.8	112.0	20.5	98.0	16.8	84.0	13.8	70.0	11.3	56.0	9.22	42.0	7.35	
11.0	9.8	140.0	140.0	31.7	126.0	26.0	112.0	21.3	98.0	17.5	84.0	14.3	70.0	11.6	56.0	9.43	42.0	7.48	
9.0	7.9	140.0	140.0	33.4	126.0	27.3	112.0	22.3	98.0	18.1	84.0	14.7	70.0	12.0	56.0	9.63	42.0	7.62	
7.0	6.0	140.0	140.0	35.3	126.0	28.7	112.0	23.3	98.0	18.8	84.0	15.2	70.0	12.3	56.0	9.86	42.0	7.76	
5.0	4.1	135.3	135.3	35.1	121.8	28.5	108.2	23.1	94.7	18.7	81.2	15.1	67.7	12.2	54.1	9.79	40.6	7.71	
3.0	2.2	130.6	130.6	34.8	117.6	28.3	104.5	23.0	91.4	18.6	78.4	15.0	65.3	12.1	52.2	9.73	39.2	7.66	
0.0	-0.7	123.5	123.5	34.5	111.1	28.1	98.8	22.7	86.4	18.4	74.1	14.9	61.7	12.0	49.4	9.63	37.0	7.59	
-3.0	-3.7	116.1	116.1	34.1	104.5	27.8	92.9	22.5	81.3	18.2	69.6	14.7	58.0	11.9	46.4	9.53	34.8	7.51	
-5.0	-5.6	111.4	111.4	33.9	100.3	27.6	89.1	22.4	78.0	18.1	66.8	14.6	55.7	11.8	44.6	9.47	33.4	7.46	
-7.0	-7.6	106.5	106.5	33.7	95.8	27.4	85.2	22.2	74.5	18.0	63.9	14.5	53.2	11.7	42.6	9.40	31.9	7.41	
-10	-10.5	99.3	99.3	33.3	89.4	27.1	79.5	22.0	69.5	17.8	59.6	14.4	49.7	11.6	39.7	9.31	29.8	7.33	
-14.5	-15.0	88.2	88.2	32.8	79.4	26.7	70.6	21.6	61.8	17.5	52.9	14.2	44.1	11.4	35.3	9.16	26.5	7.21	

TC : Total Capacity PI : Power Input
Indoor air temperature conditions : 20.0°C dry-bulb



MMY-AP5426HT8P-E (54HP, 152kW system)

Cooling		Compressor + Outdoor Fan Power consumption (kW)																	
		Outdoor Unit 100% Capacity (kW)		100%		90%		80%		70%		60%		50%		40%		30%	
		TC (kW)	PI (kW)	TC (kW)	PI (kW)	TC (kW)	PI (kW)	TC (kW)	PI (kW)	TC (kW)	PI (kW)	TC (kW)	PI (kW)	TC (kW)	PI (kW)	TC (kW)	PI (kW)	TC (kW)	PI (kW)
40 °C	141.5	141.5	50.7	127.3	40.6	113.2	32.2	99.0	25.4	84.9	19.7	70.7	15.0	56.6	11.1	42.4	7.55		
39 °C	143.7	143.7	49.9	129.4	40.0	115.0	31.8	100.6	25.0	86.2	19.4	71.9	14.8	57.5	10.9	43.1	7.44		
37 °C	148.0	148.0	48.4	133.2	38.8	118.4	30.8	103.6	24.2	88.8	18.8	74.0	14.4	59.2	10.6	44.4	7.22		
35 °C	152.0	152.0	46.9	136.8	37.5	121.6	29.8	106.4	23.5	91.2	18.2	76.0	13.9	60.8	10.2	45.6	6.99		
33 °C	152.0	152.0	43.1	136.8	34.6	121.6	27.6	106.4	21.8	91.2	17.0	76.0	13.0	60.8	9.60	45.6	6.55		
31 °C	152.0	152.0	39.7	136.8	32.0	121.6	25.6	106.4	20.3	91.2	15.9	76.0	12.2	60.8	9.01	45.6	6.14		
30 °C	152.0	152.0	38.2	136.8	30.9	121.6	24.7	106.4	19.6	91.2	15.4	76.0	11.8	60.8	8.73	45.6	5.95		
29 °C	152.0	152.0	36.8	136.8	29.7	121.6	23.9	106.4	19.0	91.2	14.9	76.0	11.4	60.8	8.47	45.6	5.77		
27 °C	152.0	152.0	34.2	136.8	27.7	121.6	22.3	106.4	17.7	91.2	14.0	76.0	10.8	60.8	7.96	45.6	5.42		
25 °C	152.0	152.0	31.8	136.8	25.8	121.6	20.8	106.4	16.6	91.2	13.1	76.0	10.1	60.8	7.49	45.6	5.10		
23 °C	152.0	152.0	30.3	136.8	24.6	121.6	19.9	106.4	15.9	91.2	12.6	76.0	9.72	60.8	7.21	45.6	4.90		
21 °C	152.0	152.0	29.6	136.8	24.1	121.6	19.5	106.4	15.6	91.2	12.4	76.0	9.56	60.8	7.09	45.6	4.82		
20 °C	152.0	152.0	29.3	136.8	23.9	121.6	19.3	106.4	15.5	91.2	12.3	76.0	9.49	60.8	7.04	45.6	4.78		
19 °C	152.0	152.0	29.0	136.8	23.6	121.6	19.1	106.4	15.4	91.2	12.2	76.0	9.43	60.8	7.00	45.6	4.75		
17 °C	152.0	152.0	28.4	136.8	23.2	121.6	18.9	106.4	15.2	91.2	12.0	76.0	9.31	60.8	6.91	45.6	4.69		
15 °C	152.0	152.0	28.0	136.8	22.9	121.6	18.6	106.4	15.0	91.2	11.9	76.0	9.21	60.8	6.84	45.6	4.64		

TC : Total Capacity PI : Power Input
Indoor air temperature conditions : 27.0°C dry-bulb / 19.0°C wet bulb

Heating			Compressor + Outdoor Fan Power consumption (kW)																	
			Outdoor Unit 100% Heating Capacity (kW)		100% Capacity		90% Capacity		80% Capacity		70% Capacity		60% Capacity		50% Capacity		40% Capacity		30% Capacity	
			Dry-Bulb (°C)	Wet-Bulb (°C)	TC (kW)	PI (kW)	TC (kW)	PI (kW)	TC (kW)	PI (kW)	TC (kW)	PI (kW)	TC (kW)	PI (kW)	TC (kW)	PI (kW)	TC (kW)	PI (kW)	TC (kW)	PI (kW)
15.0	13.7	171.0	171.0	37.4	153.9	31.5	136.8	26.3	119.7	21.9	102.6	18.0	85.5	14.6	68.4	11.4	51.3	8.34		
13.0	11.8	171.0	171.0	39.1	153.9	32.7	136.8	27.3	119.7	22.6	102.6	18.6	85.5	15.0	68.4	11.7	51.3	8.56		
11.0	9.8	171.0	171.0	41.0	153.9	34.2	136.8	28.4	119.7	23.4	102.6	19.2	85.5	15.4	68.4	12.0	51.3	8.80		
9.0	7.9	171.0	171.0	43.0	153.9	35.7	136.8	29.5	119.7	24.3	102.6	19.8	85.5	15.9	68.4	12.4	51.3	9.04		
7.0	6.0	171.0	171.0	45.2	153.9	37.4	136.8	30.8	119.7	25.2	102.6	20.5	85.5	16.4	68.4	12.7	51.3	9.30		
5.0	4.1	165.0	165.0	44.9	148.5	37.1	132.0	30.6	115.5	25.0	99.0	20.3	82.5	16.3	66.0	12.6	49.5	9.24		
3.0	2.2	159.1	159.1	44.5	143.2	36.8	127.3	30.3	111.4	24.9	95.4	20.2	79.5	16.1	63.6	12.5	47.7	9.17		
0.0	-0.7	150.0	150.0	44.1	135.0	36.4	120.0	30.0	105.0	24.6	90.0	20.0	75.0	16.0	60.0	12.4	45.0	9.07		
-3.0	-3.7	140.6	140.6	43.5	126.5	36.0	112.5	29.7	98.4	24.3	84.3	19.7	70.3	15.8	56.2	12.3	42.2	8.97		
-5.0	-5.6	134.6	134.6	43.2	121.2	35.8	107.7	29.4	94.2	24.1	80.8	19.6	67.3	15.7	53.8	12.2	40.4	8.90		
-7.0	-7.6	128.3	128.3	42.9	115.5	35.5	102.7	29.2	89.8	23.9	77.0	19.4	64.2	15.5	51.3	12.1	38.5	8.83		
-10	-10.5	119.2	119.2	42.4	107.3	35.1	95.4	28.9	83.5	23.6	71.5	19.2	59.6	15.4	47.7	11.9	35.8	8.73		
-14.5	-15.0	105.1	105.1	41.6	94.6	34.4	84.1	28.4	73.6	23.2	63.1	18.9	52.6	15.1	42.1	11.7	31.5	8.57		

TC : Total Capacity PI : Power Input
Indoor air temperature conditions : 20.0°C dry-bulb



MMY-SAP0806HT8P-E (8HP, 22.4kW system)

Outdoor Unit Dry-Bulb (°C)		Outdoor Unit 100% Cooling Capacity (kW)	Compressor + Outdoor Fan Power consumption (kW)															
			100% Capacity		90% Capacity		80% Capacity		70% Capacity		60% Capacity		50% Capacity		40% Capacity		30% Capacity	
			TC (kW)	PI (kW)	TC (kW)	PI (kW)	TC (kW)	PI (kW)	TC (kW)	PI (kW)	TC (kW)	PI (kW)	TC (kW)	PI (kW)	TC (kW)	PI (kW)	TC (kW)	PI (kW)
40 °C	20.8	20.8	5.99	18.8	4.85	16.7	3.89	14.6	3.09	12.5	2.43	10.4	1.89	8.34	1.47	6.25	1.15	
39 °C	21.2	21.2	5.90	19.1	4.78	16.9	3.84	14.8	3.04	12.7	2.39	10.6	1.87	8.47	1.45	6.35	1.13	
37 °C	21.8	21.8	5.72	19.6	4.64	17.5	3.72	15.3	2.95	13.1	2.32	10.9	1.81	8.73	1.41	6.54	1.10	
35 °C	22.4	22.4	5.54	20.2	4.49	17.9	3.60	15.7	2.86	13.4	2.25	11.2	1.75	8.96	1.36	6.72	1.06	
32 °C	22.4	22.4	5.10	20.2	4.15	17.9	3.34	15.7	2.66	13.4	2.10	11.2	1.65	8.96	1.29	6.72	1.01	
31 °C	22.4	22.4	4.72	20.2	3.85	17.9	3.10	15.7	2.48	13.4	1.97	11.2	1.55	8.96	1.22	6.72	0.96	
30 °C	22.4	22.4	4.55	20.2	3.71	17.9	3.00	15.7	2.40	13.4	1.90	11.2	1.50	8.96	1.18	6.72	0.94	
29 °C	22.4	22.4	4.38	20.2	3.58	17.9	2.89	15.7	2.32	13.4	1.84	11.2	1.46	8.96	1.15	6.72	0.91	
27 °C	22.4	22.4	4.08	20.2	3.34	17.9	2.70	15.7	2.17	13.4	1.73	11.2	1.38	8.96	1.09	6.72	0.87	
25 °C	22.4	22.4	3.80	20.2	3.11	17.9	2.53	15.7	2.04	13.4	1.63	11.2	1.30	8.96	1.03	6.72	0.83	
23 °C	22.4	22.4	3.62	20.2	2.97	17.9	2.42	15.7	1.95	13.4	1.57	11.2	1.25	8.96	1.00	6.72	0.80	
21 °C	22.4	22.4	3.54	20.2	2.91	17.9	2.37	15.7	1.92	13.4	1.54	11.2	1.23	8.96	0.99	6.72	0.80	
20 °C	22.4	22.4	3.51	20.2	2.88	17.9	2.35	15.7	1.90	13.4	1.53	11.2	1.23	8.96	0.98	6.72	0.79	
19 °C	22.4	22.4	3.47	20.2	2.86	17.9	2.33	15.7	1.89	13.4	1.52	11.2	1.22	8.96	0.98	6.72	0.79	
17 °C	22.4	22.4	3.41	20.2	2.81	17.9	2.30	15.7	1.86	13.4	1.50	11.2	1.21	8.96	0.97	6.72	0.79	
15 °C	22.4	22.4	3.36	20.2	2.77	17.9	2.27	15.7	1.84	13.4	1.49	11.2	1.20	8.96	0.97	6.72	0.78	

TC : Total Capacity PI : Power Input
Indoor air temperature conditions : 27.0°C dry-bulb / 19.0°C wet bulb

Outdoor Unit Dry-Bulb/Wet-Bulb (°C) (°C)		Outdoor Unit 100% Heating Capacity (kW)	Compressor + Outdoor Fan Power consumption (kW)															
			100% Capacity		90% Capacity		80% Capacity		70% Capacity		60% Capacity		50% Capacity		40% Capacity		30% Capacity	
			TC (kW)	PI (kW)	TC (kW)	PI (kW)	TC (kW)	PI (kW)	TC (kW)	PI (kW)	TC (kW)	PI (kW)	TC (kW)	PI (kW)	TC (kW)	PI (kW)	TC (kW)	PI (kW)
15.0	13.7	25.0	4.57	22.5	3.79	20.0	3.14	17.5	2.61	15.0	2.17	12.5	1.79	10.0	1.46	7.50	1.15	
13.0	11.8	25.0	4.80	22.5	3.95	20.0	3.26	17.5	2.69	15.0	2.22	12.5	1.83	10.0	1.49	7.50	1.17	
11.0	9.8	25.0	5.06	22.5	4.14	20.0	3.40	17.5	2.79	15.0	2.29	12.5	1.88	10.0	1.52	7.50	1.19	
9.0	7.9	25.0	5.34	22.5	4.35	20.0	3.54	17.5	2.89	15.0	2.36	12.5	1.93	10.0	1.56	7.50	1.22	
7.0	6.0	25.0	5.65	22.5	4.57	20.0	3.70	17.5	3.00	15.0	2.44	12.5	1.98	10.0	1.59	7.50	1.24	
5.0	4.1	24.3	5.63	21.8	4.56	19.4	3.69	17.0	2.99	14.6	2.43	12.1	1.98	9.7	1.59	7.28	1.24	
3.0	2.2	23.5	5.62	21.2	4.55	18.8	3.68	16.5	2.99	14.1	2.43	11.8	1.97	9.4	1.58	7.06	1.23	
0.0	-0.7	22.4	5.59	20.2	4.53	17.9	3.66	15.7	2.97	13.5	2.41	11.2	1.96	9.0	1.58	6.73	1.23	
-3.0	-3.7	21.3	5.56	19.1	4.50	17.0	3.65	14.9	2.96	12.8	2.40	10.6	1.95	8.5	1.57	6.38	1.22	
-5.0	-5.6	20.5	5.54	18.5	4.49	16.4	3.63	14.4	2.95	12.3	2.40	10.3	1.95	8.2	1.56	6.16	1.22	
-7.0	-7.6	19.8	5.53	17.8	4.47	15.8	3.62	13.8	2.94	11.9	2.39	9.9	1.94	7.9	1.56	5.93	1.21	
-10	-10.5	18.7	5.50	16.8	4.45	14.9	3.61	13.1	2.92	11.2	2.38	9.3	1.93	7.5	1.55	5.60	1.21	
-14.5	-15.0	16.9	5.46	15.2	4.42	13.5	3.58	11.8	2.90	10.2	2.36	8.5	1.92	6.8	1.54	5.08	1.20	

TC : Total Capacity PI : Power Input
Indoor air temperature conditions : 20.0°C dry-bulb



MMY-SAP1206HT8P-E (12HP, 33.5kW system)

Cooling

Outdoor Unit Dry-Bulb (°C)	Outdoor Unit 100% Cooling Capacity (kW)	Compressor + Outdoor Fan Power consumption (kW)															
		100% Capacity		90% Capacity		80% Capacity		70% Capacity		60% Capacity		50% Capacity		40% Capacity		30% Capacity	
		TC	PI	TC	PI	TC	PI	TC	PI	TC	PI	TC	PI	TC	PI	TC	PI
		(kW)	(kW)	(kW)	(kW)	(kW)	(kW)	(kW)	(kW)	(kW)	(kW)	(kW)	(kW)	(kW)	(kW)	(kW)	(kW)
40 °C	31.2	31.2	11.13	28.1	8.91	24.9	7.05	21.8	5.51	18.7	4.23	15.6	3.18	12.5	2.31	9.35	1.58
39 °C	31.7	31.7	10.96	28.5	8.78	25.3	6.95	22.2	5.43	19.0	4.17	15.8	3.13	12.7	2.28	9.50	1.56
37 °C	32.6	32.6	10.63	29.4	8.52	26.1	6.74	22.8	5.26	19.6	4.04	16.3	3.04	13.0	2.21	9.79	1.51
35 °C	33.5	33.5	10.29	30.1	8.25	26.8	6.53	23.4	5.10	20.1	3.91	16.7	2.94	13.4	2.14	10.05	1.46
32 °C	33.5	33.5	9.46	30.2	7.60	26.8	6.03	23.5	4.73	20.1	3.64	16.8	2.75	13.4	2.00	10.05	1.37
31 °C	33.5	33.5	8.73	30.2	7.03	26.8	5.60	23.5	4.40	20.1	3.40	16.8	2.57	13.4	1.88	10.05	1.29
30 °C	33.5	33.5	8.40	30.2	6.77	26.8	5.39	23.5	4.24	20.1	3.28	16.8	2.49	13.4	1.82	10.05	1.25
29 °C	33.5	33.5	8.09	30.2	6.52	26.8	5.20	23.5	4.10	20.1	3.18	16.8	2.41	13.4	1.76	10.05	1.22
27 °C	33.5	33.5	7.51	30.2	6.07	26.8	4.85	23.5	3.83	20.1	2.97	16.8	2.26	13.4	1.66	10.05	1.14
25 °C	33.5	33.5	6.99	30.2	5.66	26.8	4.53	23.5	3.58	20.1	2.79	16.8	2.12	13.4	1.56	10.05	1.08
23 °C	33.5	33.5	6.65	30.2	5.40	26.8	4.33	23.5	3.43	20.1	2.67	16.8	2.04	13.4	1.50	10.05	1.04
21 °C	33.5	33.5	6.49	30.2	5.27	26.8	4.24	23.5	3.36	20.1	2.63	16.8	2.00	13.4	1.48	10.05	1.02
20 °C	33.5	33.5	6.42	30.2	5.22	26.8	4.20	23.5	3.33	20.1	2.60	16.8	1.99	13.4	1.47	10.05	1.02
19 °C	33.5	33.5	6.36	30.2	5.17	26.8	4.16	23.5	3.30	20.1	2.58	16.8	1.98	13.4	1.46	10.05	1.01
17 °C	33.5	33.5	6.24	30.2	5.08	26.8	4.09	23.5	3.25	20.1	2.55	16.8	1.95	13.4	1.44	10.05	1.00
15 °C	33.5	33.5	6.14	30.2	5.00	26.8	4.03	23.5	3.21	20.1	2.52	16.8	1.93	13.4	1.43	10.05	0.99

TC : Total Capacity PI : Power Input
Indoor air temperature conditions : 27.0°C dry-bulb / 19.0°C wet bulb

Heating

Outdoor Unit Dry-Bulb / Wet-Bulb (°C) / (°C)		Outdoor Unit 100% Heating Capacity (kW)	Compressor + Outdoor Fan Power consumption (kW)															
			100% Capacity		90% Capacity		80% Capacity		70% Capacity		60% Capacity		50% Capacity		40% Capacity		30% Capacity	
			TC	PI	TC	PI	TC	PI	TC	PI	TC	PI	TC	PI	TC	PI	TC	PI
			(kW)	(kW)	(kW)	(kW)	(kW)	(kW)	(kW)	(kW)	(kW)	(kW)	(kW)	(kW)	(kW)	(kW)	(kW)	(kW)
15.0	13.7	37.5	37.5	8.00	33.8	6.70	30.0	5.60	26.3	4.66	22.5	3.85	18.8	3.12	15.0	2.42	11.3	1.72
13.0	11.8	37.5	37.5	8.37	33.8	6.97	30.0	5.80	26.3	4.81	22.5	3.96	18.8	3.20	15.0	2.49	11.3	1.77
11.0	9.8	37.5	37.5	8.80	33.8	7.29	30.0	6.03	26.3	4.98	22.5	4.09	18.8	3.30	15.0	2.56	11.3	1.83
9.0	7.9	37.5	37.5	9.25	33.8	7.63	30.0	6.28	26.3	5.16	22.5	4.22	18.8	3.39	15.0	2.64	11.3	1.89
7.0	6.0	37.5	37.5	9.76	33.8	8.00	30.0	6.55	26.3	5.36	22.5	4.36	18.8	3.50	15.0	2.71	11.3	1.95
5.0	4.1	36.2	36.2	9.68	32.5	7.94	28.9	6.50	25.3	5.32	21.7	4.33	18.1	3.47	14.5	2.69	10.8	1.94
3.0	2.2	34.8	34.8	9.61	31.3	7.88	27.9	6.45	24.4	5.28	20.9	4.30	17.4	3.45	13.9	2.67	10.4	1.92
0.0	-0.7	32.8	32.8	9.50	29.5	7.79	26.2	6.38	22.9	5.22	19.7	4.24	16.4	3.41	13.1	2.64	9.8	1.90
-3.0	-3.7	30.6	30.6	9.38	27.6	7.69	24.5	6.30	21.5	5.15	18.4	4.19	15.3	3.36	12.3	2.61	9.2	1.87
-5.0	-5.6	29.3	29.3	9.31	26.4	7.63	23.4	6.25	20.5	5.11	17.6	4.16	14.7	3.34	11.7	2.59	8.8	1.86
-7.0	-7.6	27.9	27.9	9.23	25.1	7.57	22.3	6.20	19.5	5.07	16.7	4.12	13.9	3.31	11.2	2.57	8.4	1.84
-10	-10.5	25.8	25.8	9.12	23.3	7.47	20.7	6.12	18.1	5.01	15.5	4.07	12.9	3.27	10.3	2.54	7.8	1.82
-14.5	-15.0	22.7	22.7	8.94	20.4	7.33	18.1	6.00	15.9	4.91	13.6	4.00	11.3	3.21	9.1	2.49	6.8	1.79

TC : Total Capacity PI : Power Input
Indoor air temperature conditions : 20.0°C dry-bulb



5-10. Sound pressure level data

Outdoor Unit

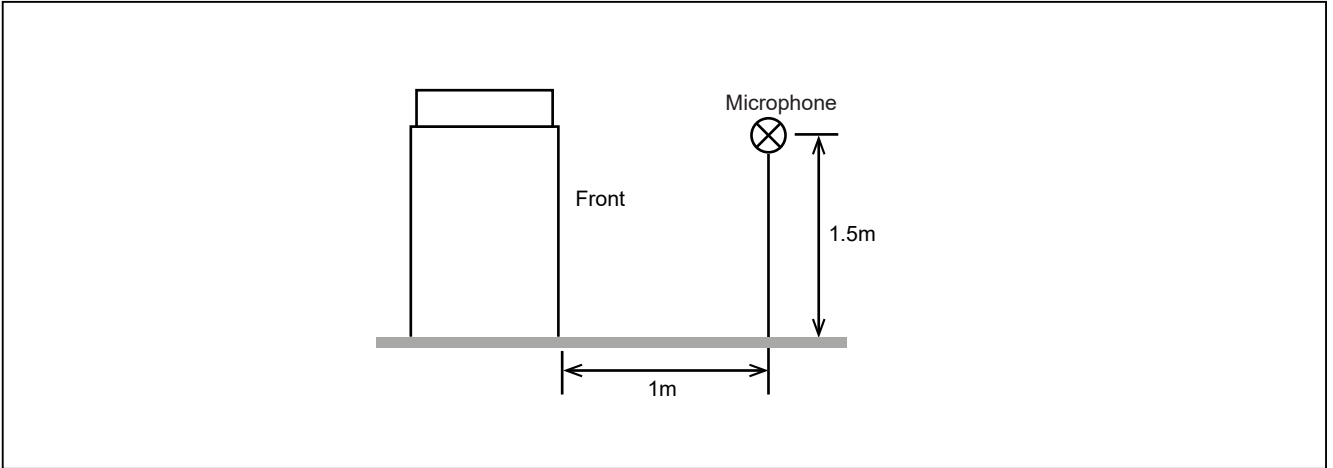

Standard model, Stand alone model

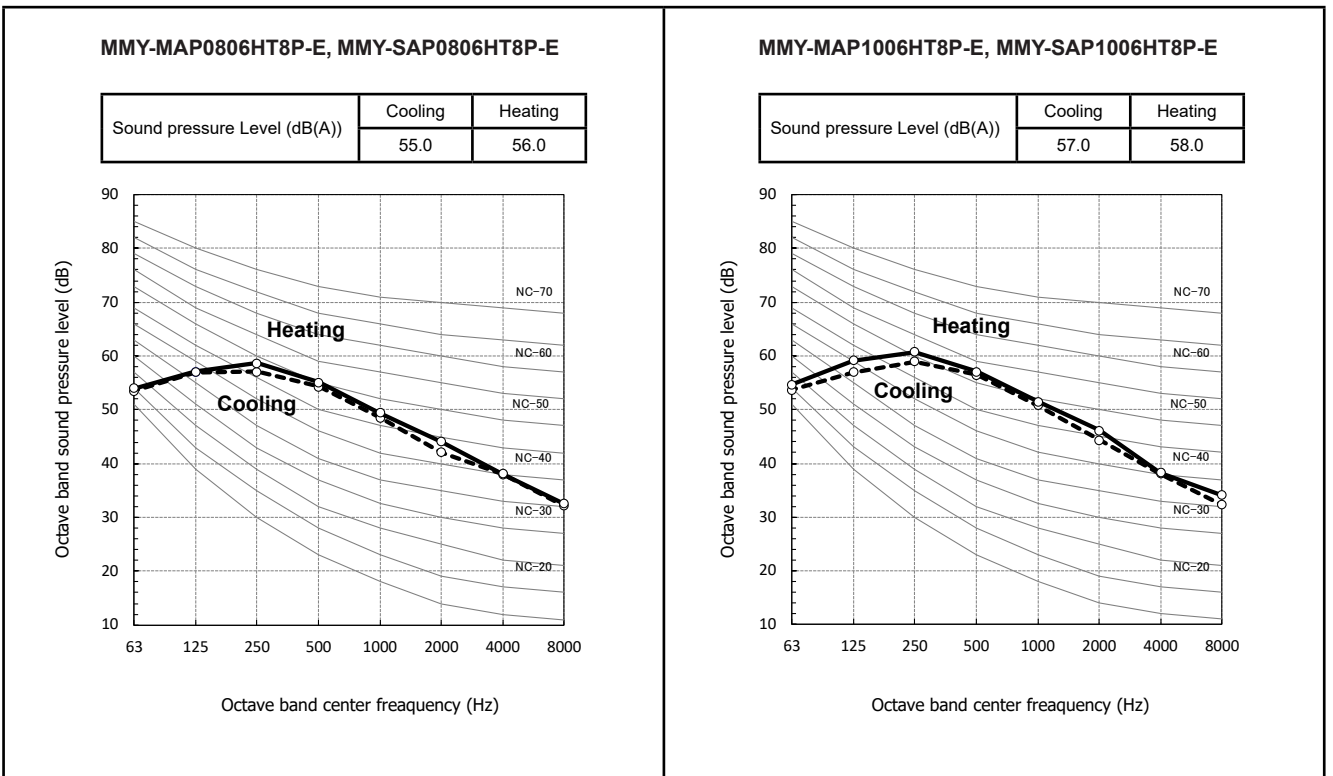



MMY-MAP1206HT8P-E, MMY-SAP1206HT8P-E

Sound pressure Level (dB(A))	Cooling	Heating
	59.0	61.0

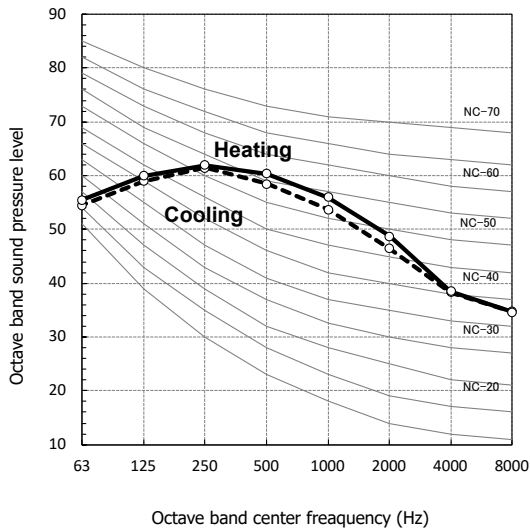

MMY-MAP1406HT8P-E

Sound pressure Level (dB(A))	Cooling	Heating
	60.0	62.0

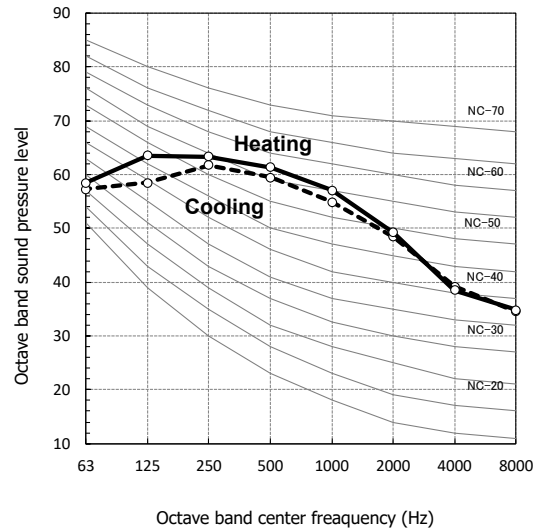

MMY-MAP1604HT8P-E

Sound pressure Level (dB(A))	Cooling	Heating
	62.0	64.0

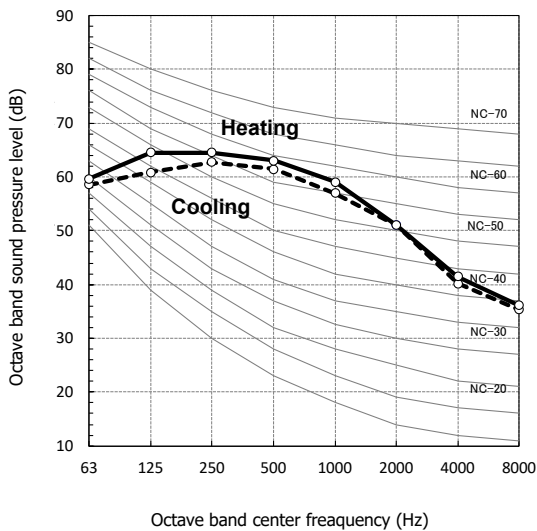

MMY-MAP1806HT8P-E

Sound pressure Level (dB(A))	Cooling	Heating
	60.0	61.0

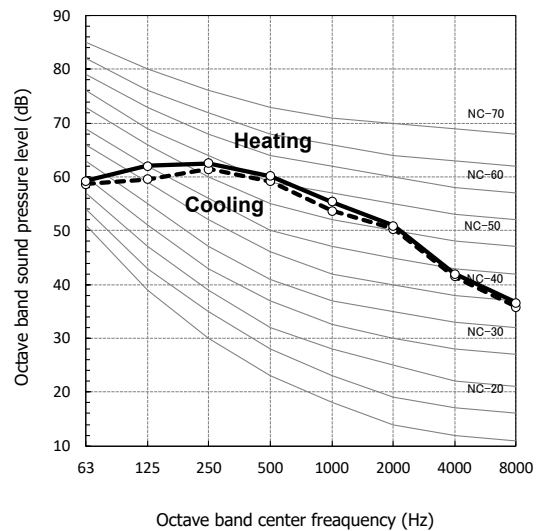



MMY-MAP2006HT8P-E

Sound pressure Level (dB(A))	Cooling	Heating
	61.0	62.0

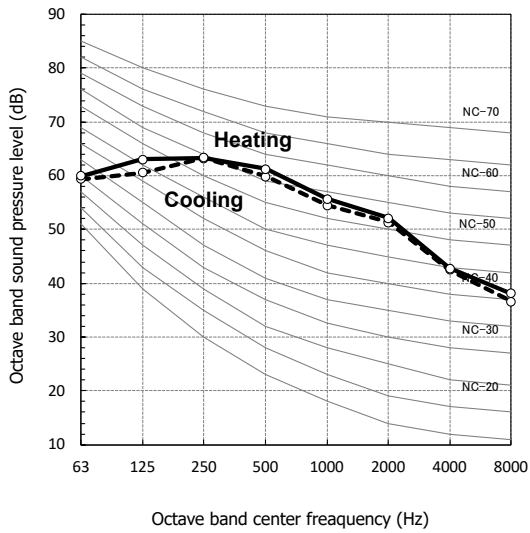

MMY-MAP2206HT8P-E

Sound pressure Level (dB(A))	Cooling	Heating
	61.0	62.0

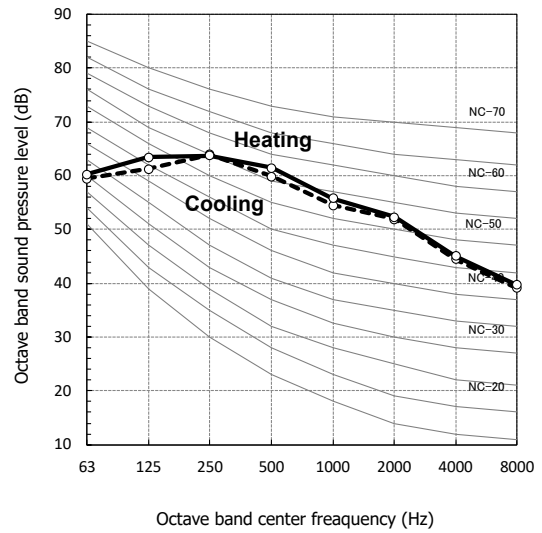

MMY-AP2416HT8P-E

Sound pressure Level (dB(A))	Cooling	Heating
	62.0	64.0

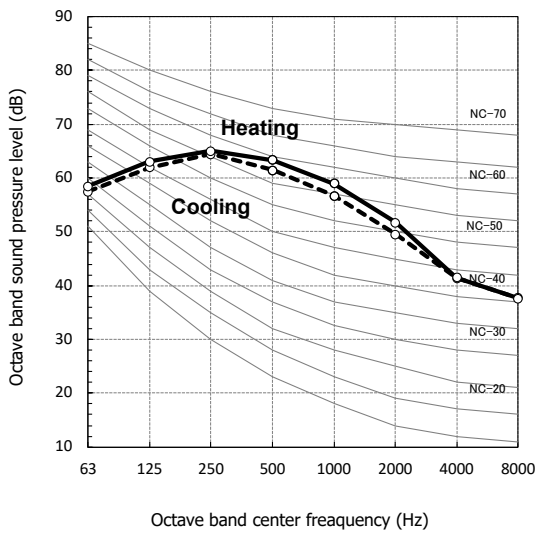

MMY-AP2616HT8P-E

Sound pressure Level (dB(A))	Cooling	Heating
	62.5	64.5

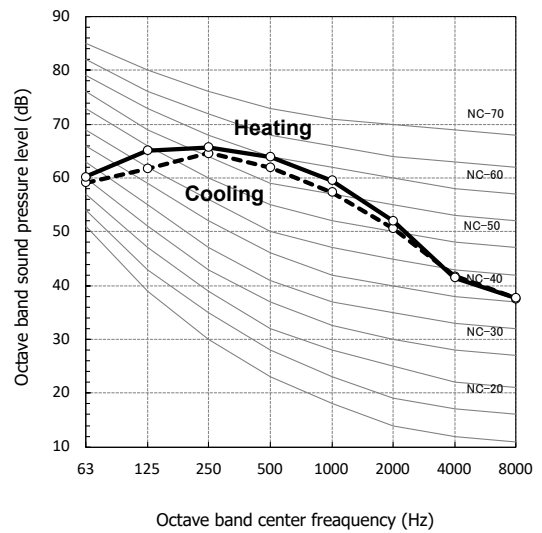



MMY-AP2816HT8P-E

Sound pressure Level (dB(A))	Cooling	Heating
	64.0	66.0

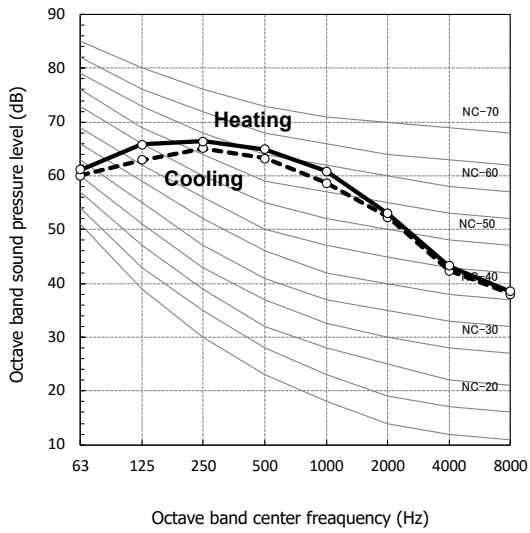

MMY-AP3016HT8P-E

Sound pressure Level (dB(A))	Cooling	Heating
	64.5	66.5

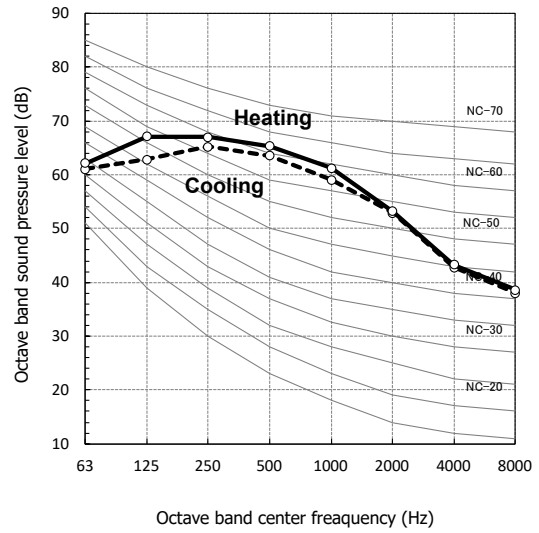

MMY-AP3216HT8P-E

Sound pressure Level (dB(A))	Cooling	Heating
	65.0	67.0

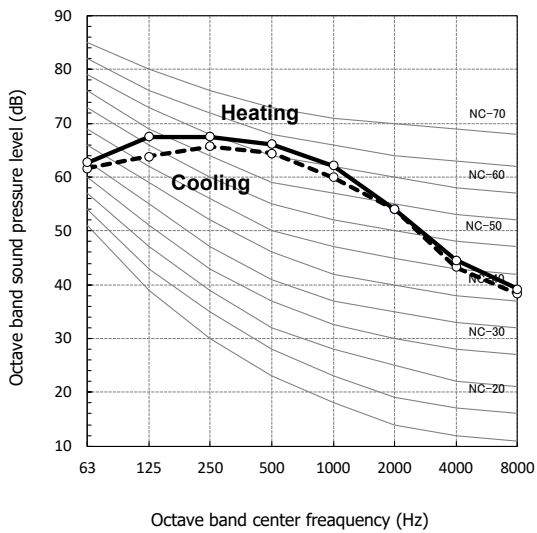

MMY-AP3416HT8P-E

Sound pressure Level (dB(A))	Cooling	Heating
	64.5	66.0

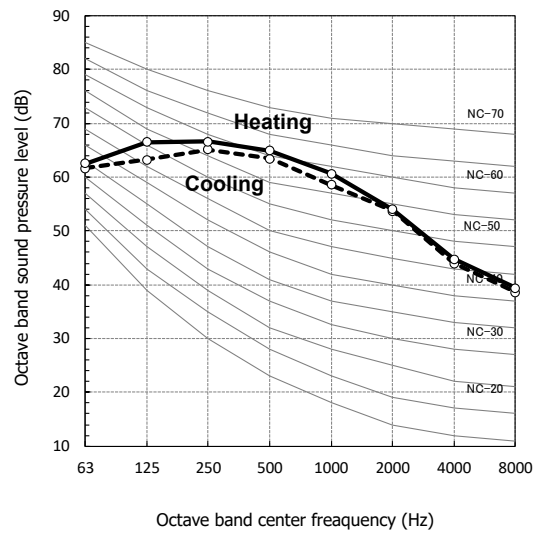



MMY-AP3616HT8P-E

Sound pressure Level (dB(A))	Cooling	Heating
	64.5	66.5

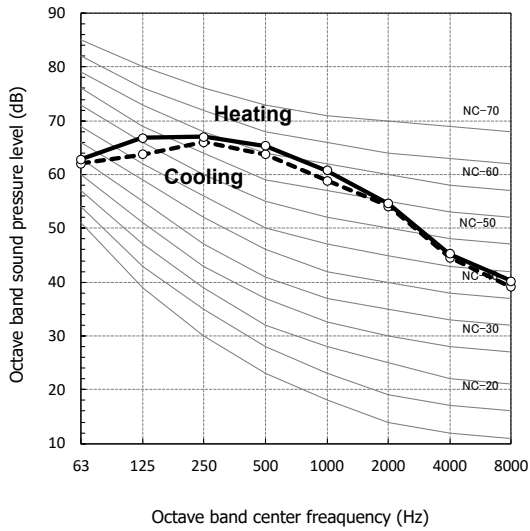

MMY-AP3816HT8P-E

Sound pressure Level (dB(A))	Cooling	Heating
	64.5	66.5

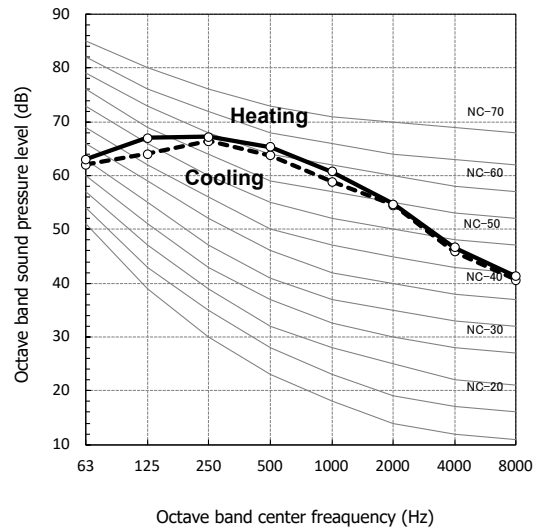

MMY-AP4016HT8P-E

Sound pressure Level (dB(A))	Cooling	Heating
	64.0	65.0

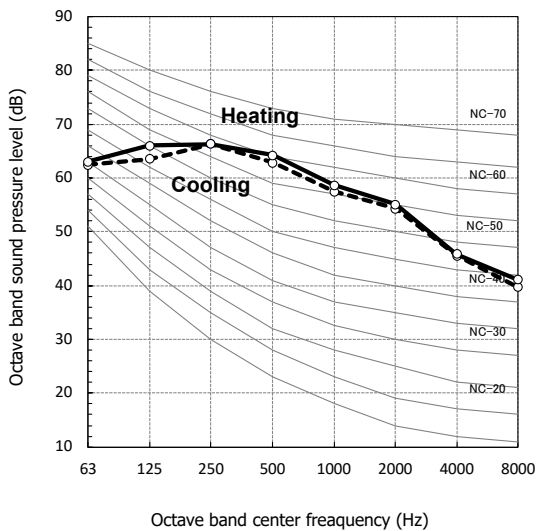

MMY-AP4216HT8P-E

Sound pressure Level (dB(A))	Cooling	Heating
	64.0	65.0

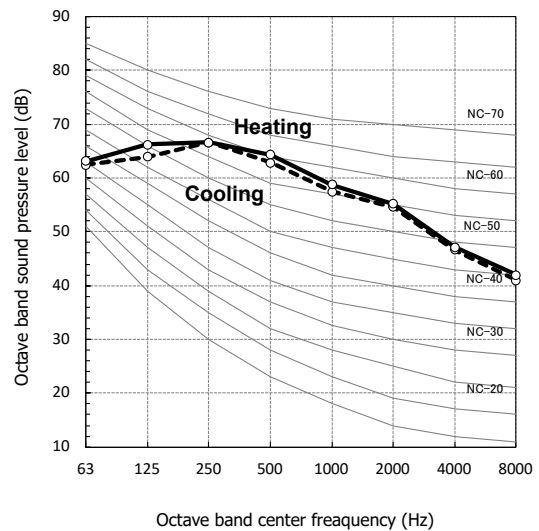



MMY-AP4416HT8P-E

Sound pressure Level (dB(A))	Cooling	Heating
	64.0	65.0

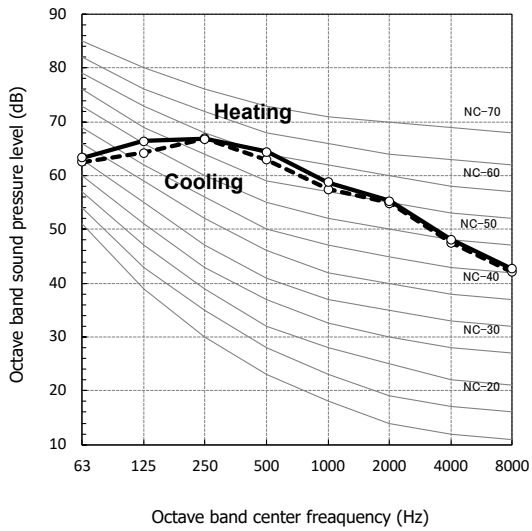

MMY-AP4616HT8P-E

Sound pressure Level (dB(A))	Cooling	Heating
	66.5	68.5

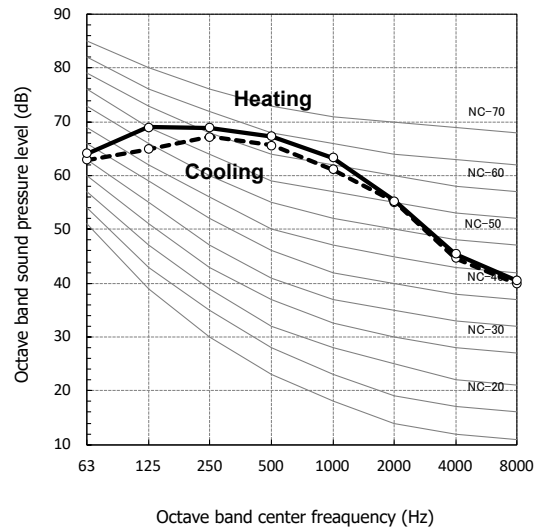

MMY-AP4816HT8P-E

Sound pressure Level (dB(A))	Cooling	Heating
	67.0	69.0

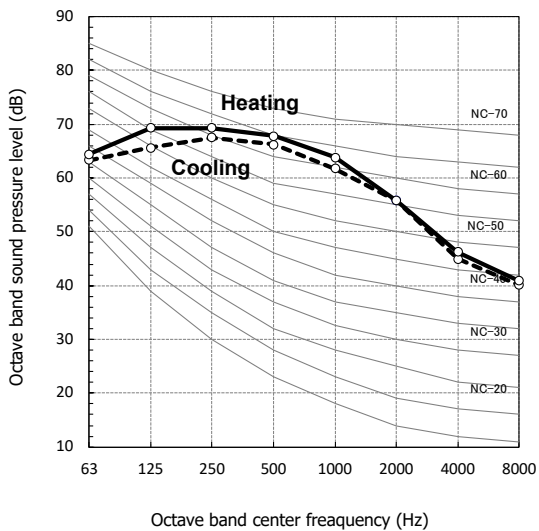

MMY-AP5016HT8P-E

Sound pressure Level (dB(A))	Cooling	Heating
	66.5	68.0

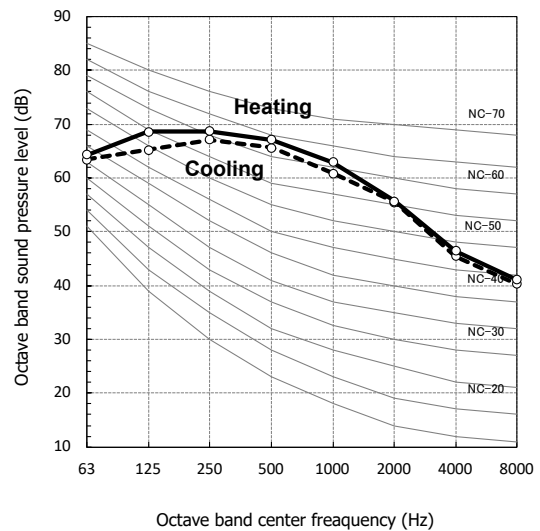



MMY-AP5216HT8P-E

Sound pressure Level (dB(A))	Cooling	Heating
	66.5	68.5

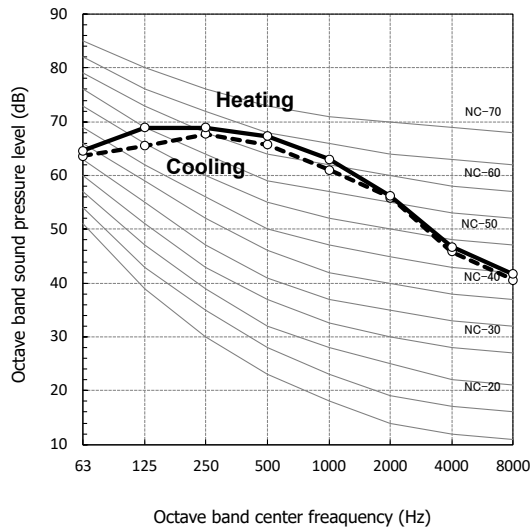

MMY-AP5416HT8P-E

Sound pressure Level (dB(A))	Cooling	Heating
	66.5	68.5

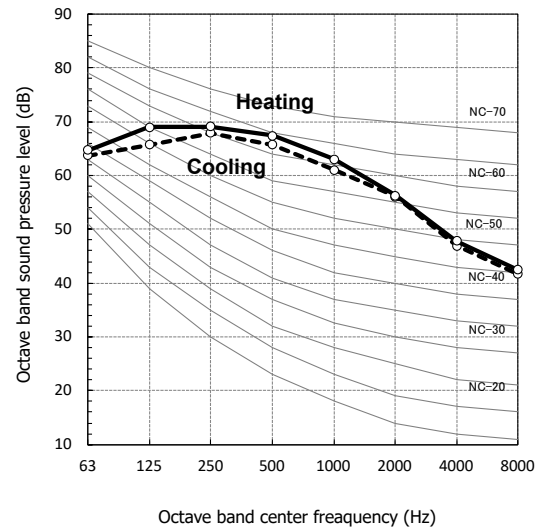

MMY-AP5616HT8P-E

Sound pressure Level (dB(A))	Cooling	Heating
	66.5	67.5

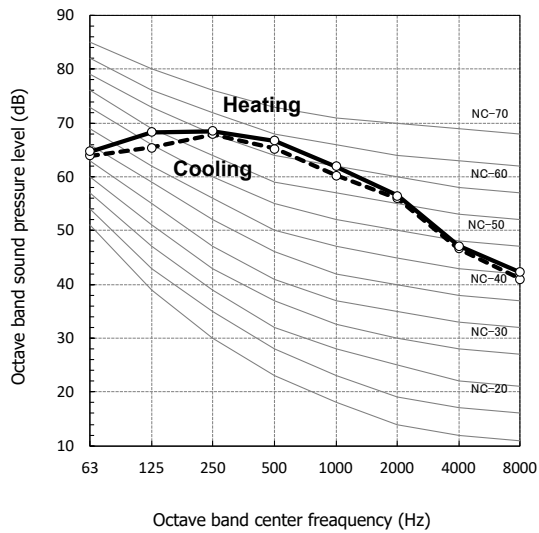

MMY-AP5816HT8P-E

Sound pressure Level (dB(A))	Cooling	Heating
	66.5	67.5

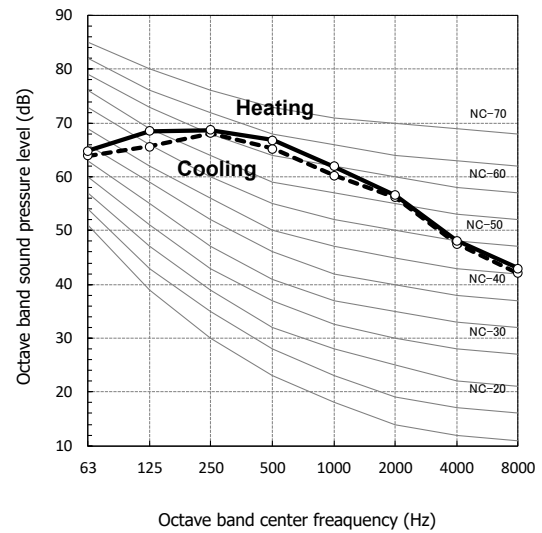



MMY-AP6016HT8P-E

Sound pressure Level (dB(A))	Cooling	Heating
	66.5	67.5

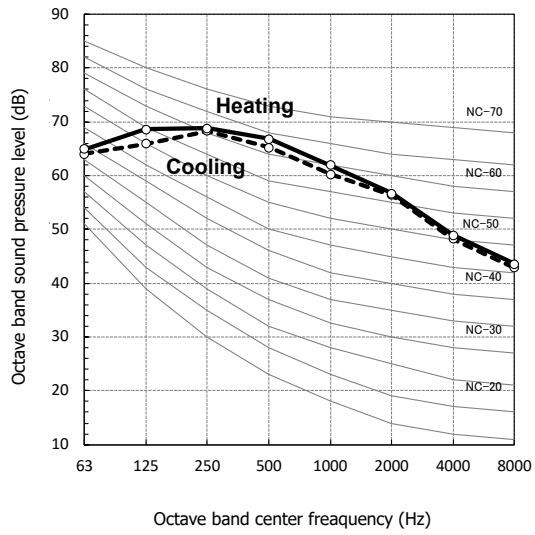



High efficiency model

MMY-AP2026HT8P-E

Sound pressure Level (dB(A))	Cooling	Heating
	60.0	61.0

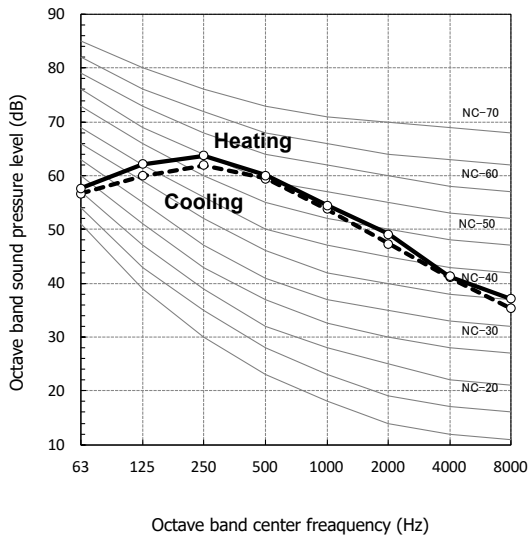

MMY-AP2226HT8P-E

Sound pressure Level (dB(A))	Cooling	Heating
	61.5	63.0

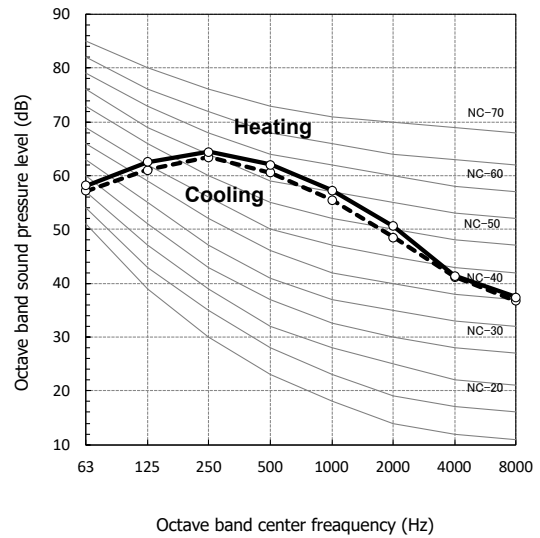

MMY-AP3626HT8P-E

Sound pressure Level (dB(A))	Cooling	Heating
	64.0	66.0

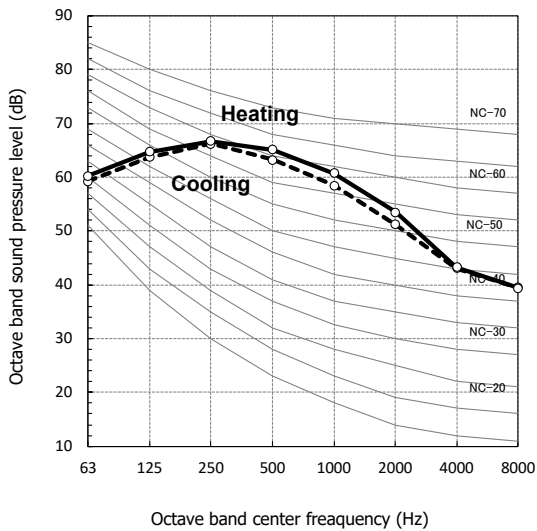

MMY-AP3826HT8P-E

Sound pressure Level (dB(A))	Cooling	Heating
	64.5	66.5

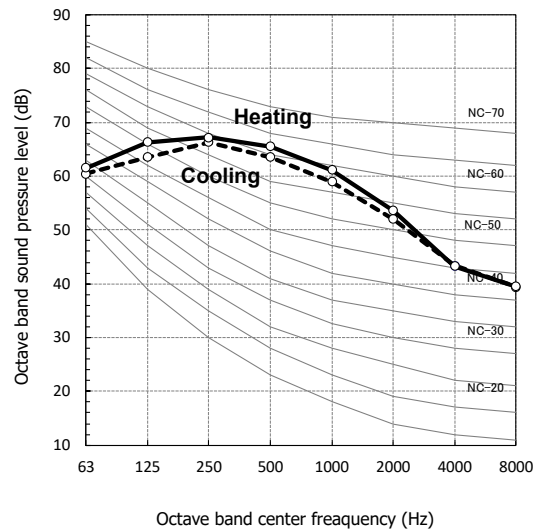



MMY-AP4026HT8P-E

Sound pressure Level (dB(A))	Cooling	Heating
	64.5	66.5

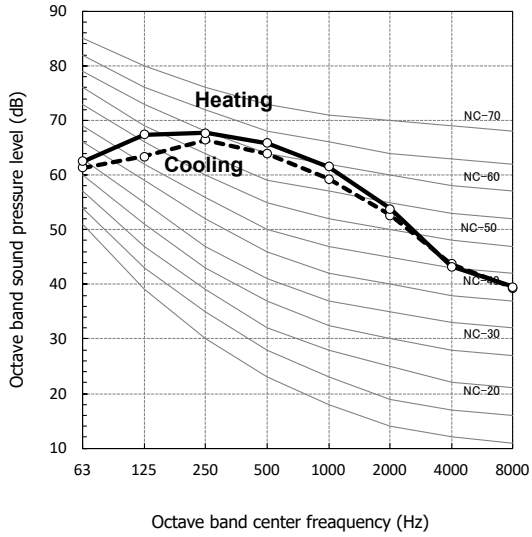

MMY-AP4226HT8P-E

Sound pressure Level (dB(A))	Cooling	Heating
	65.0	67.0

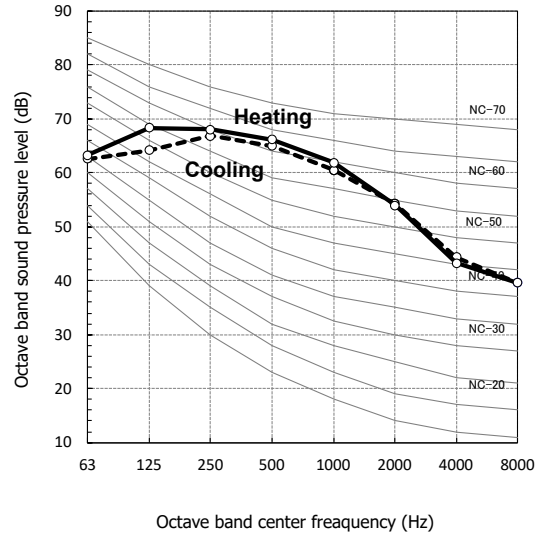

MMY-AP4426HT8P-E

Sound pressure Level (dB(A))	Cooling	Heating
	65.5	67.5

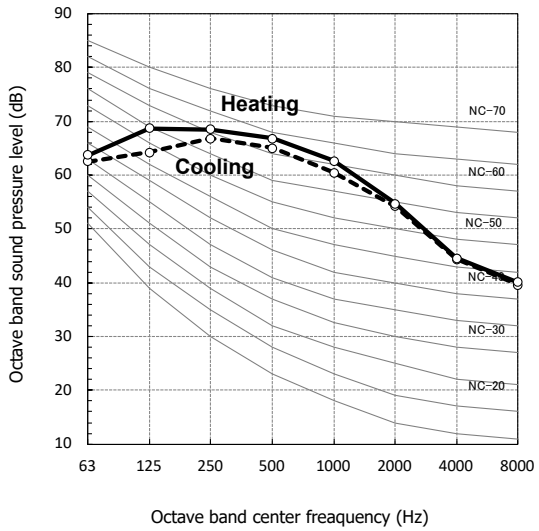

MMY-AP5426HT8P-E

Sound pressure Level (dB(A))	Cooling	Heating
	65.5	67.0

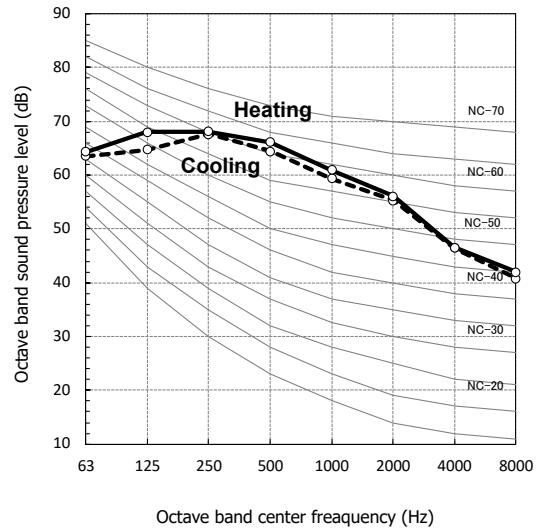

SMMS-e Engineering Data Book

Model name:

MMY-MAP_6HT8P-E

MMY-SAP_6HT8P-E

July, 2019 Full version