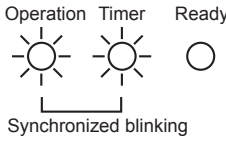
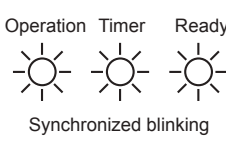
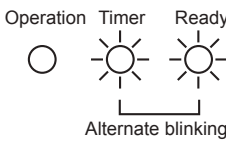

Light block	Check code	Cause of check code
	J03	Duplicated FS units
	J10	FS unit overflow trouble
	J11	FS unit temperature sensor(TCS) trouble
	F31	Outdoor EEPROM trouble

Other (indications not involving check code)

Light block	Check code	Cause of check code
	-	Test run in progress
	-	Setting incompatibility (automatic cooling/heating setting for model incapable of it and heating setting for cooling-only model)

8-4. Check Codes Displayed on Remote Controller and SHRM-e Outdoor Unit (7-Segment Display on I/F Board) and Locations to Be Checked

For other types of outdoor units, refer to their own service manuals.

Check code		Location of detection	Description	System status	Check code detection condition(s)	Check items (locations)
Main remote controller	Outdoor 7-segment display					
	Check code	Sub-code				
E01	-	-	Remote controller Indoor-remote controller communication trouble (detected at remote controller end)	Stop of corresponding unit	Communication between indoor P.C. board and remote controller is disrupted.	<ul style="list-style-type: none"> • Check remote controller inter-unit tie cable (A/B). • Check for broken wire or connector bad contact. • Check indoor power supply. • Check for defect in indoor P.C. board. • Check remote controller address settings (when two remote controllers are in use). • Check remote controller P.C. board.
E02	-	-	Remote controller Remote controller transmission trouble	Stop of corresponding unit	Signal cannot be transmitted from remote controller to indoor unit.	<ul style="list-style-type: none"> • Check internal transmission circuit of remote controller. --- Replace remote controller as necessary.
E03	-	-	Indoor unit Indoor-remote controller communication trouble (detected at indoor end)	Stop of corresponding unit	There is no communication from remote controller (including wireless) or network adaptor.	<ul style="list-style-type: none"> • Check remote controller and network adaptor wiring.
E04	-	-	Indoor unit Indoor-outdoor communication circuit trouble (detected at indoor end)	Stop of corresponding unit	Indoor unit is not receiving signal from outdoor unit.	<ul style="list-style-type: none"> • Check order in which power was turned on for indoor and outdoor units. • Check indoor address setting. • Check indoor-outdoor tie cable. • Check outdoor terminator resistor setting (SW30, Bit 2).
E04	E06	No. of indoor units from which signal is received normally	I/F Dropping out of indoor unit	All stop	<p>Condition 1 All indoor unit initially communicating normally fails to return signal for specified length of time.</p> <p>Condition 2 Outdoor I / F board SW09, Bit 4: OFF (Factory default)</p>	<ul style="list-style-type: none"> • Check power supply to indoor unit. (Is power turned on?) • Check connection of indoor-outdoor communication cable. • Check connection of communication connectors on indoor P.C. board. • Check connection of communication connectors on outdoor P.C. board. • Check for defect in indoor P.C. board. • Check for defect in outdoor P.C. board (I/F).
	-	-	Indoor unit Indoor-outdoor communication circuit trouble	Only specified indoor units stop	<p>Condition 1 Indoor unit initially communicating normally fails to return signal for specified length of time.</p>	<ul style="list-style-type: none"> • Check power supply to indoor unit. (Is power turned on?) • Check indoor-outdoor power-on sequence. • Check indoor address setting • Check wiring of Indoor-outdoor communication wires • Check outdoor terminator resistor setting (SW30, Bit 2).

Check code			Location of detection	Description	System status	Check code detection condition(s)	Check items (locations)
Main remote controller	Outdoor 7-segment display						
	Check code	Sub-code					
E04/E06	E06	No. of indoor units from which signal is received normally	Indoor unit	Indoor-outdoor communication circuit trouble (E04)	All stop	<p>Condition 1 One indoor unit or more initially communicating normally fails to return signal for specified length of time.</p> <p>Condition 2 Outdoor I / F board SW09, Bit 4: ON (To switch the check code detection condition.)</p> 	<ul style="list-style-type: none"> • Check power supply to indoor unit. (Is power turned on?) • Check indoor-outdoor power-on sequence. • Check indoor address setting • Check wiring of Indoor-outdoor communication wires • Check outdoor terminator resistor setting (SW30, Bit 2).
			I/F	Dropping out of indoor unit (E06)			
-	E07	-	I/F	Indoor-outdoor communication circuit trouble (detected at outdoor end)	All stop	Signal cannot be transmitted from outdoor to indoor units for 30 seconds continuously.	<ul style="list-style-type: none"> • Check outdoor terminator resistor setting (SW30, Bit 2). • Check connection of indoor-outdoor communication circuit.
E08	E08	Duplicated indoor address	Indoor unit I/F	Duplicated indoor address	All stop	More than one indoor unit are assigned same address.	<ul style="list-style-type: none"> • Check indoor addresses. • Check for any change made to remote controller connection (group/ individual) since indoor address setting.
E09	-	-	Remote controller	Duplicated master remote controller	Stop of corresponding unit	In two remote controller configuration (including wireless), both controllers are set up as master. (Header indoor unit is shut down with alarm, while follower indoor units continue operating.)	<ul style="list-style-type: none"> • Check remote controller settings. • Check remote controller P.C. boards.
E10	-	-	Indoor unit	Indoor inter-MCU communication trouble	Stop of corresponding unit	Communication cannot be established/maintained upon turning on of power or during communication.	<ul style="list-style-type: none"> • Check for trouble in indoor P.C. board.
E12	E12	01: Indoor-outdoor communication 02: Outdoor-outdoor communication	I/F	Automatic address starting trouble	All stop	<ul style="list-style-type: none"> • Indoor automatic address setting is started while automatic address setting for equipment in other refrigerant line is in progress. • Outdoor automatic address setting is started while automatic address setting for indoor units is in progress. 	<ul style="list-style-type: none"> • Perform automatic address setting again after disconnecting communication cable to that refrigerant line.

Check code			Location of detection	Description	System status	Check code detection condition(s)	Check items (locations)
Main remote controller	Outdoor 7-segment display						
	Check code	Sub-code					
E15	E15	-	I/F	Indoor unit not found during automatic address setting	All stop	Indoor unit cannot be detected after indoor automatic address setting is started.	<ul style="list-style-type: none"> • Check connection of indoor-outdoor communication line. • Check for trouble in indoor power supply system. • Check for noise from other devices. • Check for power failure. • Check for trouble in indoor P.C. board.
E16	E16	00: Overloading 01 -: No. of units connected	I/F	Too many indoor units connected	All stop	<ul style="list-style-type: none"> • Combined capacity of indoor units exceeds 135% of combined capacity of outdoor units. <p>Note: If this code comes up after backup setting for outdoor unit failure is performed, perform "No overloading detected" setting.</p> <p><"No overloading detected" setting method> Turn on SW09/Bit 2 on I/F P.C. board of outdoor header unit.</p> <ul style="list-style-type: none"> • More than 64 indoor units are connected. 	<ul style="list-style-type: none"> • Check capacities of indoor units connected. • Check combined HP capacities of indoor units. • Check HP capacity settings of outdoor units. • Check No. of indoor units connected. • Check for trouble in outdoor P.C. board (I/F).
E17	-	-	Indoor unit	Indoor unit(s) -FS unit(s) communication trouble	Stop of corresponding unit(s)	There is no communication from FS unit(s)	<ul style="list-style-type: none"> • Check order in which power was turned on. • Check indoor unit(s)-FS unit(s) cable

Check code			Location of detection	Description	System status	Check code detection condition(s)	Check items (locations)
Main remote controller	Outdoor 7-segment display						
	Check code	Sub-code					
E18	-	-	Indoor unit	Trouble in communication between indoor header and follower units	Stop of corresponding unit	Periodic communication between indoor header and follower units cannot be maintained.	<ul style="list-style-type: none"> • Check remote controller wiring. • Check indoor power supply wiring. • Check P.C. boards of indoor units.
E19	E19	00: No header unit 02: Two or more header units	I/F	Trouble in number of outdoor header units	All stop	<ul style="list-style-type: none"> • There are more than one outdoor header units in one line. • There is no outdoor header unit in one line. 	<ul style="list-style-type: none"> • Outdoor header unit is outdoor unit to which indoor-outdoor tie cable (U1,U2) is connected. • Check connection of indoor-outdoor communication line. • Check for defect in outdoor P.C. board (I/F).
E20	E20	01: Connection of outdoor unit from other line 02: Connection of indoor unit from other line	I/F	Connection to other line found during automatic address setting	All stop	Equipment from other line is found to have been connected when indoor automatic address setting is in progress.	Disconnect inter-line tie cable in accordance with automatic address setting method explained in "Address setting" section.
E23	E23	-	I/F	Outdoor-outdoor communication transmission trouble	All stop	Signal cannot be transmitted to other outdoor units for at least 30 seconds continuously.	<ul style="list-style-type: none"> • Check power supply to outdoor units. (Is power turned on?) • Check connection of tie cables between outdoor units for bad contact or broken wire. • Check communication connectors on outdoor P.C. boards. • Check for defect in outdoor P.C. board (I/F). • Check termination resistance setting for communication between outdoor units.
E25	E25	-	I/F	Duplicated follower outdoor address	All stop	There is duplication in outdoor addresses set manually.	Note: Do not set outdoor addresses manually.
E26	E26	Address of outdoor unit from which signal is not received normally	I/F	Signal lack of outdoor unit	All stop	Outdoor unit initially communicating normally fails to return signal for specified length of time.	<ul style="list-style-type: none"> • Backup setting is being used for outdoor units. • Check power supply to outdoor unit. (Is power turned on?) • Check connection of tie cables between outdoor units for bad contact or broken wire. • Check communication connectors on outdoor P.C. boards. • Check for trouble in outdoor P.C. board (I/F).
E28	E28	Detected outdoor unit No.	I/F	Outdoor follower unit trouble	All stop	Outdoor header unit receives check code from outdoor follower unit.	<ul style="list-style-type: none"> • Check check code displayed on outdoor follower unit. <p><Convenient functions> If SW04 is pressed and held for at least 1 second while [E28] is displayed on the 7-segment display of outdoor header unit, the fan of the outdoor unit that has been shut down due to a trouble comes on. If SW04 and SW05 are pressed simultaneously, the fans of normal outdoor units come on. To stop the fan or fans, press SW05 on its own.</p>

Check code			Location of detection	Description	System status	Check code detection condition(s)	Check items (locations)																																																																																
Main remote controller	Outdoor 7-segment display																																																																																						
	Check code	Sub-code																																																																																					
E31	E31	<table border="1"> <thead> <tr> <th colspan="2">A3-IPDU</th> <th colspan="2">Fan-IPDU</th> <th colspan="2">A3-IPDU</th> <th colspan="2">Fan-IPDU</th> </tr> <tr> <th>1</th> <th>2</th> <th>1</th> <th>2</th> <th>1</th> <th>2</th> <th>1</th> <th>2</th> </tr> </thead> <tbody> <tr> <td>01</td> <td>○</td> <td></td> <td></td> <td>10</td> <td></td> <td></td> <td>○</td> </tr> <tr> <td>02</td> <td>○</td> <td>○</td> <td></td> <td>11</td> <td>○</td> <td></td> <td>○</td> </tr> <tr> <td>03</td> <td>○</td> <td>○</td> <td>○</td> <td>12</td> <td></td> <td>○</td> <td>○</td> </tr> <tr> <td>08</td> <td></td> <td></td> <td>○</td> <td>13</td> <td>○</td> <td></td> <td>○</td> </tr> <tr> <td>09</td> <td>○</td> <td></td> <td>○</td> <td>18</td> <td></td> <td></td> <td>○</td> </tr> <tr> <td>0A</td> <td></td> <td>○</td> <td>○</td> <td>19</td> <td>○</td> <td></td> <td>○</td> </tr> <tr> <td>0B</td> <td>○</td> <td>○</td> <td>○</td> <td>1A</td> <td></td> <td>○</td> <td>○</td> </tr> <tr> <td></td> <td></td> <td></td> <td></td> <td>1B</td> <td>○</td> <td>○</td> <td>○</td> </tr> </tbody> </table> <p>Circle (O): troubled IPDU</p>	A3-IPDU		Fan-IPDU		A3-IPDU		Fan-IPDU		1	2	1	2	1	2	1	2	01	○			10			○	02	○	○		11	○		○	03	○	○	○	12		○	○	08			○	13	○		○	09	○		○	18			○	0A		○	○	19	○		○	0B	○	○	○	1A		○	○					1B	○	○	○	I/F	IPDU communication trouble	All stop	Communication is disrupted between IPDUs (P.C. boards) in inverter box.	<ul style="list-style-type: none"> Check wiring and connectors involved in communication between IPDU-I/F P.C. board for bad contact or broken wire. Check for trouble in outdoor P.C. board (I/F, A3-IPDU or Fan IPDU). Check for external noise.
		A3-IPDU		Fan-IPDU		A3-IPDU		Fan-IPDU																																																																															
1	2	1	2	1	2	1	2																																																																																
01	○			10			○																																																																																
02	○	○		11	○		○																																																																																
03	○	○	○	12		○	○																																																																																
08			○	13	○		○																																																																																
09	○		○	18			○																																																																																
0A		○	○	19	○		○																																																																																
0B	○	○	○	1A		○	○																																																																																
				1B	○	○	○																																																																																
		80		Communication trouble between MCU and Sub MCU	All stop	Communication between MCU and Sub MCU stopped.	<ul style="list-style-type: none"> Operation of power supply reset (OFF for 60 seconds or more) Outdoor I/F PC board trouble check 																																																																																
F01	-	-	Indoor unit	Indoor TCJ sensor trouble	Stop of corresponding unit	Sensor resistance is infinity or zero (open/short circuit).	<ul style="list-style-type: none"> Check connection of TCJ sensor connector and wiring. Check resistance characteristics of TCJ sensor. Check for trouble in indoor P.C. board. 																																																																																
F02	-	-	Indoor unit	Indoor TC2 sensor trouble	Stop of corresponding unit	Sensor resistance is infinity or zero (open/short circuit).	<ul style="list-style-type: none"> Check connection of TC2 sensor connector and wiring. Check resistance characteristics of TC2 sensor. Check for trouble in indoor P.C. board. 																																																																																
F03	-	-	Indoor unit	Indoor TC1 sensor trouble	Stop of corresponding unit	Sensor resistance is infinity or zero (open/short circuit).	<ul style="list-style-type: none"> Check connection of TC1 sensor connector and wiring. Check resistance characteristics of TC1 sensor. Check for trouble in indoor P.C. board. 																																																																																
F04	F04	-	I/F	TD1 sensor trouble	All stop	Sensor resistance is infinity or zero (open/short circuit).	<ul style="list-style-type: none"> Check connection of TD1 sensor connector. Check resistance characteristics of TD1 sensor. Check for trouble in outdoor P.C. board (I/F). 																																																																																
F05	F05	-	I/F	TD2 sensor trouble	All stop	Sensor resistance is infinity or zero (open/short circuit).	<ul style="list-style-type: none"> Check connection of TD2 sensor connector. Check resistance characteristics of TD2 sensor. Check for trouble in outdoor P.C. board (I/F). 																																																																																
F06	F06	01: TE1 sensor trouble 02: TE2 sensor trouble	I/F	TE1/TE2 sensor trouble	All stop	Sensor resistance is infinity or zero (open/short circuit).	<ul style="list-style-type: none"> Check connection of TE1/TE2 sensor connectors. Check resistance characteristics of TE1/TE2 sensors. Check for trouble in outdoor P.C. board (I/F). 																																																																																
F07	F07	01: TL1 sensor trouble	I/F	TL1 sensor trouble	All stop	Sensor resistance is infinity or zero (open/short circuit).	<ul style="list-style-type: none"> Check connection of TL1 sensor connector. Check resistance characteristics of TL1 sensor. Check for trouble in outdoor P.C. board (I/F). 																																																																																

Check code			Location of detection	Description	System status	Check code detection condition(s)	Check items (locations)
Main remote controller	Outdoor 7-segment display						
	Check code	Sub-code					
F08	F08	-	I/F	TO sensor trouble	All stop	Sensor resistance is infinity or zero (open/short circuit).	<ul style="list-style-type: none"> • Check connection of TO sensor connector. • Check resistance characteristics of TO sensor. • Check for trouble in outdoor P.C. board (I/F).
F10	-	-	Indoor unit	Indoor TA sensor trouble	Stop of corresponding unit	Sensor resistance is infinity or zero (open/short circuit).	<ul style="list-style-type: none"> • Check connection of TA sensor connector and wiring. • Check resistance characteristics of TA sensor. • Check for trouble in indoor P.C. board.
F11	-	-	Indoor unit	Indoor TF sensor trouble	Stop of corresponding unit	Sensor resistance is infinity or zero (open/short circuit).	<ul style="list-style-type: none"> • Check connection of TF sensor connector and wiring. • Check resistance characteristics of TF sensor. • Check for trouble in indoor P.C. board.
F12	F12	01: TS1 sensor trouble 02: TS2 sensor trouble	I/F	TS1/TS2 sensor trouble	All stop	Sensor resistance is infinity or zero (open/short circuit).	<ul style="list-style-type: none"> • Check connection of TS1/TS2 sensor connector • Check resistance characteristics of TS1/TS2 sensor. • Check for trouble
F13	F13	01: Compressor 1 side 02: Compressor 2 side	IPDU	TH sensor trouble	All stop	Sensor resistance is infinity or zero (open/short circuit).	<ul style="list-style-type: none"> • Trouble in IPM built-in temperature sensor → Replace A3-IPDU P.C. board.
F15	F15	-	I/F	Outdoor temperature sensor wiring trouble (TE1, TL1)	All stop	During compressor operation in HEAT mode, TL1 continuously provides temperature reading higher than indicated by TL1 by at least specified margin for 3 minutes or more.	<ul style="list-style-type: none"> • Check installation of TE1 and TL1 sensors. • Check resistance characteristics of TE1 and TL1 sensors. • Check for outdoor P.C. board (I/F) trouble.
F16	F16	-	I/F	Outdoor pressure sensor wiring trouble (PD, PS)	All stop	Readings of high-pressure PD sensor and low-pressure PS sensor are switched. Output voltages of both sensors are zero.	<ul style="list-style-type: none"> • Check connection of high-pressure PD sensor connector. • Check connection of low-pressure PS sensor connector. • Check for defect in pressure sensors PD and PS. • Check for trouble in outdoor P.C. board (I/F). • Check for deficiency in compressive output of compressor.
F17	-	-	Indoor unit	TOA sensor trouble	Stop of corresponding unit	Sensor resistance is infinity or zero (open/short circuit).	<ul style="list-style-type: none"> • Check connection of TOA sensor connector. • Check resistance characteristics of TOA sensor. • Check for trouble in outdoor I/F P.C. board.
F18	-	-	Indoor unit	TRA sensor trouble	Stop of corresponding unit	Sensor resistance is infinity or zero (open/short circuit).	<ul style="list-style-type: none"> • Check connection of TRA sensor connector. • Check resistance characteristics of TRA sensor. • Check for trouble in outdoor I/F P.C. board.
F23	F23	-	I/F	PS sensor trouble	All stop	Output voltage of PS sensor is zero.	<ul style="list-style-type: none"> • Check for connection trouble involving PS sensor and PD sensor connectors. • Check connection of PS sensor connector. • Check for defect in PS sensor. • Check for deficiency in compressive output of compressor. • Check for trouble in 4-way valve. • Check for trouble in outdoor P.C. board (I/F). • Check for trouble in SV4 circuit.
F24	F24	-	I/F	PD sensor trouble	All stop	Output voltage of PD sensor is zero (sensor open-circuited). Pd > 4.15MPa despite compressor having been turned off.	<ul style="list-style-type: none"> • Check connection of PD sensor connector. • Check for trouble in PD sensor. • Check for trouble in outdoor P.C. board (I/F).

Check code		Location of detection	Description	System status	Check code detection condition(s)	Check items (locations)	
Main remote controller	Outdoor 7-segment display						
	Check code	Sub-code					
F29	–	–	Indoor unit	Other indoor trouble	Stop of corresponding unit	Indoor P.C. board does not operate normally.	• Check for defect in indoor P.C. board (faulty EEPROM)
F31	F31	–	I/F	Outdoor EEPROM trouble	All stop *1	Outdoor P.C. board (I/F) does not operate normally.	• Check power supply voltage. • Check power supply noise. • Check for trouble in outdoor P.C. board (I/F).
H01	H01	01: Compressor 1 side 02: Compressor 2 side	IPDU	Compressor breakdown	All stop	Inverter current detection circuit detects overcurrent and shuts system down.	• Check power supply voltage. (AC380-415V ± 10%). • Check for trouble in compressor. • Check for possible cause of abnormal overloading. • Check for trouble in outdoor P.C. board (A3-IPDU).
H02	H02	01: Compressor 1 side 02: Compressor 2 side	IPDU	Compressor trouble (lockup) MG-CTT trouble	All stop	Overcurrent is detected several seconds after startup of inverter compressor.	• Check for trouble in compressor. • Check power supply voltage. (AC380-415V ± 10%). • Check compressor system wiring, particularly for open phase. • Check connection of connectors/terminals on A3-IPDU P.C. board. • Check conductivity of case heater. (Check for refrigerant problem inside compressor.) • Check for trouble in outdoor P.C. board (A3-IPDU). • Check outdoor MG-CTT.
H03	H03	01: Compressor 1 side 02: Compressor 2 side	IPDU	Current detection circuit trouble	All stop	Current flow of at least specified magnitude is detected despite inverter compressor having been shut turned off.	• Check current detection circuit wiring. • Check trouble in outdoor P.C. board (A3-IPDU).
H05	H05	–	I/F	TD1 sensor miswiring (incomplete insertion)	All stop	Discharge temperature of compressor 1 (TD1) does not increase despite compressor being in operation.	• Check installation of TD1 sensor. • Check connection of TD1 sensor connector and wiring. • Check resistance characteristics of TD1 sensor. • Check for trouble in outdoor P.C. board (I/F).
H06	H06	–	I/F	Activation of low-pressure protection	All stop	Low-pressure Ps sensor detects operating pressure lower than 0.02MPa.	• Check service valves to confirm full opening (both gas and liquid sides). • Check outdoor PMVs for clogging (PMV1). • Check for trouble in SV2 or SV4 circuits. • Check for trouble in low-pressure PS sensor. • Check indoor filter for clogging. • Check valve opening status of indoor PMV. • Check refrigerant piping for clogging. • Check operation of outdoor fan (during heating). • Check for insufficiency in refrigerant quantity.

MG-CTT: Magnet contactor

*1 Total shutdown in case of header unit
Continued operation in case of follower unit

Check code			Location of detection	Description	System status	Check code detection condition(s)	Check items (locations)
Main remote controller	Outdoor 7-segment display						
	Check code	Sub-code					
H07	H07	–	I/F	Low oil level protection	All stop	Operating compressor detects continuous state of low oil level for about 2 hours.	<p><All outdoor units in corresponding line to be checked></p> <ul style="list-style-type: none"> • Check balance pipe service valve to confirm full opening. • Check connection and installation of TK1, TK2, TK4, and TK5 sensors. • Check resistance characteristics of TK1, TK2, TK4, and TK5 sensors. • Check for gas or oil leak in same line. • Check for refrigerant problem inside compressor casing. • Check SV3A, SV3B, SV3C, SV3D valves for trouble. • Check oil return circuit of oil separator for clogging. • Check oil equalizing circuit for clogging.
H08	H08	01: TK1 sensor trouble 02: TK2 sensor trouble 04: TK4 sensor trouble 05: TK5 sensor trouble	I/F	Trouble in temperature sensor for oil level detection	All stop	Sensor resistance is infinity or zero (open/short circuit).	<ul style="list-style-type: none"> • Check connection of TK1 sensor connector. • Check resistance characteristics of TK1 sensor. • Check for trouble in outdoor P.C. board (I/F).
					All stop	Sensor resistance is infinity or zero (open/short circuit).	<ul style="list-style-type: none"> • Check connection of TK2 sensor connector. • Check resistance characteristics of TK2 sensor. • Check for trouble in outdoor P.C. board (I/F).
					All stop	Sensor resistance is infinity or zero (open/short circuit).	<ul style="list-style-type: none"> • Check connection of TK4 sensor connector. • Check resistance characteristics of TK4 sensor. • Check for trouble in outdoor P.C. board (I/F).
					All stop	Sensor resistance is infinity or zero (open/short circuit).	<ul style="list-style-type: none"> • Check connection of TK5 sensor connector. • Check resistance characteristics of TK5 sensor. • Check for trouble in outdoor P.C. board (I/F).
H15	H15	–	I/F	TD2 sensor miswiring (incomplete insertion)	All stop	Discharge temperature of (TD2) does not increase despite compressor 2 being in operation.	<ul style="list-style-type: none"> • Check installation of TD2 sensor. • Check connection of TD2 sensor connector and wiring. • Check resistance characteristics of TD2 sensor. • Check for trouble in outdoor P.C. board (I/F).

Main remote controller	Check code		Location of detection	Description	System status	Check code detection condition(s)	Check items (locations)
	Outdoor 7-segment display						
	Check code	Sub-code					
H16	H16	01: TK1 oil circuit trouble 02: TK2 oil circuit trouble 04: TK4 oil circuit trouble 05: TK5 oil circuit trouble	I/F	Oil level detection circuit trouble	All stop	No temperature change is detected by TK1 despite compressor 1 having been started.	<ul style="list-style-type: none"> • Check for disconnection of TK1 sensor. • Check resistance characteristics of TK1 sensor. • Check for connection trouble involving TK1, TK2, TK4, and TK5 sensors • Check for clogging in oil equalizing circuit capillary and faulty operation in check valve. • Check for refrigerant entrapment inside compressor.
						No temperature change is detected by TK2 despite compressor 2 having been started.	<ul style="list-style-type: none"> • Check for disconnection of TK2 sensor. • Check resistance characteristics of TK2 sensor. • Check for connection trouble involving TK1, TK2, TK4, and TK5 sensors • Check for clogging in oil equalizing circuit capillary and faulty operation in check valve. • Check for refrigerant entrapment inside compressor.
						No temperature change is detected by TK4 despite compressor having been started.	<ul style="list-style-type: none"> • Check for disconnection of TK4 sensor. • Check resistance characteristics of TK4 sensor. • Check for connection trouble involving TK1, TK2, TK4, and TK5 sensors • Check for clogging in oil equalizing circuit capillary and faulty operation in check valve. • Check for refrigerant entrapment inside compressor.
						No temperature change is detected by TK5 despite compressor having been started.	<ul style="list-style-type: none"> • Check for disconnection of TK5 sensor. • Check resistance characteristics of TK5 sensor. • Check for connection trouble involving TK1, TK2, TK4, and TK5 sensors • Check for clogging in oil equalizing circuit capillary and faulty operation in check valve. • Check for refrigerant entrapment inside compressor.
J03	-	-	Indoor unit	Duplication of FS units	Stop of corresponding unit(s)	More than one FS units have been set up in one refrigerant line.	<ul style="list-style-type: none"> • Check indoor unit(s)-FS unit(s) cable
J10	J10	Detected indoor address	Indoor unit	FS unit overflow trouble	All stop	<ul style="list-style-type: none"> • Float switch operates • Float switch circuit is open-circuited or disconnected at connector. 	<ul style="list-style-type: none"> • Check float switch connector • Check operation of drain pump. • Check drain pump circuit • Check drain pipe for clogging • Check for defect indoor PC board.
J11	-	-	Indoor unit	FS unit Temperature sensor(TCS) trouble	Stop of corresponding unit(s)	Sensor resistance is infinity or zero(open/short circuit)	<ul style="list-style-type: none"> • Check connection of TCS sensor connector • Check resistance characteristics of TCS sensor. • Check for defect FS unit PC board.
L02	L02	-	Indoor unit	Outdoor units model disagreement trouble	All stop	In case of different outdoor unit	<ul style="list-style-type: none"> • Check outdoor unit model.
L03	-	-	Indoor unit	Duplicated indoor header unit	Stop of corresponding unit	There are more than one header units in group.	<ul style="list-style-type: none"> • Check indoor addresses. • Check for any change made to remote controller connection (group/individual) since indoor address setting.
L04	L04	-	I/F	Duplicated outdoor line address	All stop	There is duplication in line address setting for outdoor units belonging to different refrigerant piping systems.	<ul style="list-style-type: none"> • Check line addresses.

Check code		Location of detection	Description	System status	Check code detection condition(s)	Check items (locations)	
Main remote controller	Outdoor 7-segment display						
	Check code						Sub-code
L05	-	-	I/F	Duplicated priority indoor unit (as displayed on priority indoor unit)	All stop	More than one indoor units have been set up as priority indoor unit.	• Check display on priority indoor unit.
L06	L06	No. of priority indoor units	I/F	Duplicated priority indoor unit (as displayed on indoor unit other than priority indoor unit)	All stop	More than one indoor units have been set up as priority indoor unit.	• Check displays on priority indoor unit and outdoor unit.
L07	-	-	Indoor unit	Connection of group control cable to stand-alone indoor unit	Stop of corresponding unit	There is at least one stand-alone indoor unit to which group control cable is connected.	• Check indoor addresses.
L08	L08	-	Indoor unit	Indoor group / addresses not set	Stop of corresponding unit	Address setting has not been performed for indoor units.	• Check indoor addresses. Note: This code is displayed when power is turned on for the first time after installation.
L09	-	-	Indoor unit	Indoor capacity not set	Stop of corresponding unit	Capacity setting has not been performed for indoor unit.	Set indoor capacity. (DN = 11)
L10	L10	-	I/F	Outdoor capacity not set	All stop	Jumper wire provided on P.C. board for servicing I/F P.C. board has not been removed as required for given model.	Check model setting of P.C. board for servicing outdoor I/F P.C. board.
L12	L12	01:FS unit(s) installation trouble	I/F	FS unit(s) outside the application setting	All stop	Set up other than multi port type and single port type (Long piping model) FS unit(s) to 44HP or more system	•Check outdoor unit model name •Check FS unit model name •Check restricted installation of FS unit
L17	L17	-	I/F	Incompatible combination of outdoor units	All stop	Old model outdoor unit (prior to 6 series) has been connected	• Check outdoor unit model
L18	L18	Detected indoor address	FS unit	Cooling/heating selection unit trouble	Stop of corresponding unit	Cooling/heating cycle trouble resulting from piping trouble is detected	• Check Cooling/Heating FS unit • Check set Cooling-only setting.
L20	-	-	Network adaptor Indoor unit	Duplicated central control address	All stop	There is duplication in central control address setting.	• Check central control addresses. • Check network adaptor P.C. board .
L23	L23	Clean converter setting	I/F	SW setting mistake	All stop	Outdoor P.C. board (I/F) does not operate normally.	• Check switch setting of Bit 3 and 4 of SW17 in outdoor P.C. board (I/F).
L24	L24	01:Duplication of FS units address 02:Indoor units operation mode priority setting	I/F	FS unit(s) setting trouble	All stop	•Address setting has not been performed for FS units •Priority setting has not been performed for indoor units	•Check FS units address •Check indoor units operation mode priority setting •Check outdoor unit 7 segment monitor
L28	L28	-	I/F	Too many outdoor units connected	All stop	There are more than three outdoor units.	• Check No. of outdoor units connected (Only up to 3 units per system allowed). • Check communication lines between outdoor units. • Check for defect in outdoor P.C. board (I/F).

Check code		Location of detection	Description	System status	Check code detection condition(s)	Check items (locations)																																																																																										
Main remote controller	Outdoor 7-segment display																																																																																															
	Check code																																																																																															
L29	L29	<table border="1"> <thead> <tr> <th rowspan="2"></th> <th colspan="2">A3-IPDU</th> <th colspan="2">Fan-IPDU</th> <th colspan="2">A3-IPDU</th> <th colspan="2">Fan-IPDU</th> </tr> <tr> <th>1</th> <th>2</th> <th>1</th> <th>2</th> <th>1</th> <th>2</th> <th>1</th> <th>2</th> </tr> </thead> <tbody> <tr> <td>01</td> <td>○</td> <td></td> <td></td> <td></td> <td>10</td> <td></td> <td></td> <td></td> </tr> <tr> <td>02</td> <td></td> <td>○</td> <td></td> <td></td> <td>11</td> <td>○</td> <td></td> <td>○</td> </tr> <tr> <td>03</td> <td>○</td> <td>○</td> <td></td> <td></td> <td>12</td> <td></td> <td>○</td> <td>○</td> </tr> <tr> <td>08</td> <td></td> <td></td> <td>○</td> <td></td> <td>13</td> <td>○</td> <td>○</td> <td>○</td> </tr> <tr> <td>09</td> <td>○</td> <td></td> <td>○</td> <td></td> <td>18</td> <td></td> <td></td> <td>○</td> </tr> <tr> <td>0A</td> <td></td> <td>○</td> <td>○</td> <td></td> <td>19</td> <td>○</td> <td></td> <td>○</td> </tr> <tr> <td>0E</td> <td>○</td> <td>○</td> <td>○</td> <td></td> <td>1A</td> <td></td> <td>○</td> <td>○</td> </tr> <tr> <td></td> <td></td> <td></td> <td></td> <td></td> <td>1B</td> <td>○</td> <td>○</td> <td>○</td> </tr> </tbody> </table> <p>Circle (O): Troubled IPDU</p>		A3-IPDU		Fan-IPDU		A3-IPDU		Fan-IPDU		1	2	1	2	1	2	1	2	01	○				10				02		○			11	○		○	03	○	○			12		○	○	08			○		13	○	○	○	09	○		○		18			○	0A		○	○		19	○		○	0E	○	○	○		1A		○	○						1B	○	○	○	I/F	Trouble in No. of IPDUs	All stop	Insufficient number of IPDUs are detected when power is turned on.	<ul style="list-style-type: none"> Check model setting of P.C. board for servicing outdoor I/F P.C. board. Check connection of UART communication connector. Check A3-IPDU, fan IPDU, and I/F P.C. board for trouble.
				A3-IPDU		Fan-IPDU		A3-IPDU		Fan-IPDU																																																																																						
1	2		1	2	1	2	1	2																																																																																								
01	○				10																																																																																											
02		○			11	○		○																																																																																								
03	○	○			12		○	○																																																																																								
08			○		13	○	○	○																																																																																								
09	○		○		18			○																																																																																								
0A		○	○		19	○		○																																																																																								
0E	○	○	○		1A		○	○																																																																																								
					1B	○	○	○																																																																																								
L30	L30	Detected indoor address	Indoor unit	External interlock of indoor unit	Stop of corresponding unit	<ul style="list-style-type: none"> Signal is present at external trouble input terminal (CN80) for 1 minute. 	<p>When external device is connected to CN80 connector:</p> <ol style="list-style-type: none"> Check for trouble in external device. Check for trouble in indoor P.C. board. <p>When external device is not connected to CN80 connector:</p> <ol style="list-style-type: none"> Check for trouble in indoor P.C. board. 																																																																																									
-	L31	-	I/F	Extended IC trouble	Continued operation	There is part failure in P.C. board (I/F).	Check outdoor P.C. board (I/F).																																																																																									
P01	-	-	Indoor unit	Indoor fan motor trouble	Stop of corresponding unit		<ul style="list-style-type: none"> Check the lock of fan motor (AC fan). Check wiring. 																																																																																									
P03	P03	-	I/F	Discharge temperature TD1 trouble	All stop	Discharge temperature (TD1) exceeds 115°C.	<ul style="list-style-type: none"> Check outdoor service valves (gas side, liquid side) to confirm full opening. Check outdoor PMVs (PMV1,4) for clogging. Check resistance characteristics of TD1 sensor. Check for insufficiency in refrigerant quantity. Check for defect in 4-way valve. Check for leakage of SV4 circuit. Check SV4 circuit (wiring or installation trouble in SV41 or SV42). 																																																																																									

		Check code		Location of detection	Description	System status	Check code detection condition(s)	Check items (locations)
Main remote controller	Outdoor 7-segment display							
	Check code	Sub-code						
P04	P04	01: Compressor 1 side 02: Compressor 2 side	IPDU	Activation of high-pressure SW	All stop	High-pressure SW is activated.	<ul style="list-style-type: none"> • Check connection of high-pressure SW connector. • Check for trouble in PD pressure sensor. • Check outdoor service valves (gas side, liquid side) to confirm full opening. • Check for trouble in outdoor fan. • Check for trouble in outdoor fan motor. • Check outdoor PMVs (PMV1, 4) for clogging. • Check indoor/outdoor heat exchangers for clogging. • Check for short-circuiting of outdoor suction/discharge air flows. • Check SV2 circuit for clogging. • Check for trouble in outdoor P.C. board (I/F). • Check for trouble in indoor fan system (possible cause of air flow reduction). • Check opening status of indoor PMV. • Check indoor-outdoor communication line for wiring trouble. • Check for faulty operation of check valve in discharge pipe convergent section. • Check gas balancing SV4 valve circuit. • Check SV5 valve circuit. • Check for refrigerant overcharging. 	
P05	P05	00: 01: Compressor 1 side 02: Compressor 2 side	I/F	Detection of open phase/phase sequence Inverter DC voltage (Vdc) trouble (compressor) MG-CTT trouble	All stop	<ul style="list-style-type: none"> • Open phase is detected when power is turned on. • Inverter DC voltage is too high (overvoltage) or too low (undervoltage). 	<ul style="list-style-type: none"> • Check for trouble in outdoor P.C. board (I/F). • Check wiring of outdoor power supply. 	
P07	P07	01: Compressor 1 side 02: Compressor 2 side	IPDU I/F	Heat sink overheating trouble	All stop	Temperature sensor built into IPM (TH) is overheated.	<ul style="list-style-type: none"> • Check power supply voltage. • Check outdoor fan system trouble. • Check heat sink cooling duct for clogging. • Check IPM and heat sink for thermal performance for faulty installation. (e.g. mounting screws and thermal conductivity) • Check for trouble in A3-IPDU. (faulty IPM built-in temperature sensor (TH)) 	
P10	P10	Detected indoor address	Indoor unit	Indoor overflow trouble	All stop	<ul style="list-style-type: none"> • Float switch operates. • Float switch circuit is open-circuited or disconnected at connector. 	<ul style="list-style-type: none"> • Check float switch connector. • Check operation of drain pump. • Check drain pump circuit. • Check drain pipe for clogging. • Check for trouble in indoor P.C. board. 	
P12	-	-	Indoor unit	Indoor fan motor trouble	Stop of corresponding unit	<ul style="list-style-type: none"> • Motor speed measurements continuously deviate from target value. • Overcurrent protection is activated. 	<ul style="list-style-type: none"> • Check connection of fan connector and wiring. • Check for trouble in fan motor. • Check for trouble in indoor P.C. board. • Check impact of outside air treatment (OA). 	

MG-CTT: Magnet contactor

Check code			Location of detection	Description	System status	Check code detection condition(s)	Check items (locations)
Main remote controller	Outdoor 7-segment display						
	Check code	Sub-code					
P13	P13	-	I/F	Outdoor liquid backflow detection trouble	All stop	<p><During cooling operation> When system is in cooling operation, high pressure is detected in follower unit that has been turned off.</p> <p><During heating operation> When system is in heating operation, outdoor PMV 1 continuously registers opening of 300p or less while under superheat control.</p>	<ul style="list-style-type: none"> • Check full-close operation of outdoor PMV (1, 4). • Check for trouble in PD or PS sensor. • Check gas balancing circuit (SV2) for clogging. • Check balance pipe. • Check SV3B circuit for clogging. • Check trouble in outdoor P.C. board (I/F). • Check capillary of oil separator oil return circuit for clogging. • Check for leakage of check valve in discharge pipe convergent section.
P15	P15	01: TS condition	I/F	Gas leakdetection (TS1 condition)	All stop	Protective shutdown due to sustained suction temperature at or above judgment criterion for at least 10 minutes is repeated four times or more. <TS trouble judgment criterion> In cooling operation: 60°C In heating operation: 40°C	<ul style="list-style-type: none"> • Check for insufficiency in refrigerant quantity. • Check outdoor service valves (gas side, liquid side) to confirm full opening. • Check PMVs (PMV1, 4) for clogging. • Check resistance characteristics of TS1 sensor. • Check for trouble in 4-way valve. • Check SV4 circuit for leakage
		02: TD condition	I/F	Gas leak detection (TD condition)	All stop	Protective shutdown due to sustained discharge temperature (TD1 or TD2) at or above 108 °C for at least 10 minutes is repeated four times or more.	<ul style="list-style-type: none"> • Check for insufficiency in refrigerant quantity. • Check PMVs (PMV 1, 4) for clogging. • Check resistance characteristics of TD1 and TD2 sensors. • Check indoor filter for clogging. • Check piping for clogging. • Check SV4 circuit (for leakage or coil installation trouble).
P17	P17	-	I/F	Discharge temperature TD2 trouble	All stop	Discharge temperature (TD2) exceeds 115°C.	<ul style="list-style-type: none"> • Check outdoor service valves (gas side, liquid side) to confirm full opening. • Check outdoor PMVs (PMV1, 4) for clogging. • Check resistance characteristics of TD2 sensor. • Check for trouble in 4-way valve. • Check SV4 circuit for leakage. • Check SV4 circuit (for wiring or installation trouble involving SV41 and SV42).

Check code			Location of detection	Description	System status	Check code detection condition(s)	Check items (locations)
Main remote controller	Outdoor 7-segment display						
	Check code	Sub-code					
P19	P19	Detected outdoor unit No.	I/F	4-way valve reversing trouble	All stop	Abnormal refrigerating cycle data is collected during heating operation.	<ul style="list-style-type: none"> • Check for trouble in main body of 4-way valve. • Check for coil trouble in 4-way valve and loose connection of its connector. • Check resistance characteristics of TS1 and TE1, TE2 sensors. • Check output voltage characteristics of P and Ps pressure sensors. • Check for wiring trouble involving TE1 and TL1 sensors.
P20	P20	-	I/F	Activation of high-pressure protection	All stop	<p><During cooling operation> PD sensor detects pressure equal to or greater than 3.85 MPa.</p> <p><During heating operation> PD sensor detects pressure equal to or greater than 3.6 MPa.</p>	<ul style="list-style-type: none"> • Check for trouble in PD pressure sensor. • Check service valves (gas side, liquid side) to confirm full opening. • Check for trouble in outdoor fan. • Check for trouble in outdoor fan motor. • Check outdoor PMV (PMV1, 4) for clogging. • Check indoor/outdoor heat exchangers for clogging. • Check for short-circuiting of outdoor suction/discharge air flows. • Check SV2 circuit for clogging. • Check for trouble in outdoor P.C. board (I/F). • Check for trouble in indoor fan system (possible cause of air flow reduction). • Check opening status of indoor PMV. • Check indoor-outdoor communication line for wiring trouble. • Check for trouble operation of check valve in discharge pipe convergent section. • Check gas balancing SV4 valve circuit. • Check SV5 valve circuit. • Check for refrigerant overcharging.

Check code		Location of detection	Description	System status	Check code detection condition(s)	Check items (locations)	
Main remote controller	Outdoor 7-segment display						
	Check code						Sub-code
P22	P22	#0:Element short circuit	IPDU Outdoor fan IPDU trouble *Put in Fan IPDU No. in [#] mark	All stop	(Sub code: #0) Fan IPDU over current protection circuit Flow of current equal to or greater than the specified value is detected during startup of the fan.	<ul style="list-style-type: none"> • Check fan motor. • Check for trouble in fan IPDU P.C. board 	
		#1:Position detection circuit trouble			(Sub code: #1) Fan IPDU position detection circuit Position detection is not going on normally.	<ul style="list-style-type: none"> • Check fan motor. • Check connection of fan motor connector. • Check for trouble in fan IPDU P.C. board. 	
		#3:Motor lock trouble			(Sub code: #3) Gusty wind, an obstruction, or another external factor Speed estimation is not going on normally.	<ul style="list-style-type: none"> • Check fan motor. • Check for trouble in fan IPDU P.C. board 	
		#4:Motor current trouble			(Sub code: #4) Fan IPDU over current protection circuit Flow of current equal to or greater than the specified value is detected during operation of the fan.	<ul style="list-style-type: none"> • Check fan motor. • Check connection of fan motor connector. • Check for trouble in fan IPDU P.C. board. 	
		#C:TH sensor temperature trouble			(Sub code: #C) Higher temperature than the specified value is detected during operation of the fan.	<ul style="list-style-type: none"> • Check fan motor. • Check for trouble in fan IPDU P.C. board 	
		#D:TH sensor short circuit/release trouble			(Sub code: #D) The resistance value of the sensor is infinite or zero (open or short circuit).	<ul style="list-style-type: none"> • Check for trouble in fan IPDU P.C. board. 	
		#E:Vdc voltage trouble			(Sub code: #E) Fan IPDU DC voltage protection circuit The DC voltage higher or lower than the specified value is detected.	<ul style="list-style-type: none"> • Check power voltage of the main power supply. • Check for trouble in fan IPDU P.C. board. • Check connection of fan IPDU P.C. board. 	
P26	P26	01: Compressor 1 side 02: Compressor 2 side	IPDU IPM short-circuit protection trouble	All stop	Overcurrent is momentarily detected during startup of compressor.	<ul style="list-style-type: none"> • Check connector connection and wiring on A3-IPDU P.C. board. • Check for trouble in compressor (layer short-circuit). • Check for trouble in outdoor P.C. board (A3-IPDU). 	
P29	P29	01: Compressor 1 side 02: Compressor 2 side	IPDU Compressor position detection circuit trouble	All stop	Position detection is not going on normally.	<ul style="list-style-type: none"> • Check wiring and connector connection. • Check for compressor layer short-circuit. • Check for trouble in A3-IPDU P.C. board. 	
P31	-	-	Indoor unit Other indoor trouble (group follower unit trouble)	Stop of corresponding unit	There is trouble in other indoor unit in group, resulting in detection of E07/L07/L03/L08.	<ul style="list-style-type: none"> • Check indoor P.C. board. 	

Check codes Detected by TCC-LINK Central Control Device

Check code		Location of detection	Description	System status	Check code detection condition(s)	Check items (locations)	
Main remote controller	Outdoor 7-segment display						
Sub-code							
C05	–	TCC-LINK	TCC-LINK central control device transmission trouble	Continued operation	Central control device is unable to transmit signal.	<ul style="list-style-type: none"> • Check for trouble in central control device. • Check for trouble in central control communication line. • Check termination resistance setting. 	
C06	–		TCC-LINK central control device reception trouble	Continued operation	Central control device is unable to receive signal.	<ul style="list-style-type: none"> • Check for trouble in central control device. • Check for trouble in central control communication line. • Check terminator resistor setting. • Check power supply for devices at other end of central control communication line. • Check trouble in P.C. boards of devices at other end of central control communication line. 	
C12	–	General-purpose device I/F	Batch alarm for general-purpose device control interface	Continued operation	Trouble signal is input to control interface for general-purpose devices.	<ul style="list-style-type: none"> • Check trouble input. 	
P30	Differs according to nature of alarm-causing trouble		TCC-LINK	Group control follower unit trouble	Continued operation	Trouble occurs in follower unit under group control. ([P30] is displayed on central control remote controller.)	<ul style="list-style-type: none"> • Check check code of unit that has generated alarm.
	(L20 displayed.)			Duplicated central control address	Continued operation	There is duplication in central control addresses.	<ul style="list-style-type: none"> • Check address settings.

▼ Points to Note When Servicing Compressor

(1) When checking the outputs of inverters, remove the wiring from all the compressors.

▼ How to Check Inverter Output

(1) Turn off the power supply.

(2) Remove compressor leads from the IPDU P.C. board (A3-IPDU). (Be sure to remove all the leads.)

(3) Turn on the power supply and start cooling or heating operation.

Be careful not to make simultaneous contact with two or more faston connectors for compressor leads or a faston connector and some other object (e.g. the unit cabinet).

(4) Check the output voltage across each pair of inverter-side (CN201, 202, 203).

If the result is unsatisfactory according to the judgment criteria given in the table below, replace the IPDU P.C. board.

No.	Measured leads	Criterion
1	Red-White	380~580V
2	White-Black	380~580V
3	Black-Red	380~580V

* When connecting the compressor leads back to the compressor terminals after checking the output, check the faston connectors thoroughly to ensure that they are not crooked. If there is any loose connector, tighten it with a pair of pliers, etc. before connecting the lead.

▼ How to Check Resistance of Compressor Winding

(1) Turn off the power supply.

(2) Remove compressor leads from the compressors.

(3) With each compressor, check the phase-to-phase winding resistances and winding-to-outdoor cabinet resistance using a multimeter.

- Earth fault?
→ It is normal if the winding-to-outdoor cabinet resistance is 10M Ω or more.
- Inter-winding short circuit?
→ It is normal if the phase-to-phase resistances are in the 0.1-1.0 Ω range. (Use a digital multimeter.)

▼ How to Check Outdoor Fan Motor

(1) Turn off the power supply.

(2) Remove fan motor leads from the IPDU P.C. board for the outdoor fan (CN301-CN303).

(3) Rotate the fan by hand. If the fan does not turn, the fan motor is faulty (locked up). Replace the fan motor.

If the fan turns, measure the phase-to-phase winding resistances using a multimeter. It is normal if the measurements are in the 8.1-9.9 Ω range. (Use a digital multimeter.)

8-5. Diagnosis procedure for each check code

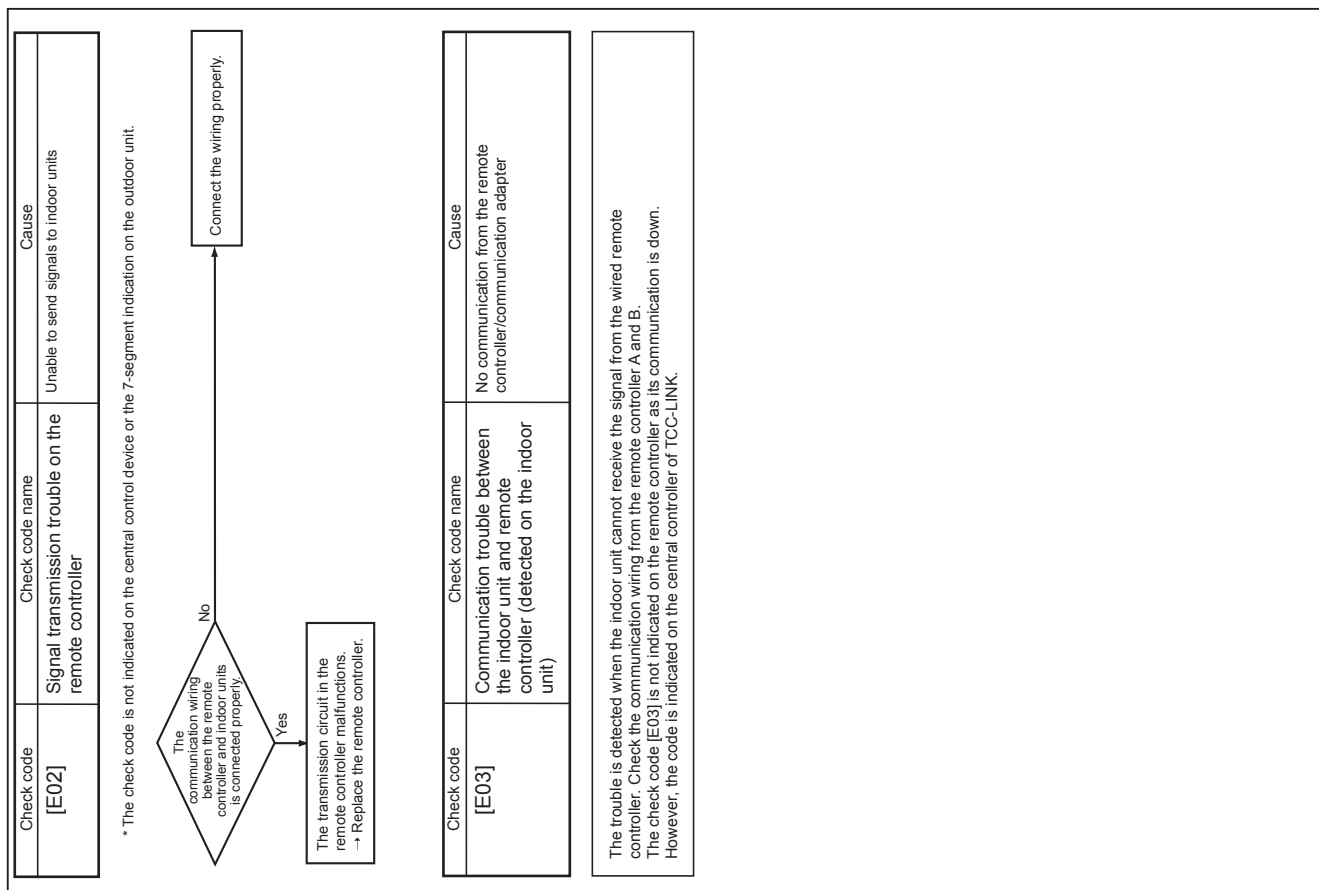
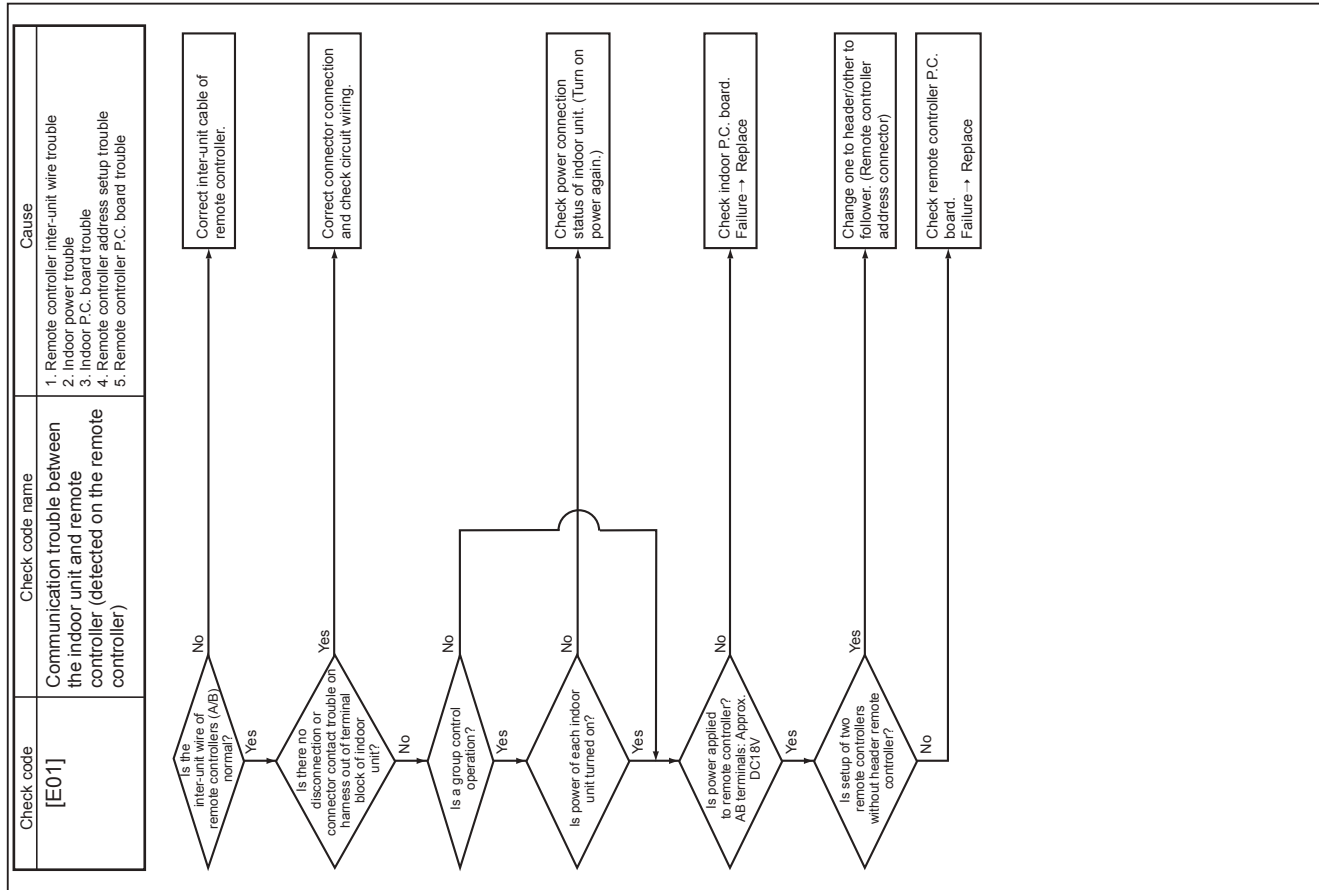

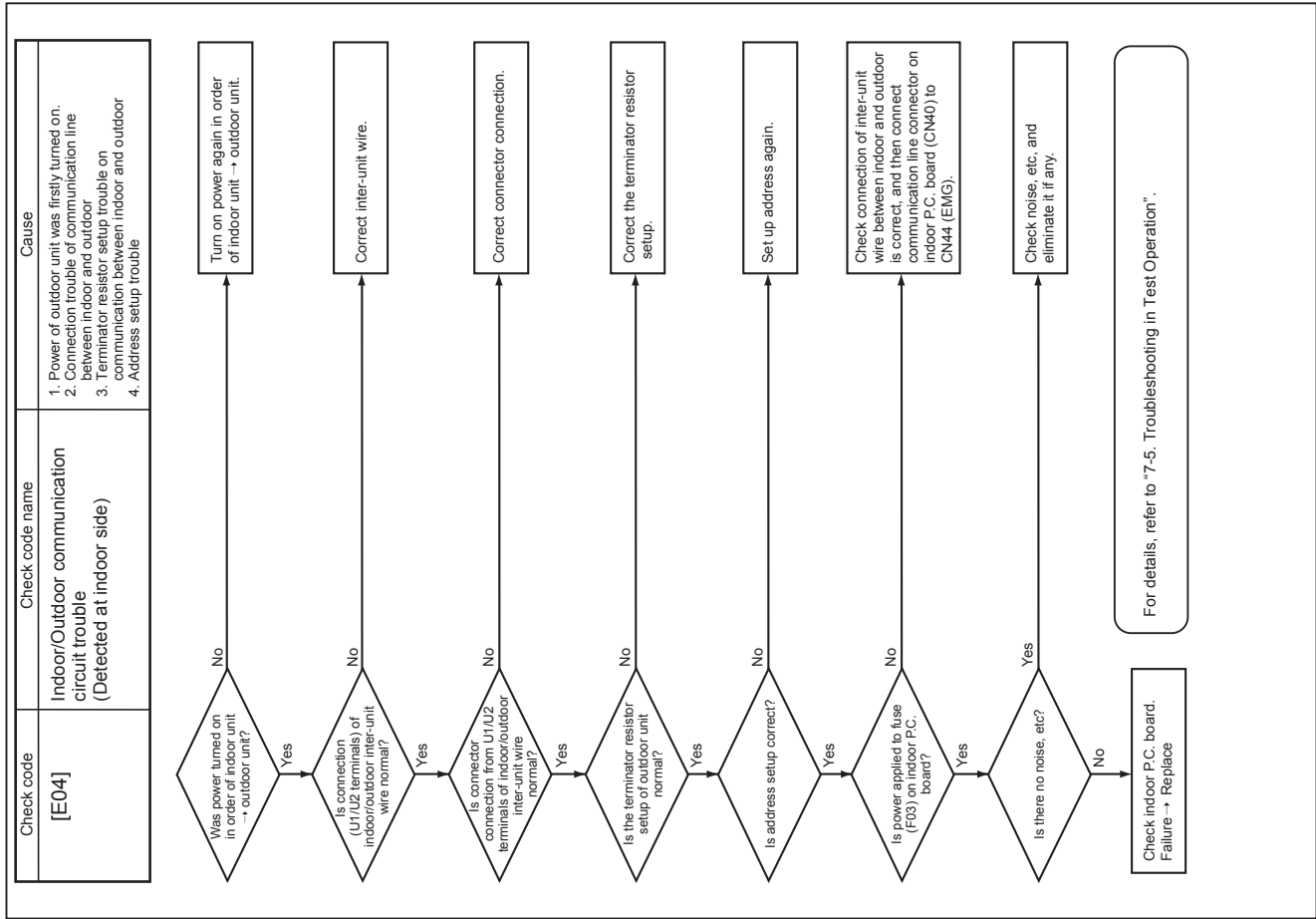
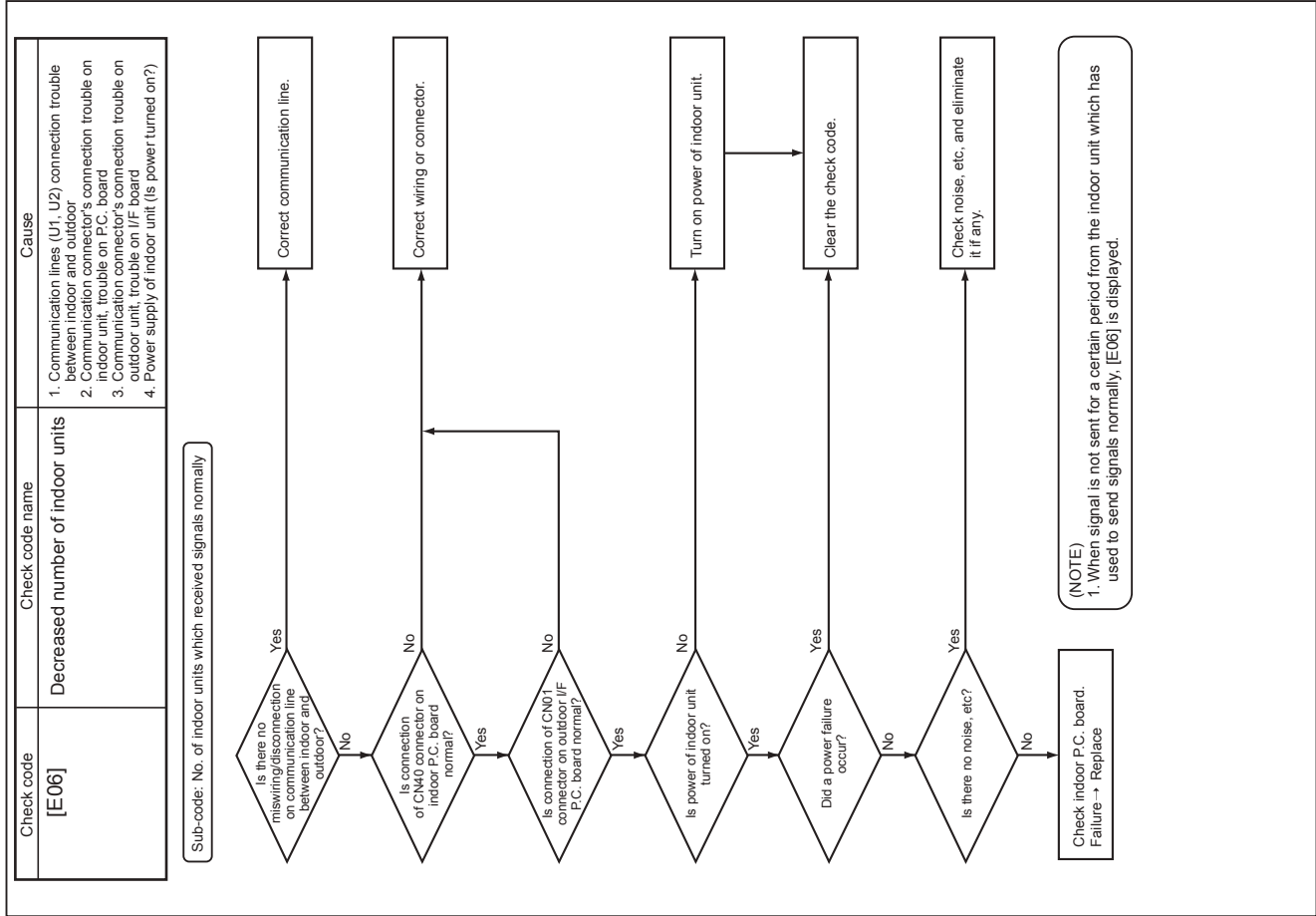

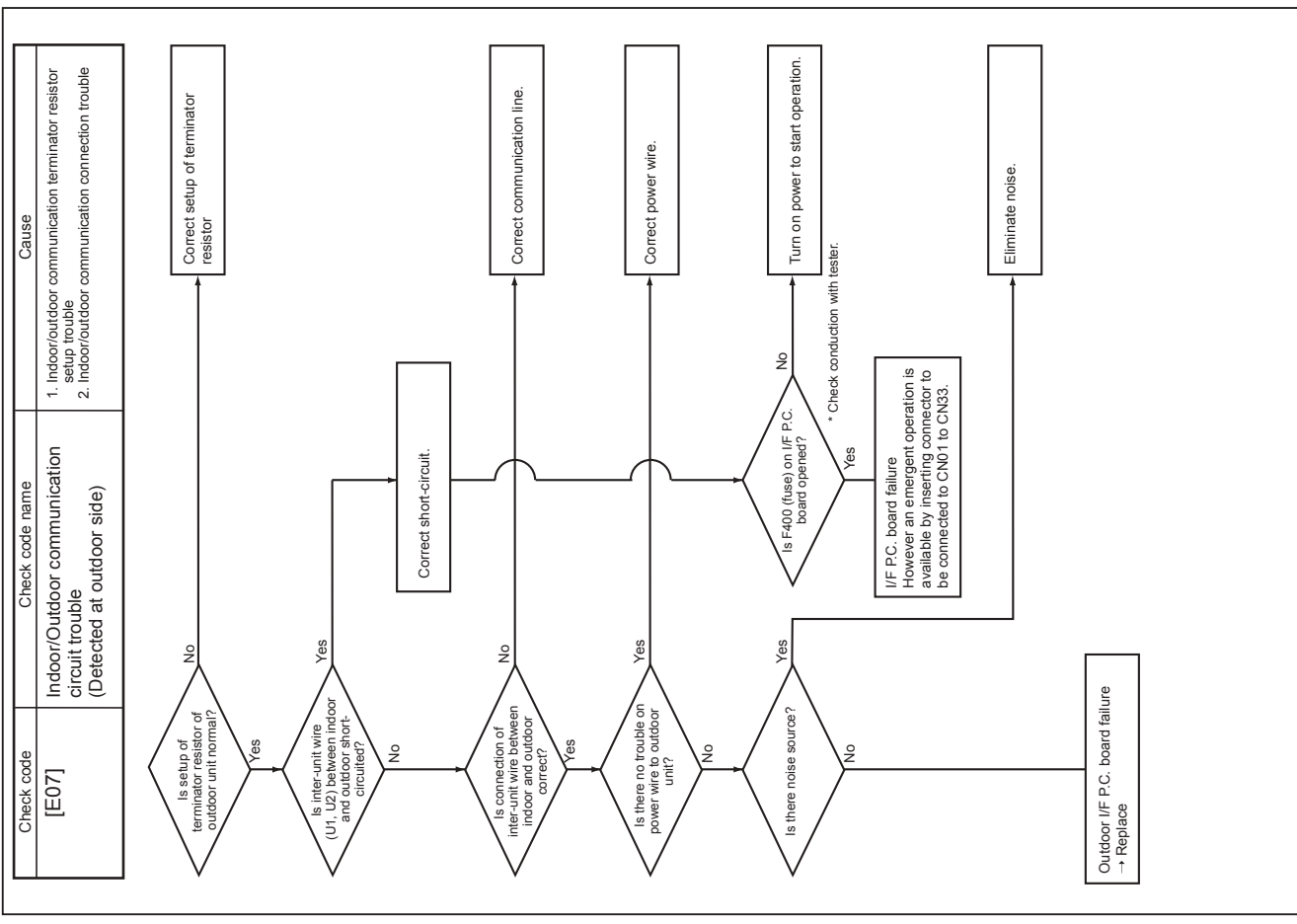
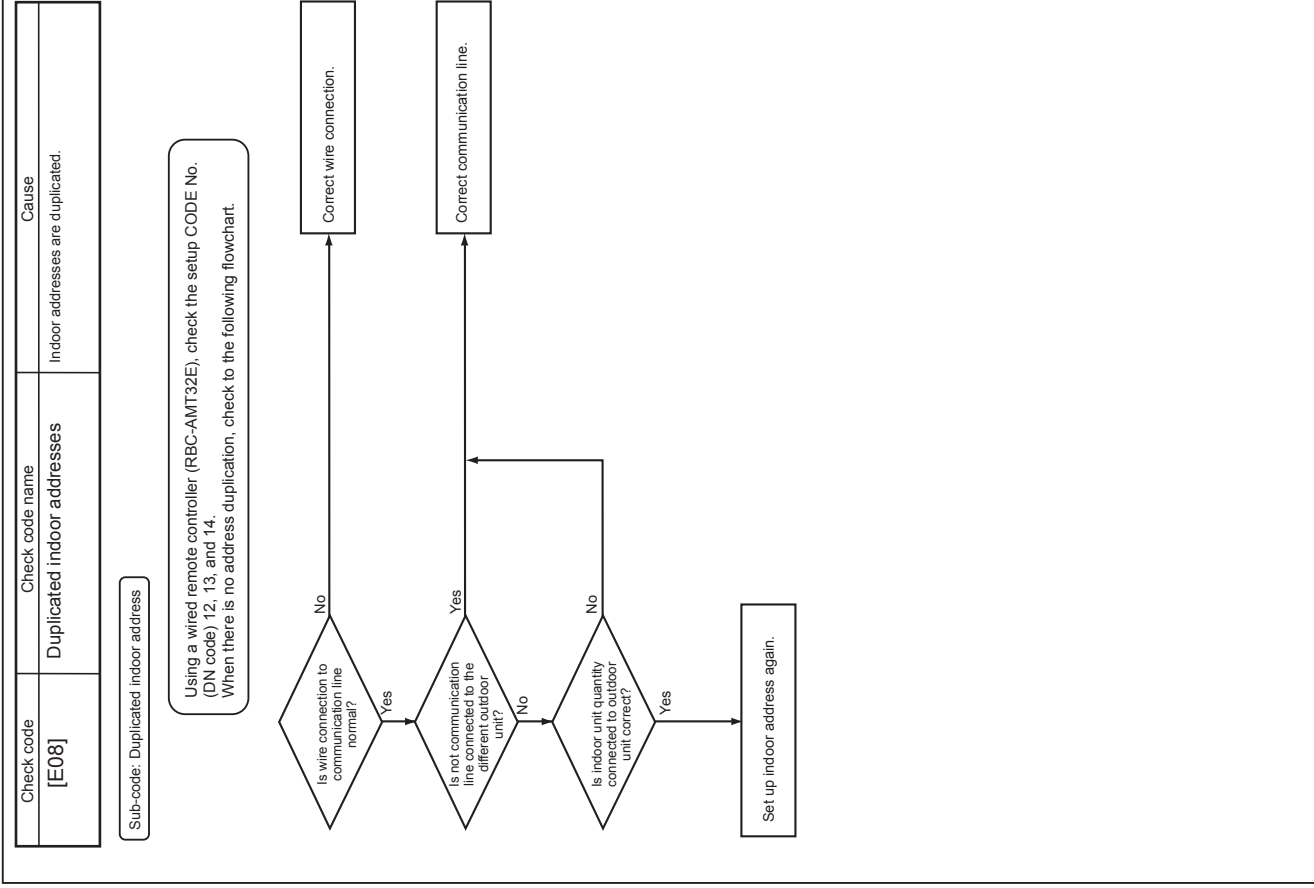

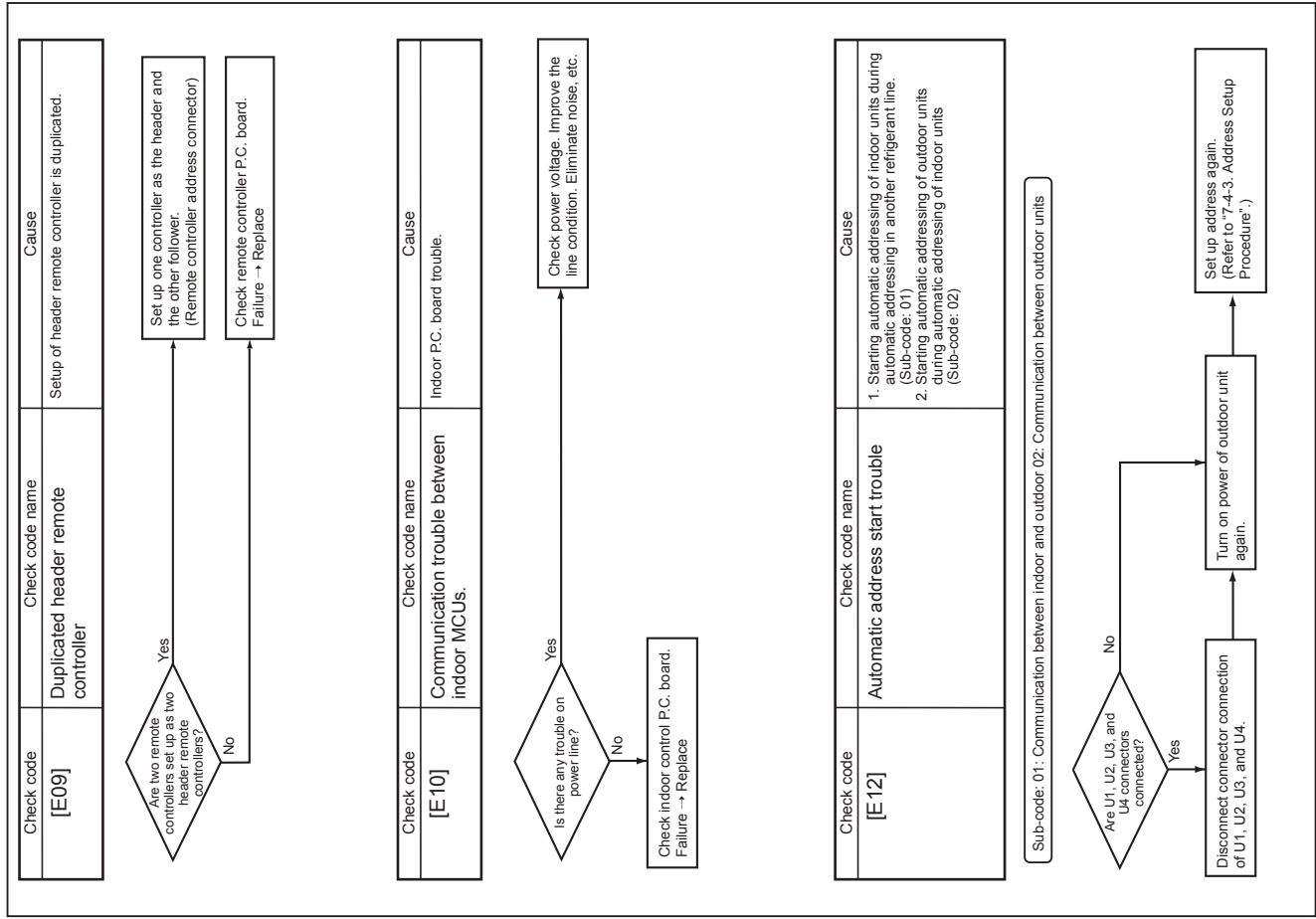
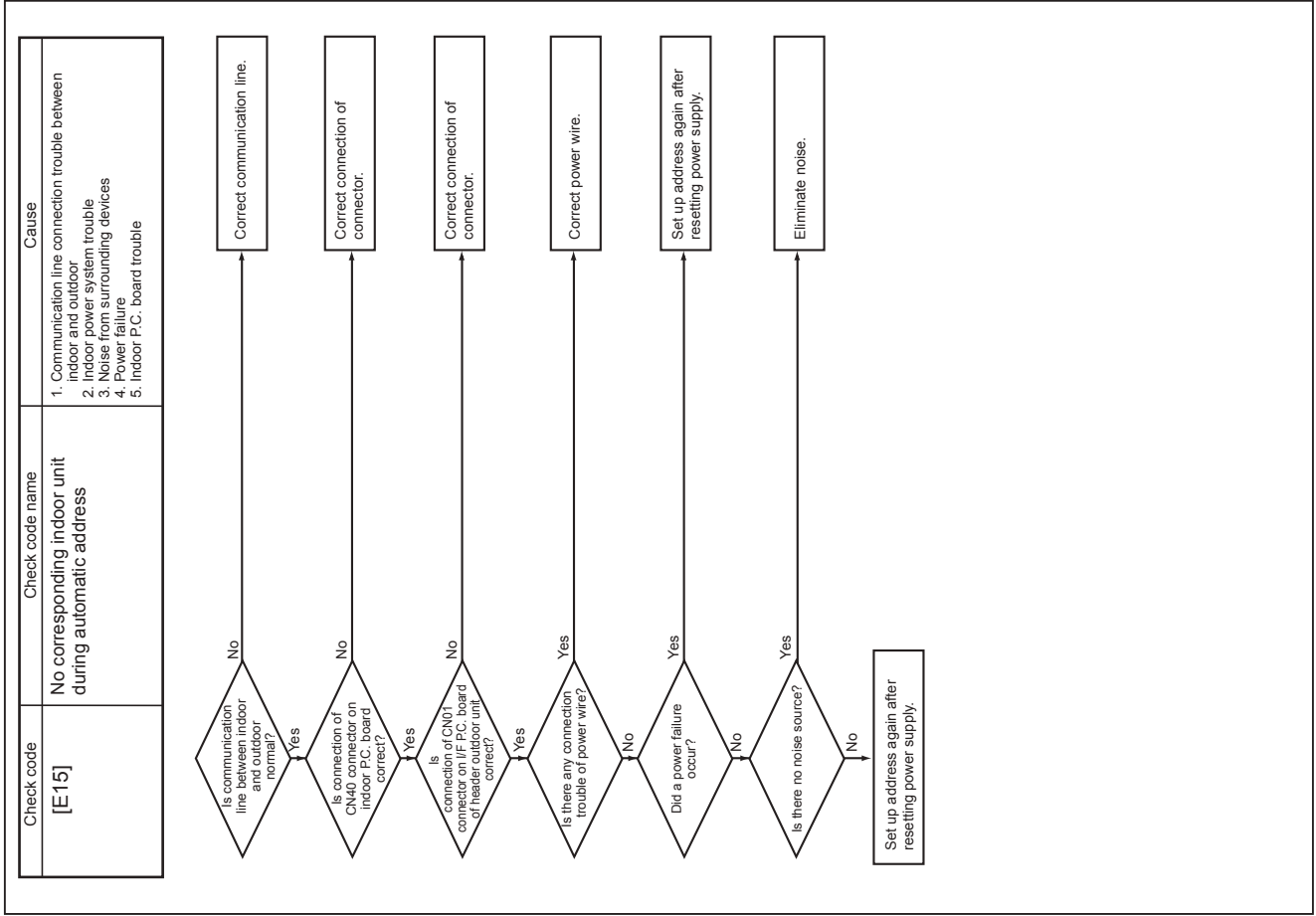

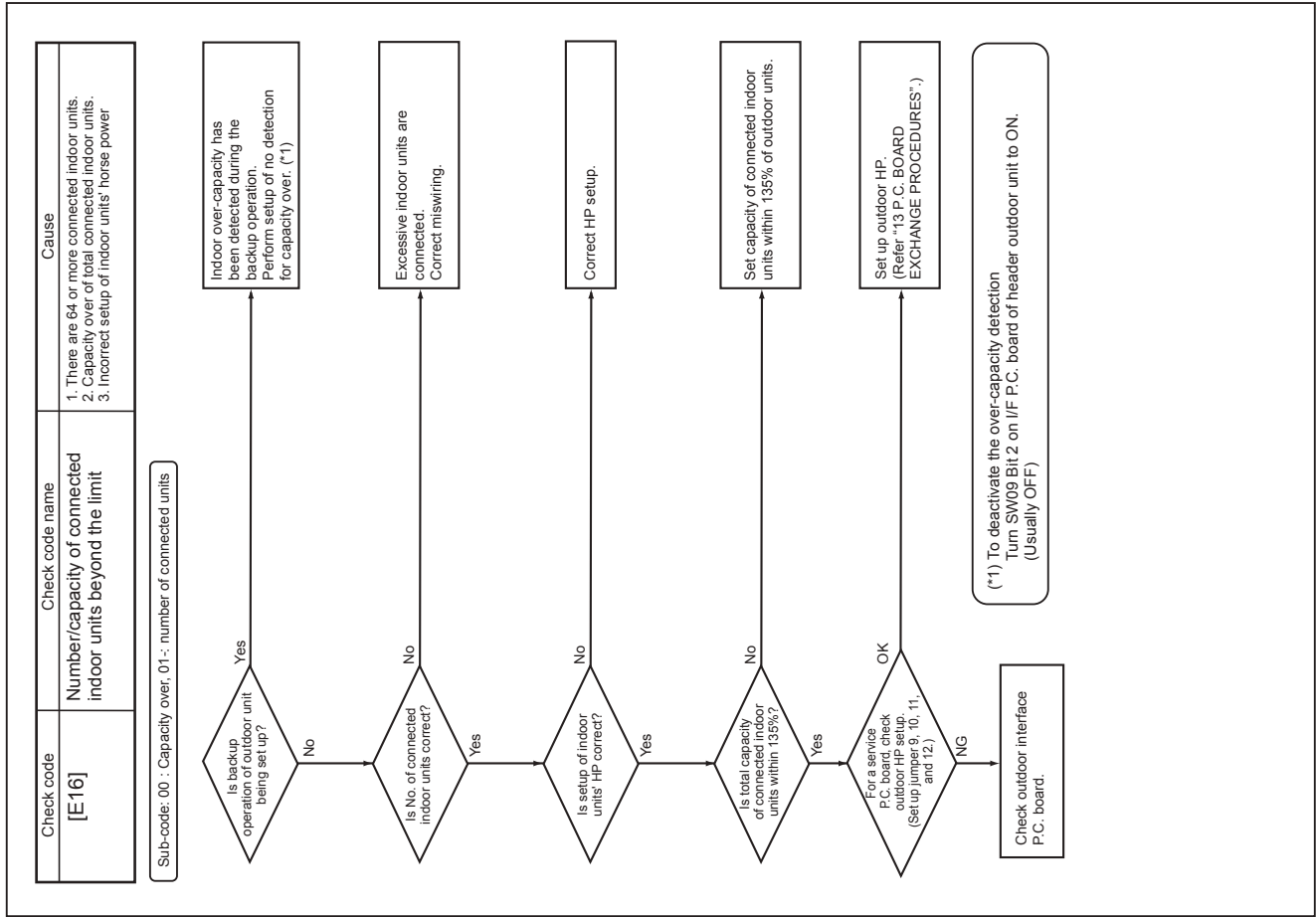
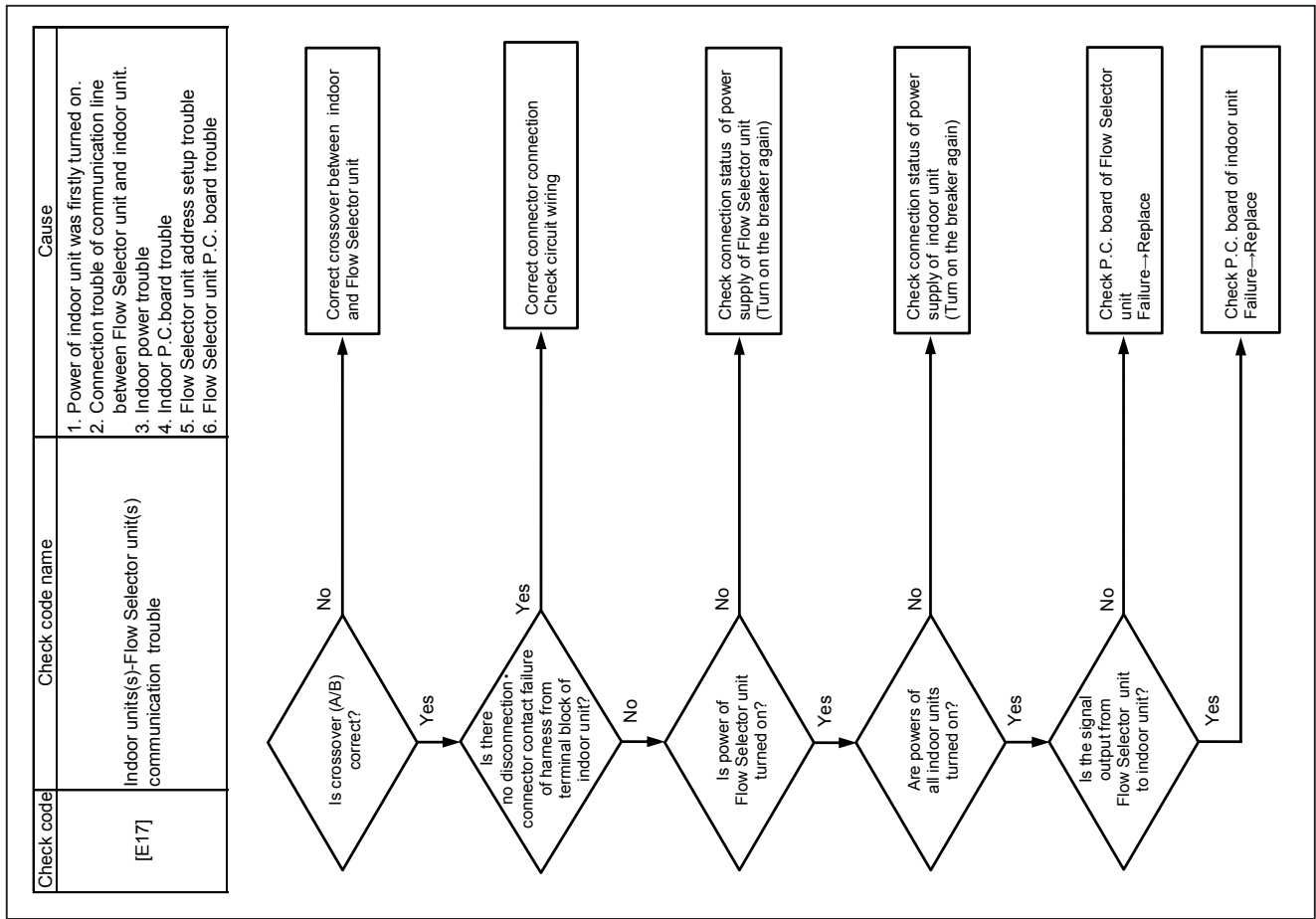

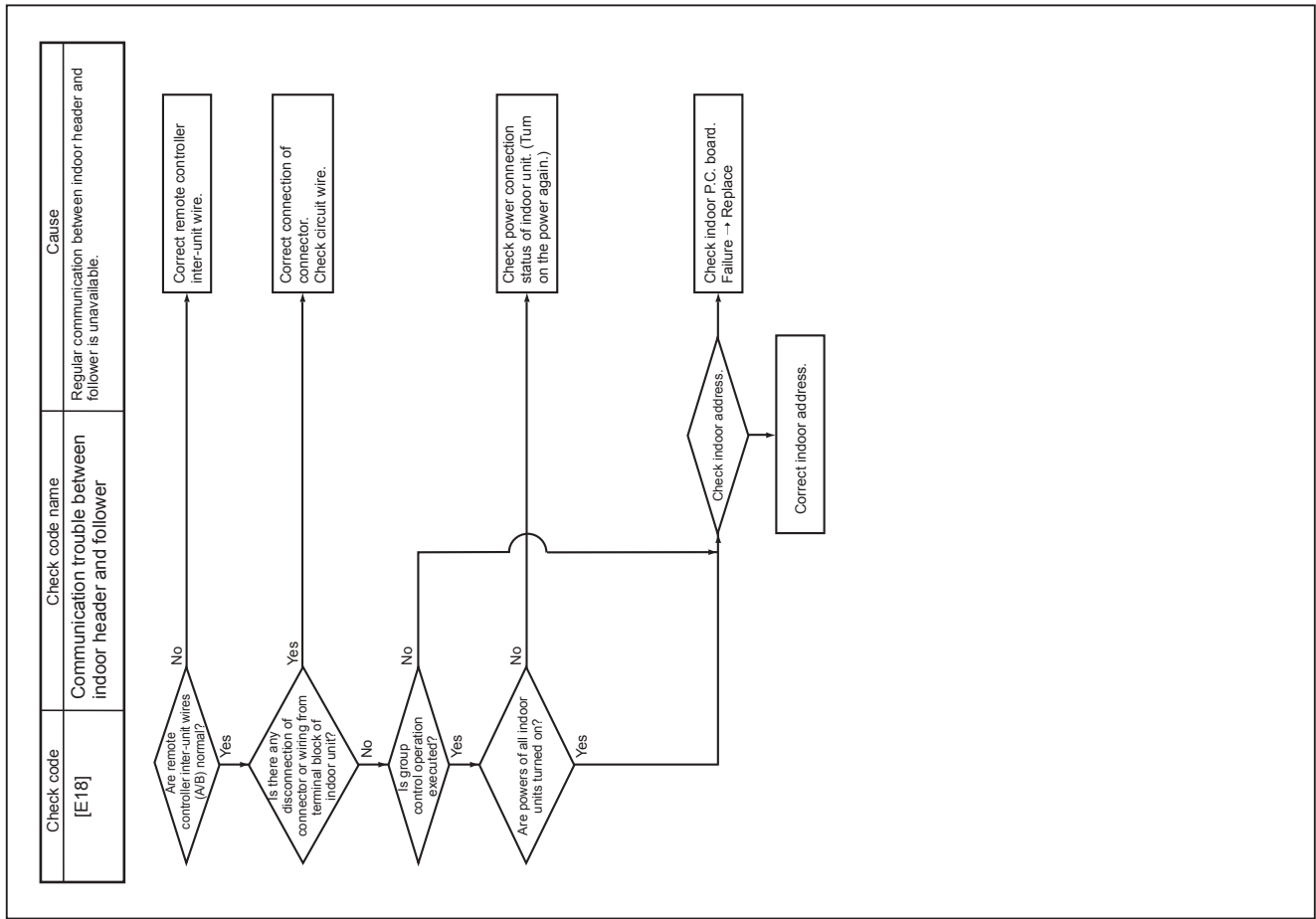
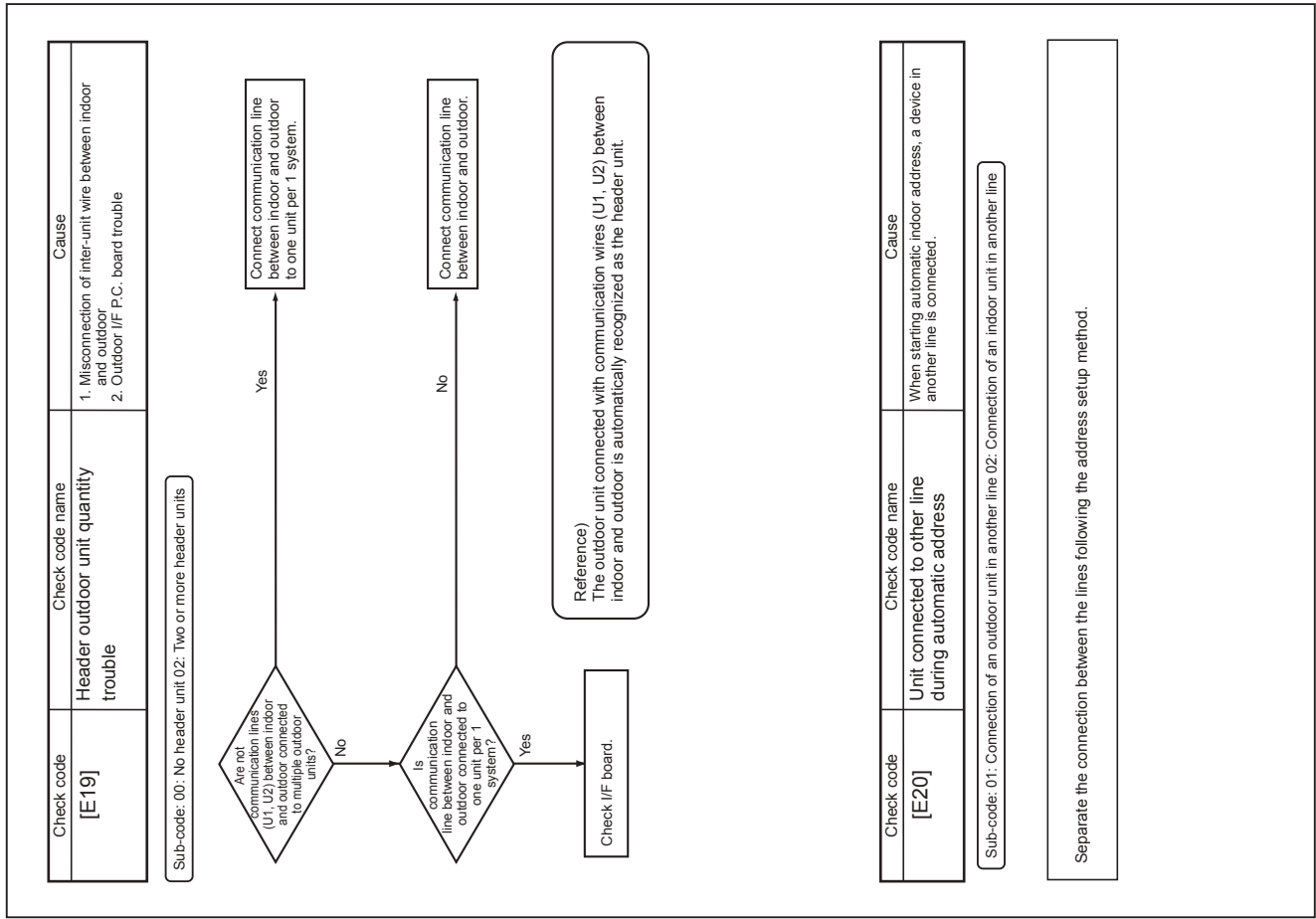

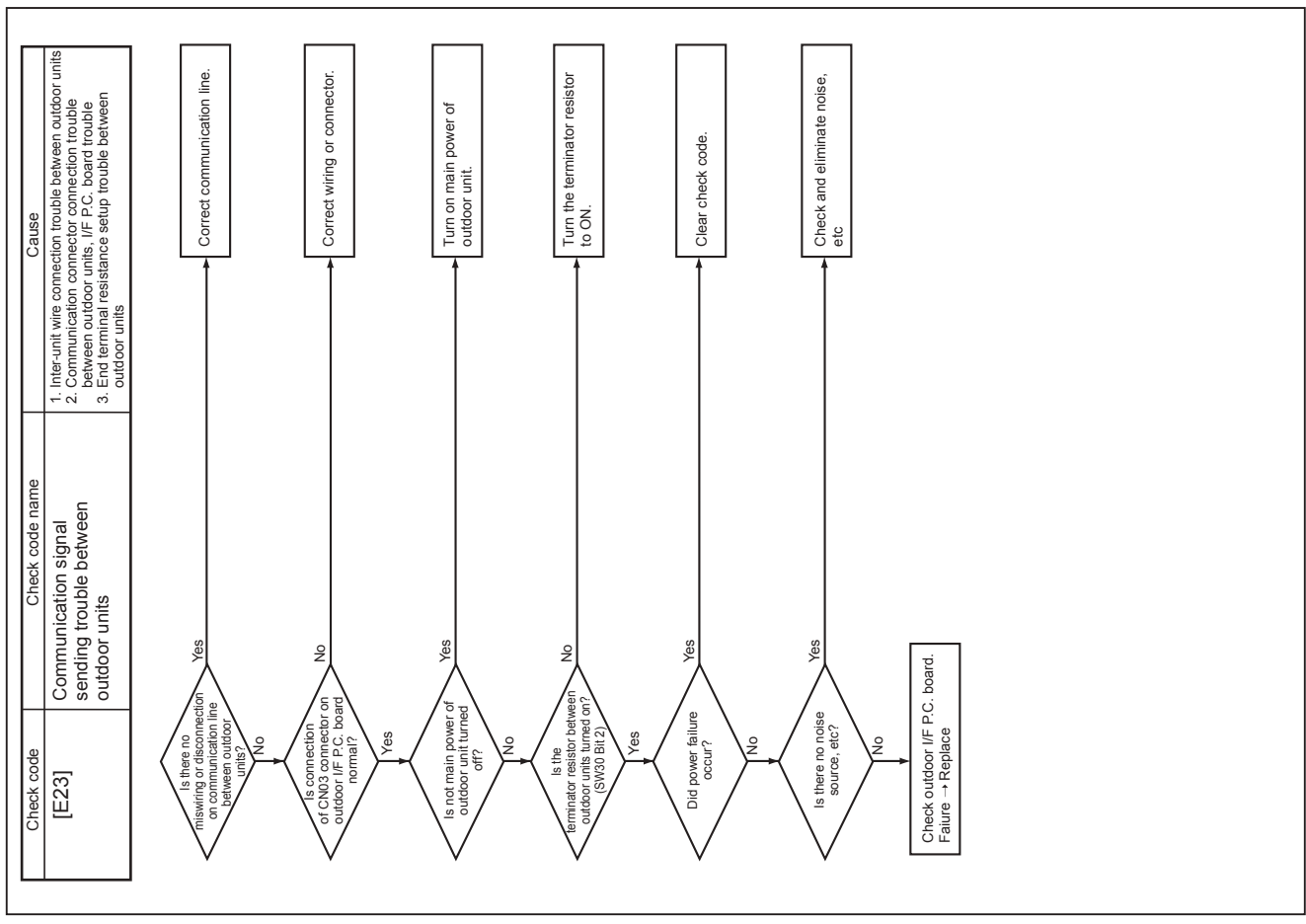
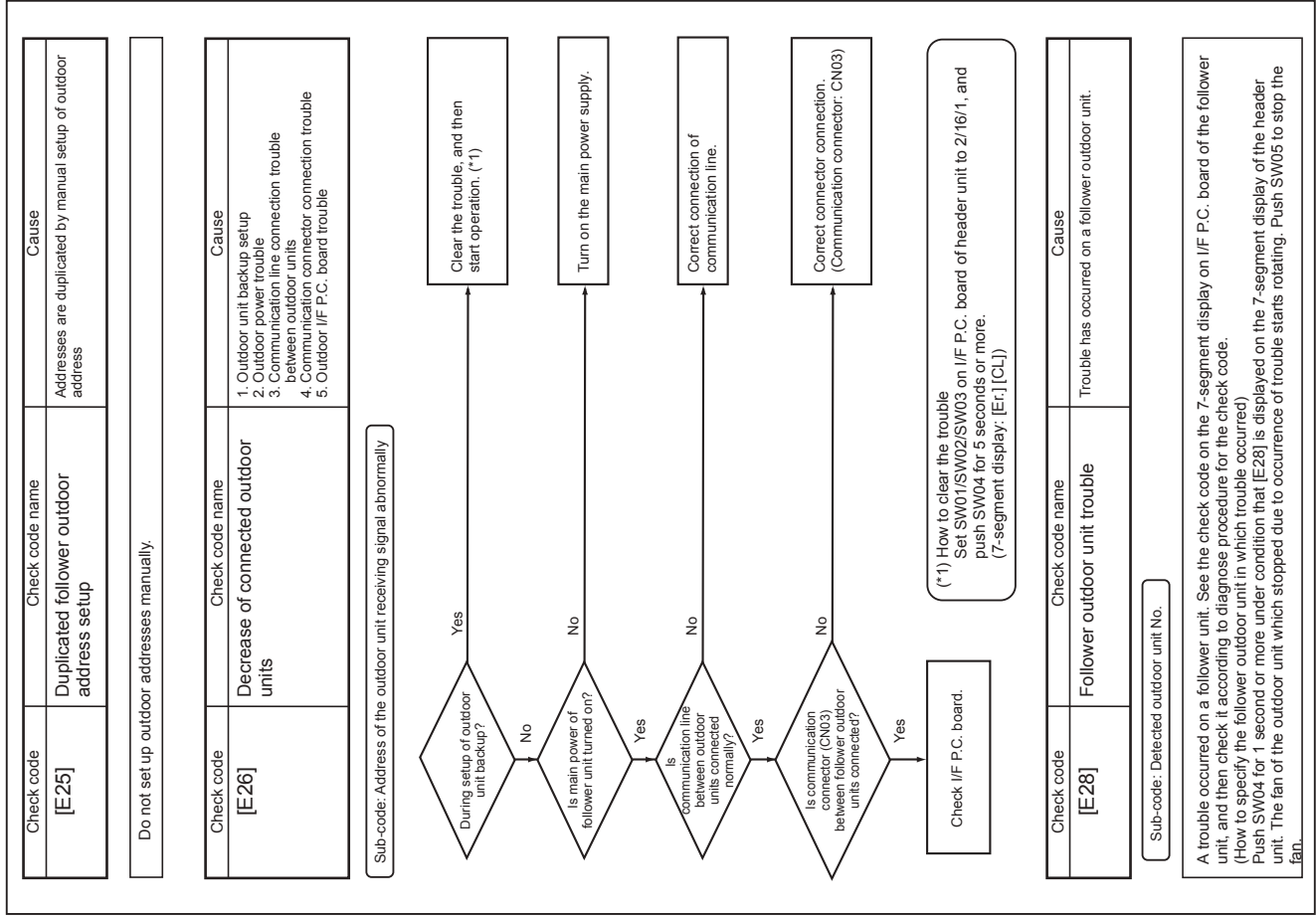

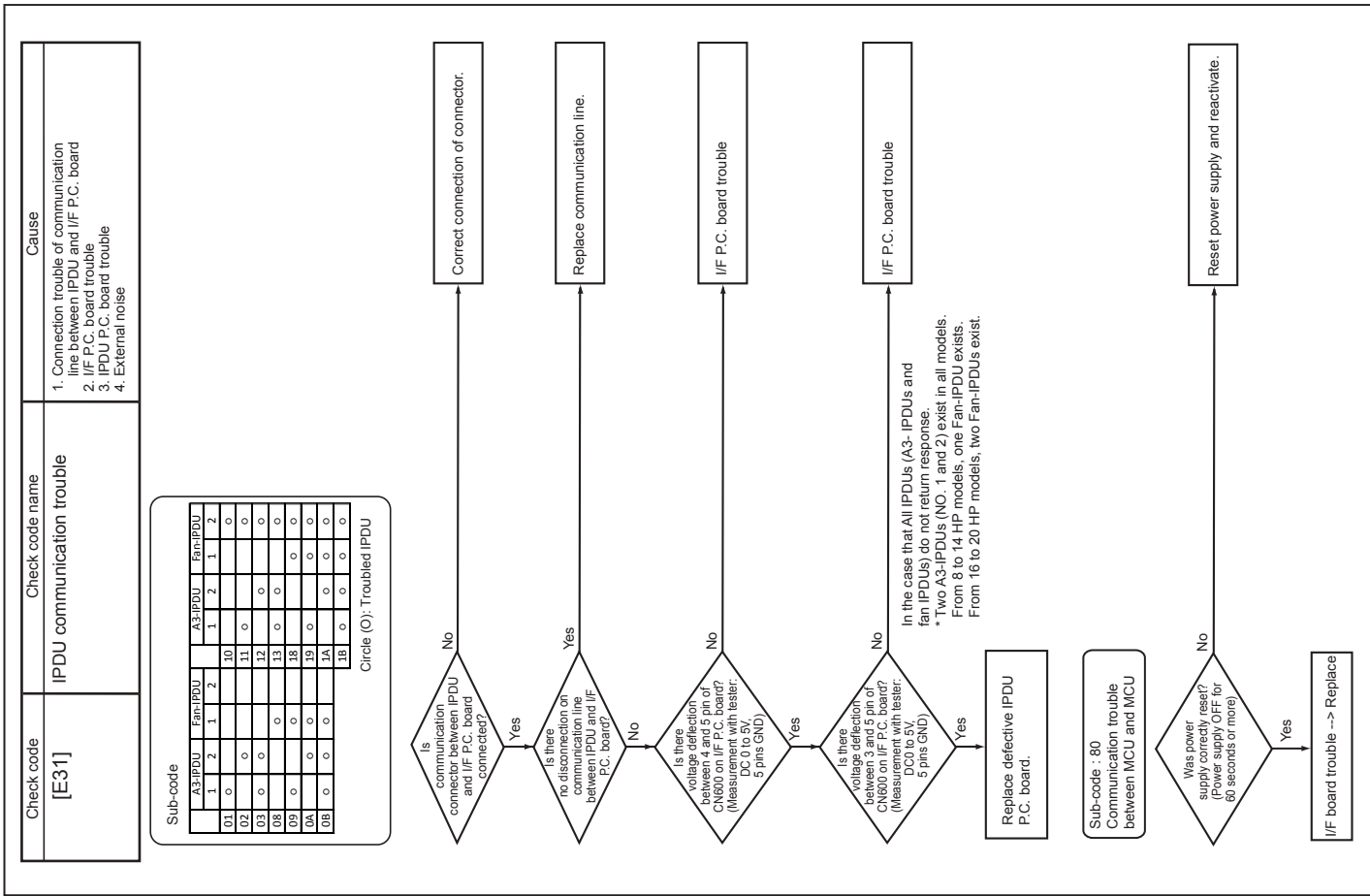
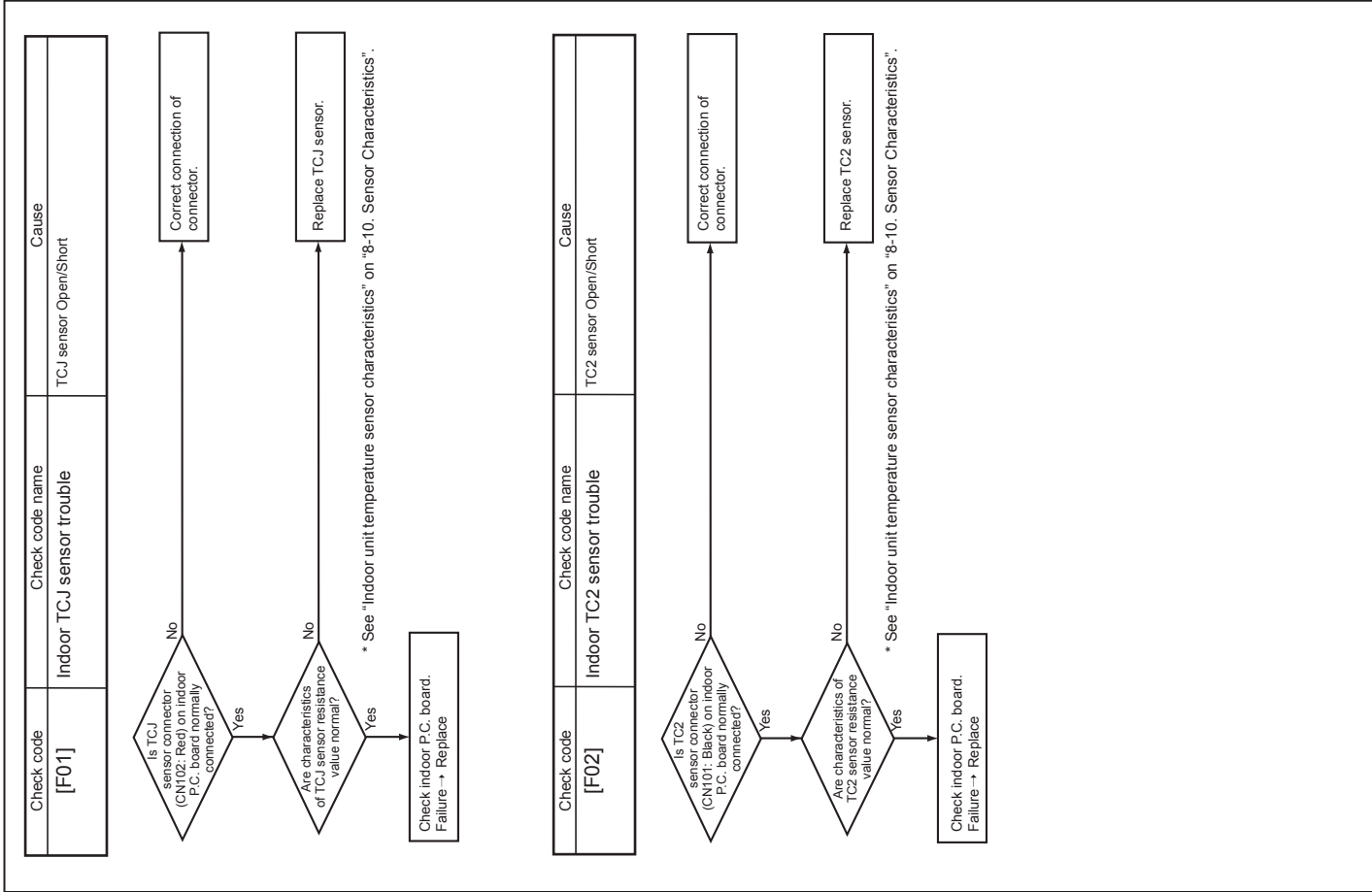

Check code	Check code name	Cause
[F07]	TL-1 sensor trouble	TL-1 sensor Open/Short

Sub-code: 01:TL1

This check code means detection of Open/Short of TL-1 sensor. Check disconnection of circuit for connection of connector (TL-1 sensor: CN523WH) and characteristics of sensor resistance value. (See "Outdoor unit temperature sensor characteristics" on "8-10. Sensor Characteristics".)
If sensor is normal, replace outdoor I/F P.C. board.

Check code	Check code name	Cause
[F08]	TO sensor trouble	TO sensor Open/Short

This check code means detection of Open/Short of TO sensor. Check disconnection of circuit for connection of connector (TO sensor: CN507, Yellow) and characteristics of sensor resistance value. (See "Outdoor unit temperature sensor characteristics" on "8-10. Sensor Characteristics".)
If sensor is normal, replace outdoor I/F P.C. board.

Check code	Check code name	Cause
[F10]	Indoor TA/TSA sensor trouble	TA sensor Open/Short

This check code means detection of Open/Short of TA sensor. Check disconnection of circuit for connection of connector (TA/TSA sensor: CN104, Yellow) and characteristics of sensor resistance value. (See "Indoor unit temperature sensor characteristics" on "8-10. Sensor Characteristics".)
If sensor is normal, replace indoor P.C. board.

Check code	Check code name	Cause
[F12]	TS1,TS2 sensor trouble	TS1,TS2 sensor Open/Short

Sub-code: 01:TS1, 02:TS2

This check code means detection of Open/Short of TS1,TS2 sensor. Check disconnection of circuit for connection of connector (TS1 sensor: CN505 WH, TS2 sensor: CN506 BLK) and characteristics of sensor resistance value. (See "Outdoor unit temperature sensor characteristics" on "8-10. Sensor Characteristics".)
If sensor is normal, replace outdoor I/F P.C. board.

Check code	Check code name	Cause
[F03]	Indoor TC1 sensor trouble	TC1 sensor Open/Short

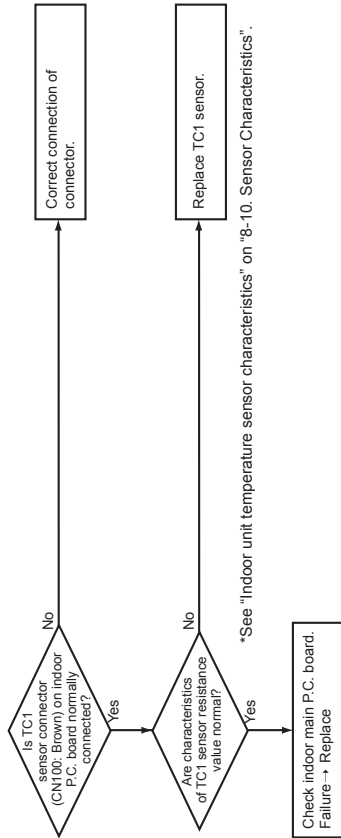

Check code	Check code name	Cause
[F04]	TD1 sensor trouble	TD1 sensor Open/Short

This check code means detection of Open/Short of TD1 sensor. Check disconnection of circuit for connection of connector (TD1 sensor: CN502, White) and characteristics of sensor resistance value. (See "Outdoor unit temperature sensor characteristics" on "8-10. Sensor Characteristics".)
If sensor is normal, replace outdoor I/F P.C. board.

Check code	Check code name	Cause
[F05]	TD2 sensor trouble	TD2 sensor Open/Short

This check code means detection of Open/Short of TD2 sensor. Check disconnection of circuit for connection of connector (TD2 sensor: CN503, Pink) and characteristics of sensor resistance value. (See "Outdoor unit temperature sensor characteristics" on "8-10. Sensor Characteristics".)
If sensor is normal, replace outdoor I/F P.C. board.

Check code	Check code name	Cause
[F06]	TE1, TE2 sensor trouble	TE1, TE2 sensor Open/Short

This check code means detection of Open/Short of TE1 sensor. Check disconnection of circuit for connection of connector (TE1 sensor: CN520, Green, TE2 sensor: CN521, Red) and characteristics of sensor resistance value. (See "Outdoor unit temperature sensor characteristics" on "8-10. Sensor Characteristics".)
If sensor is normal, replace outdoor I/F P.C. board.

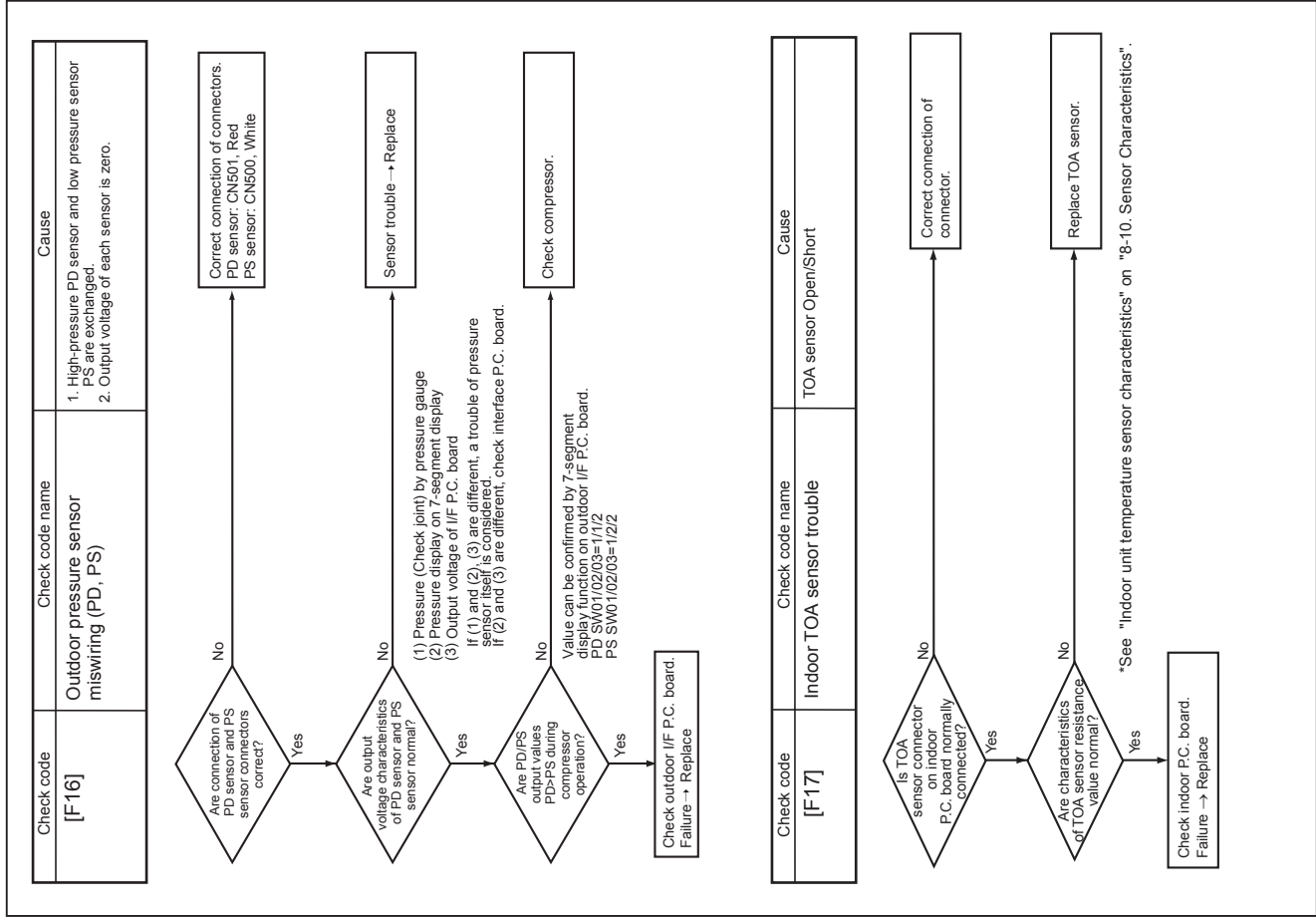
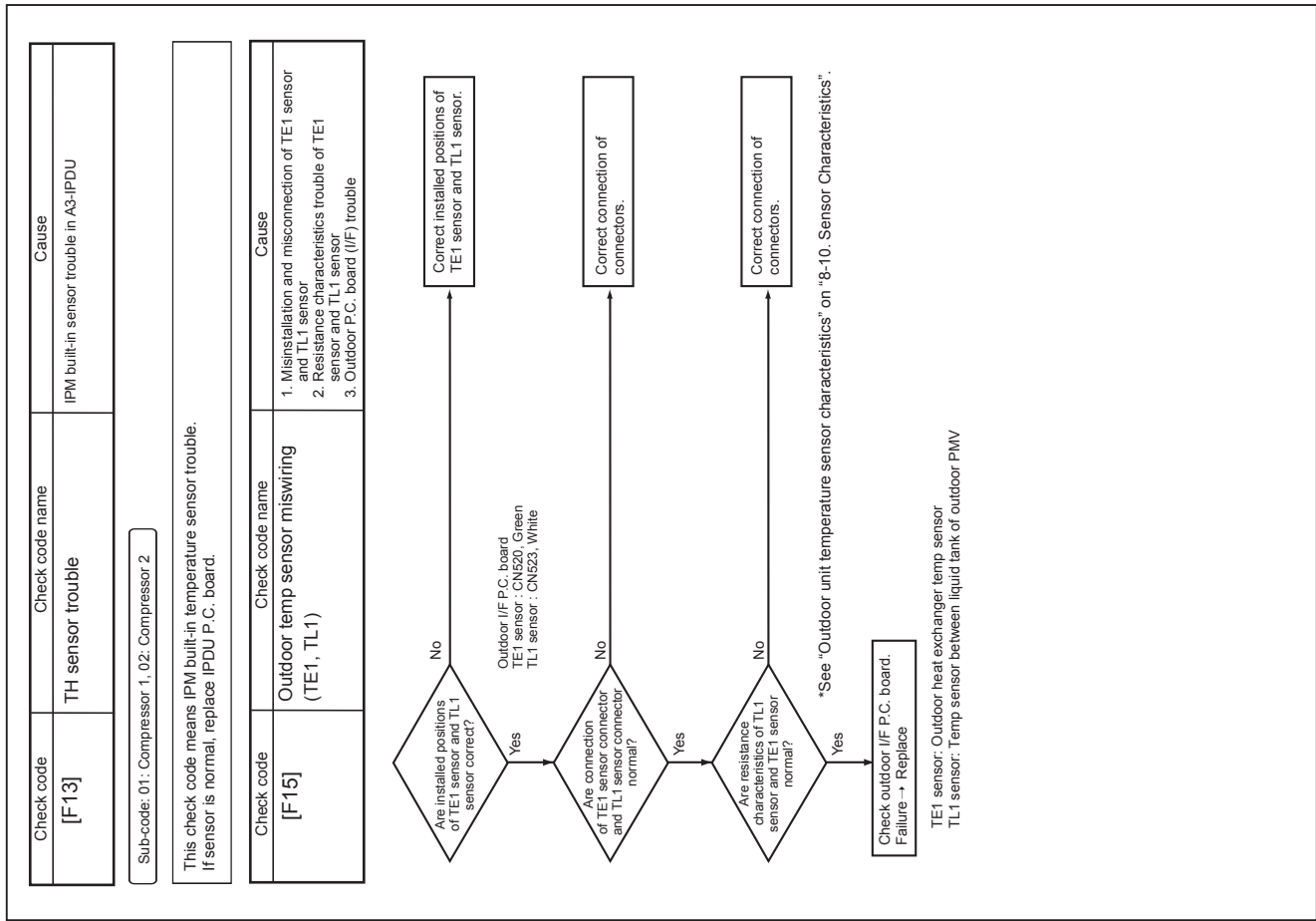

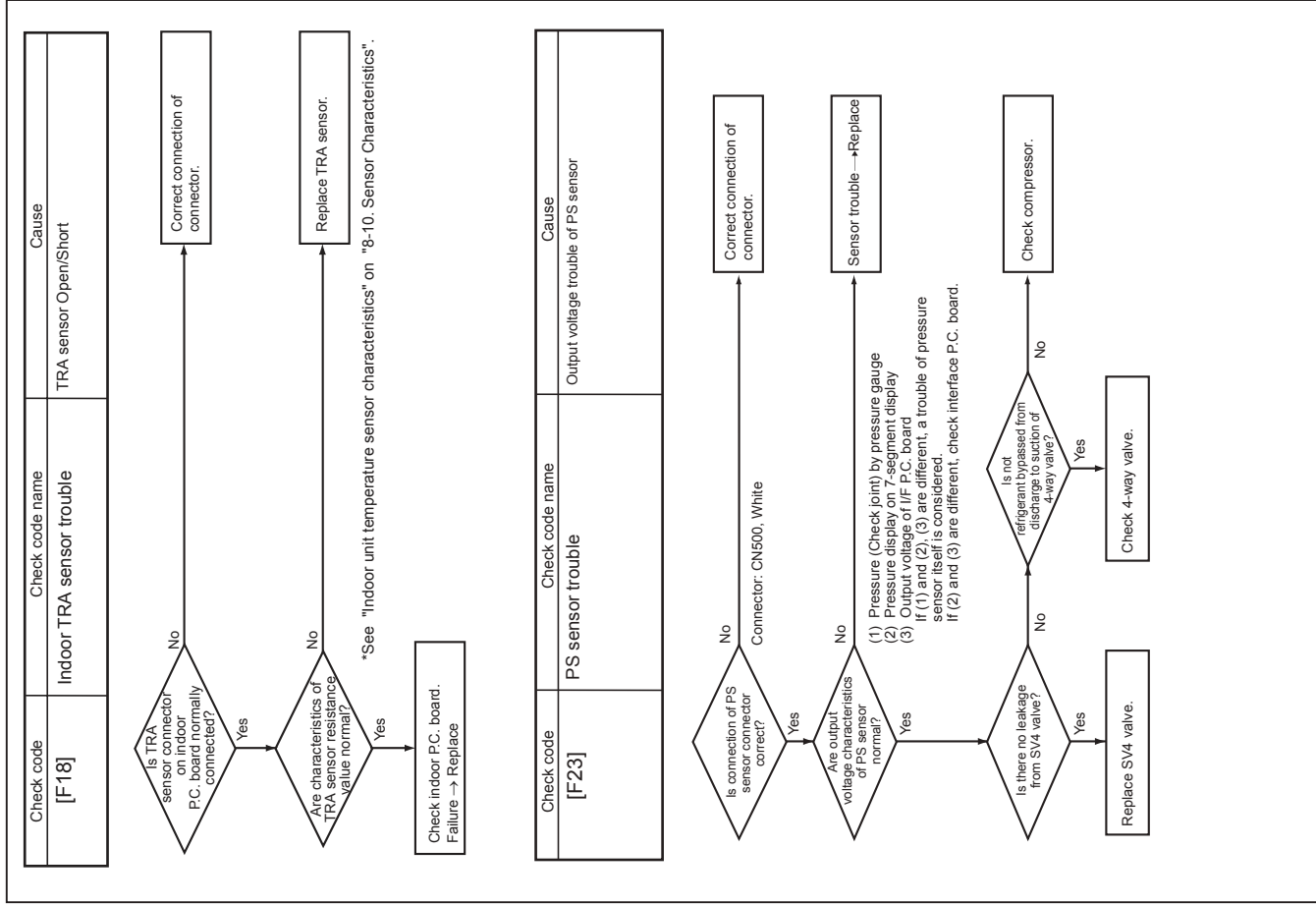
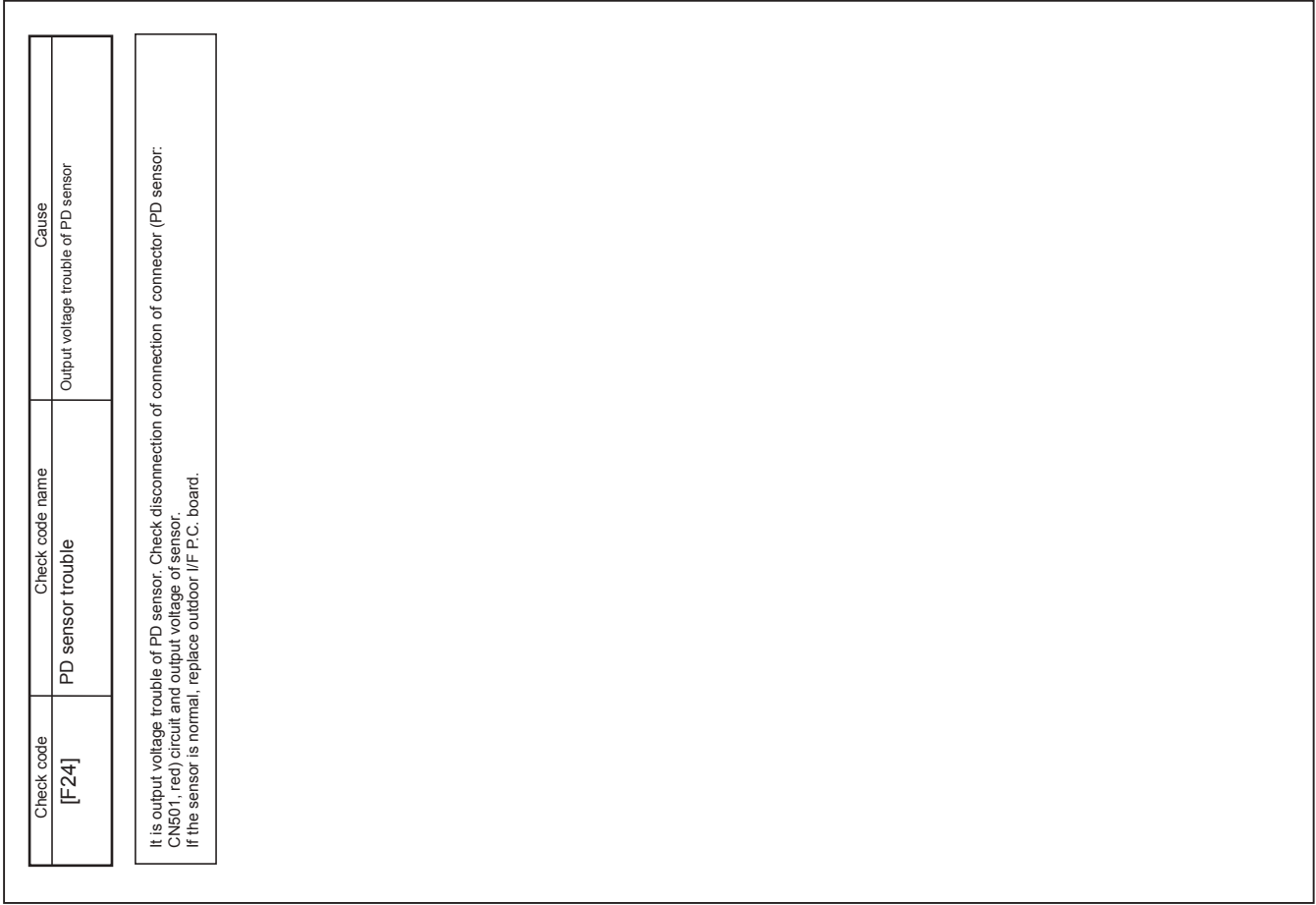

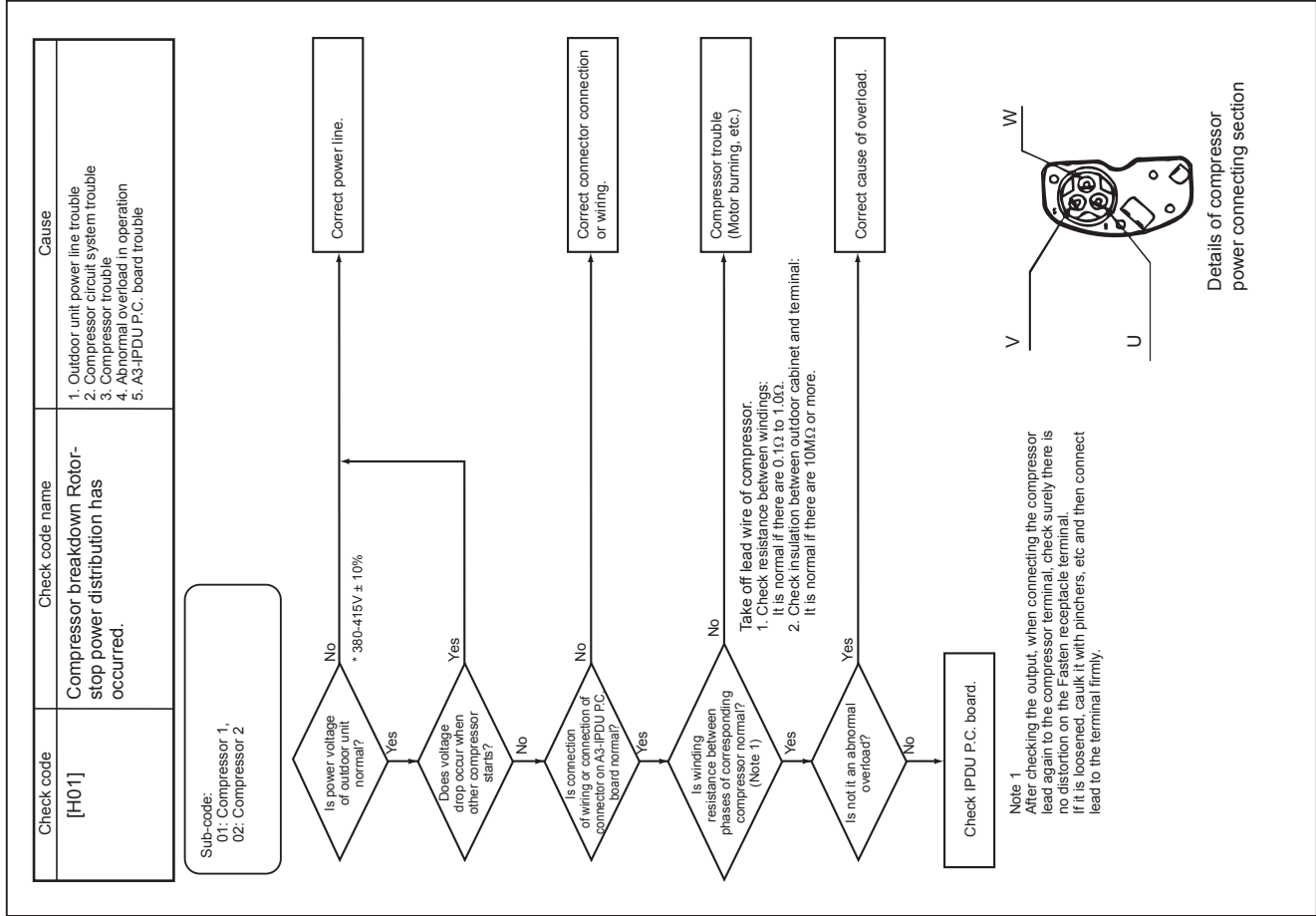
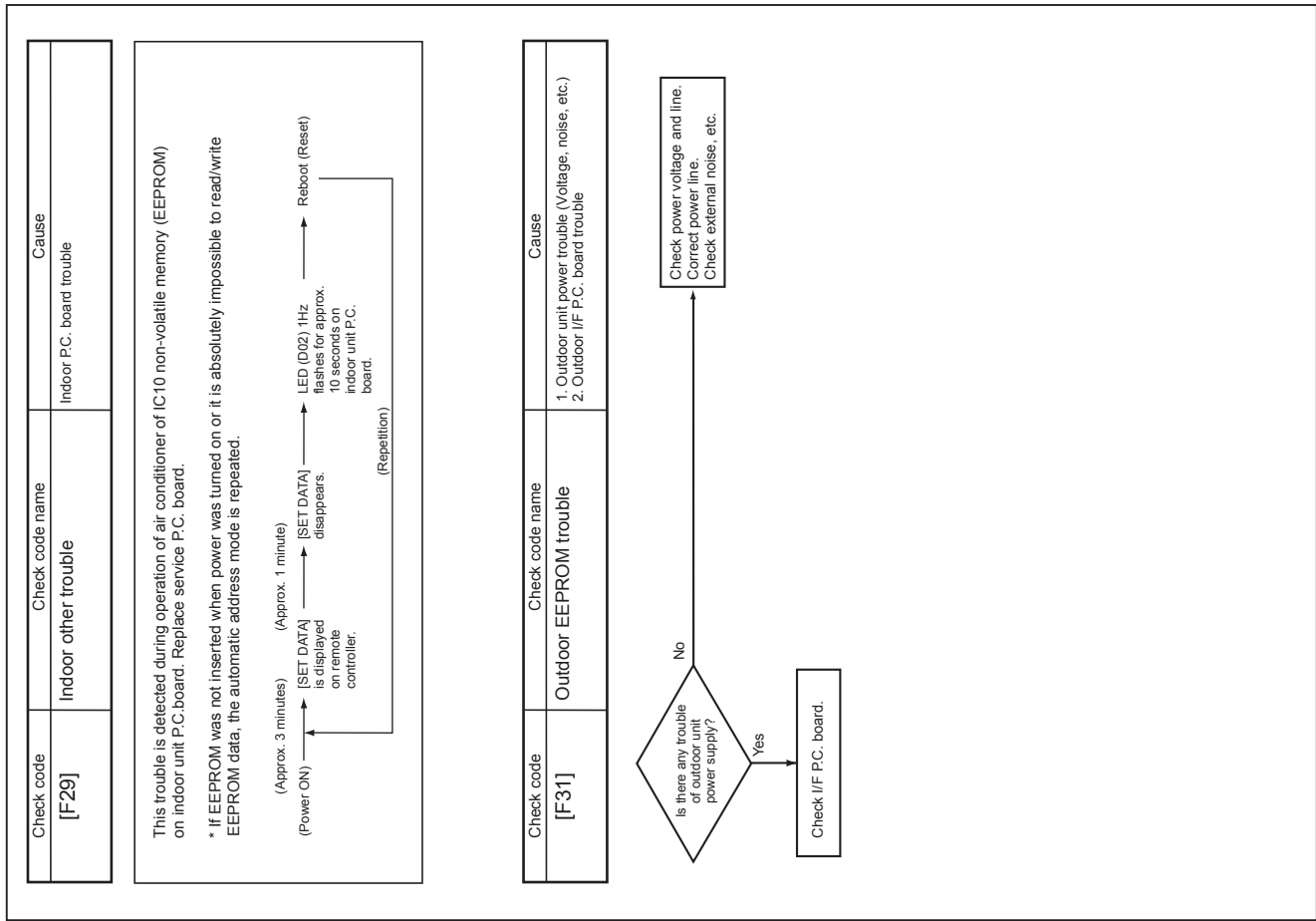

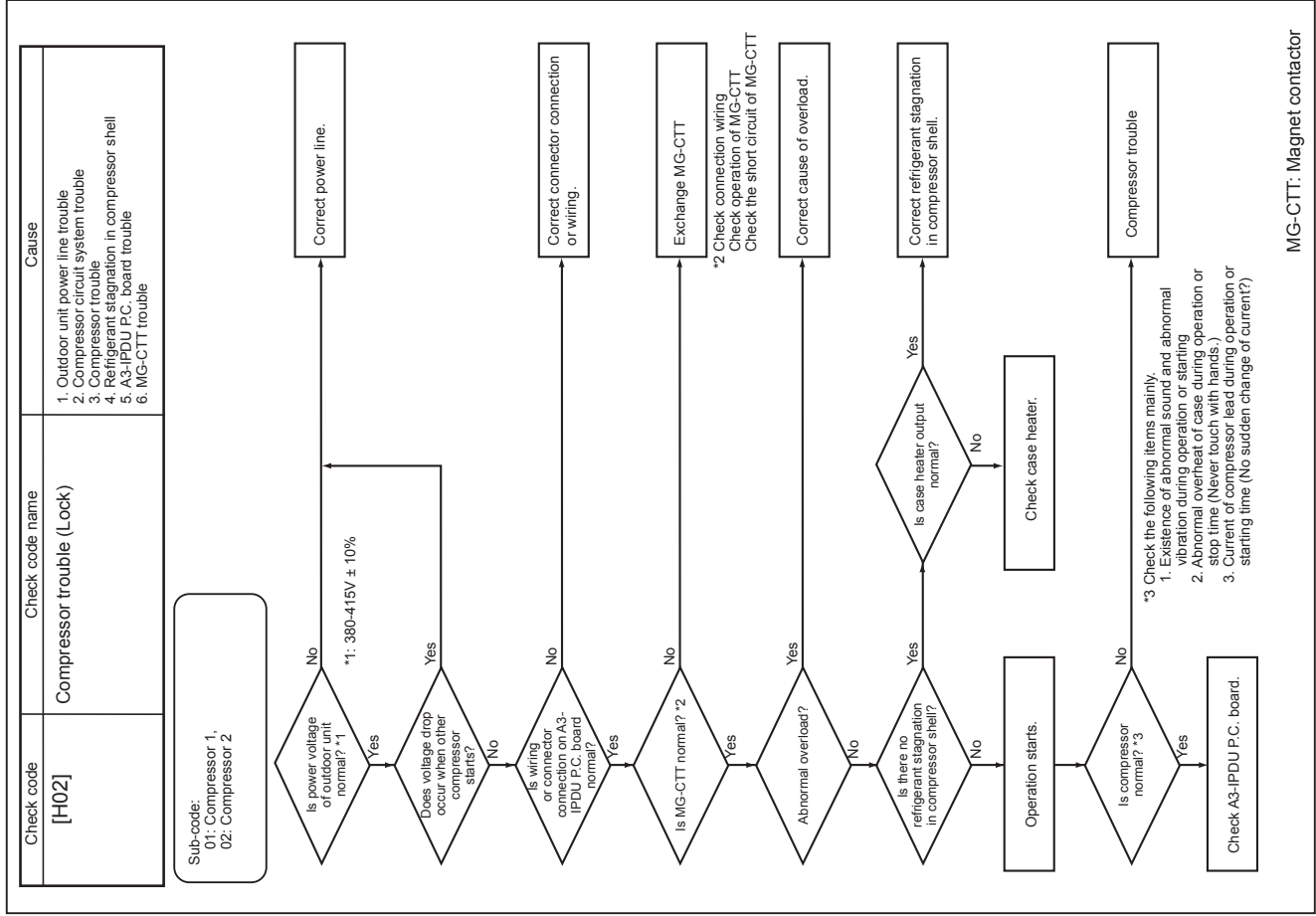
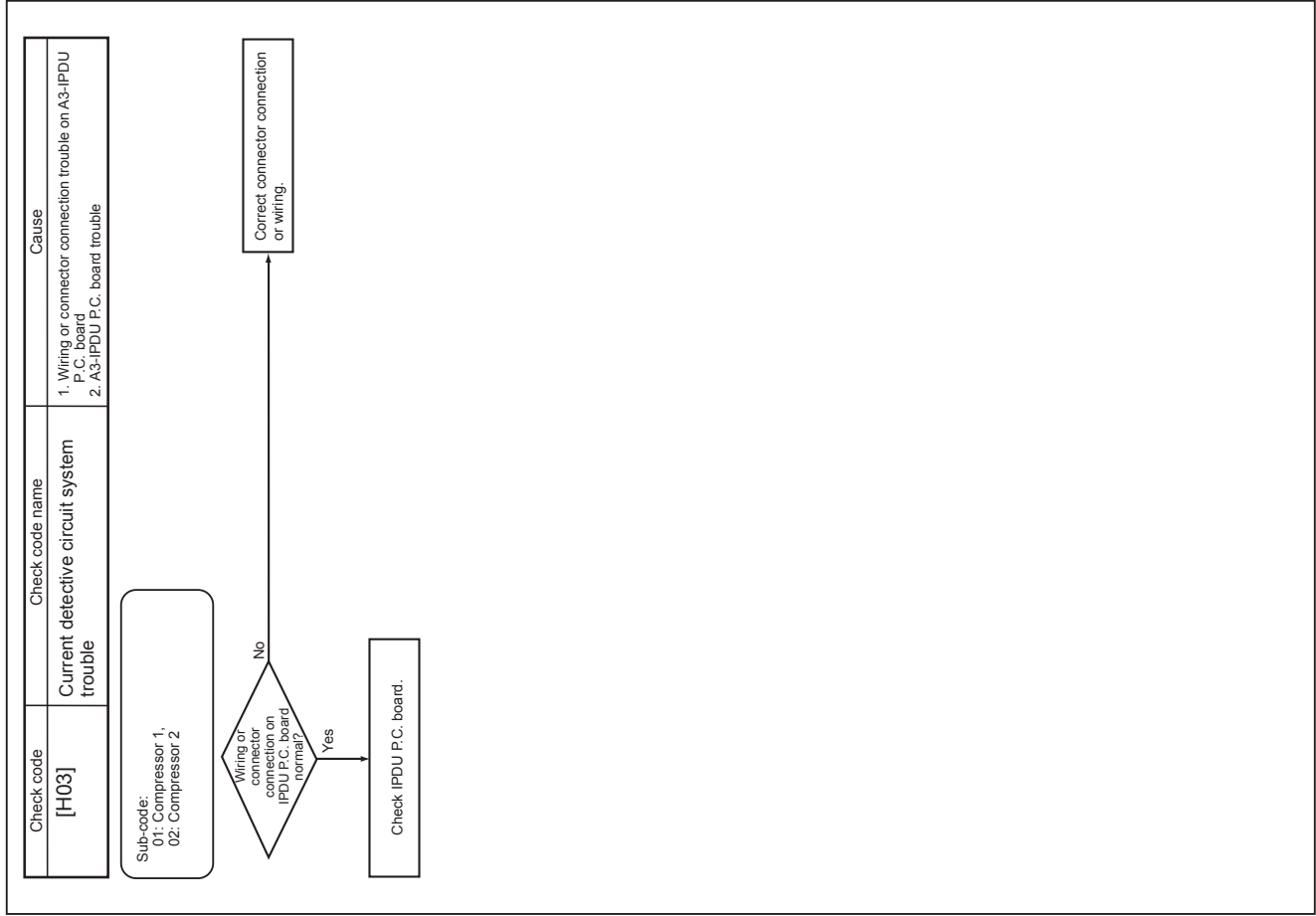

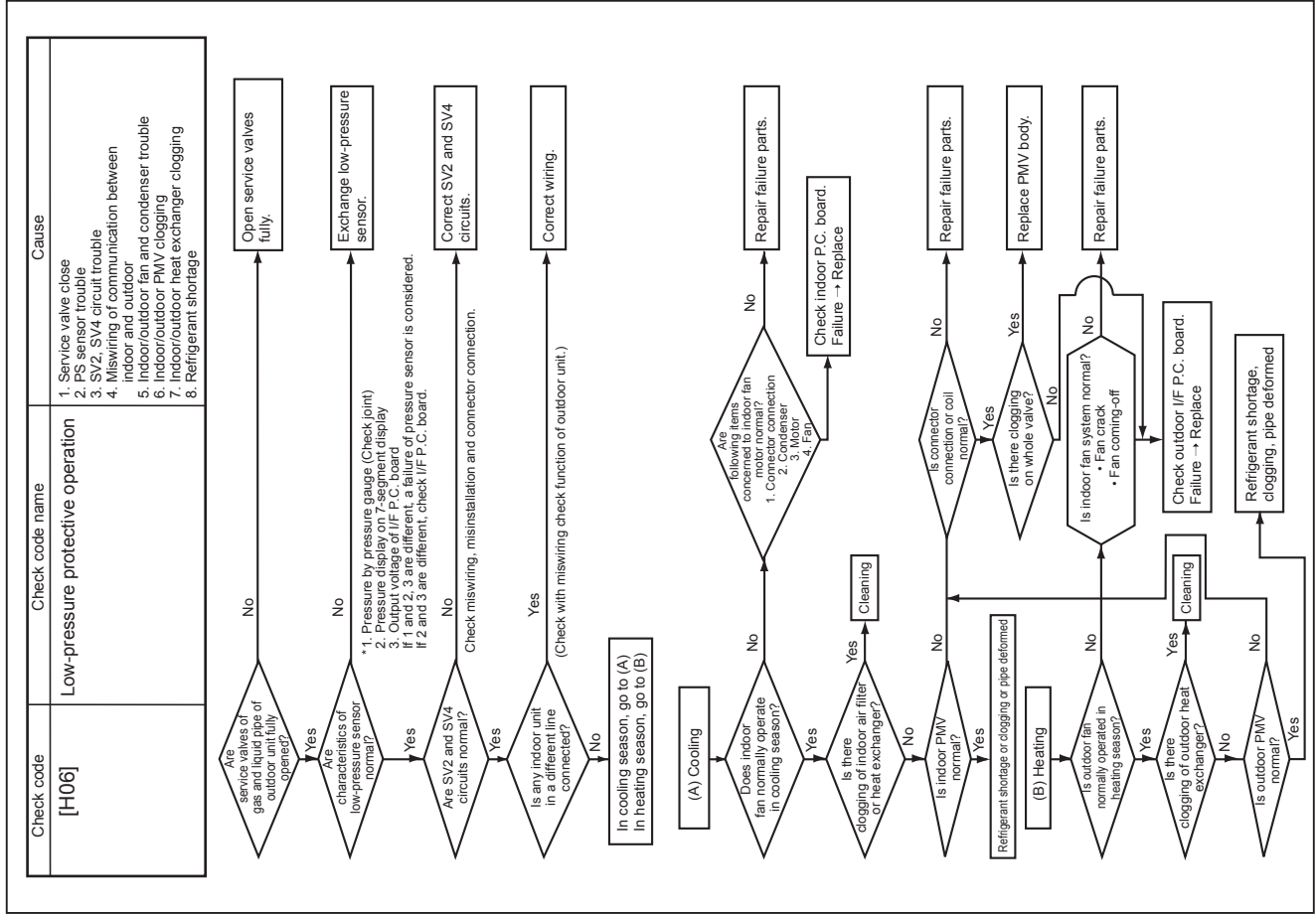
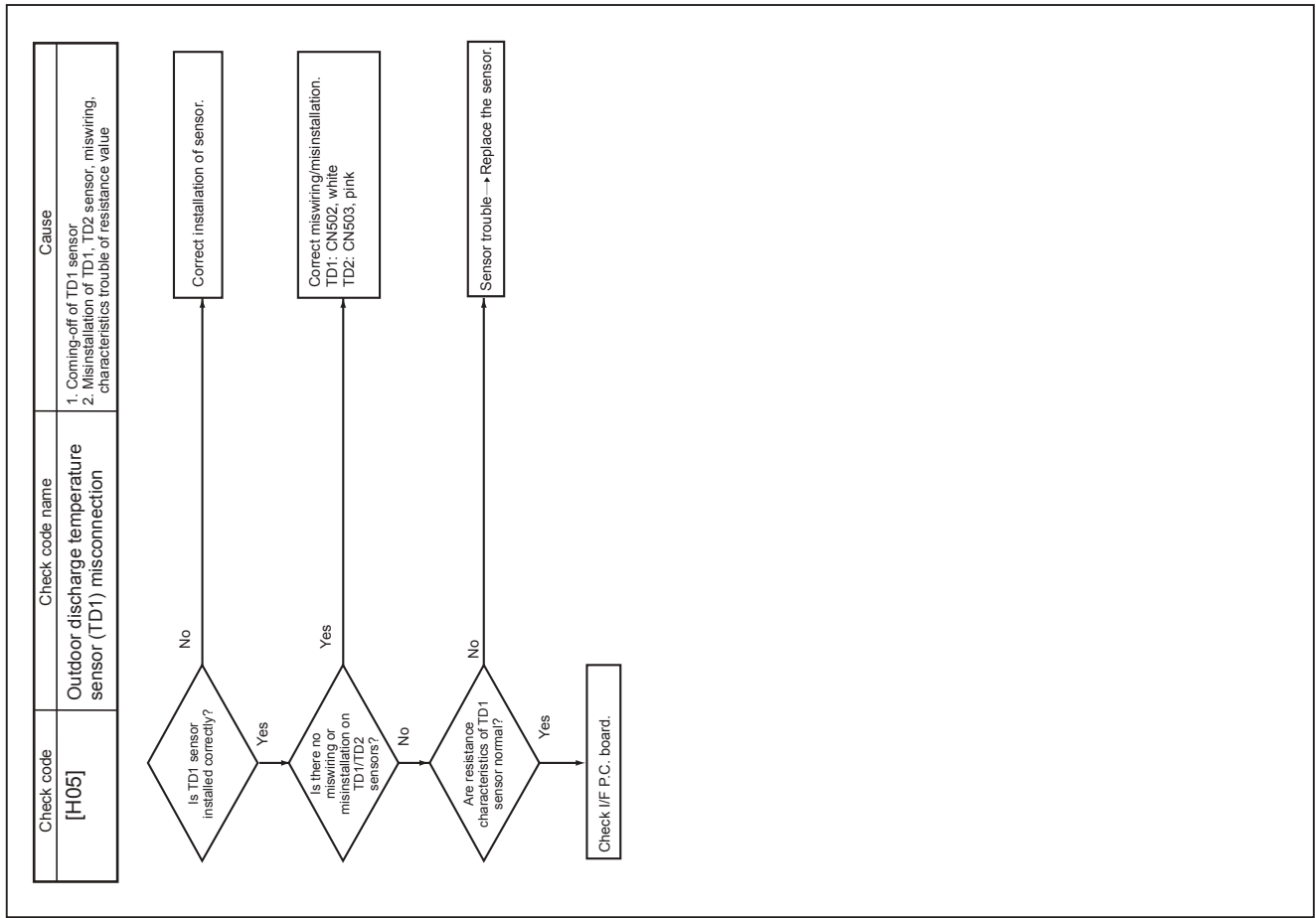

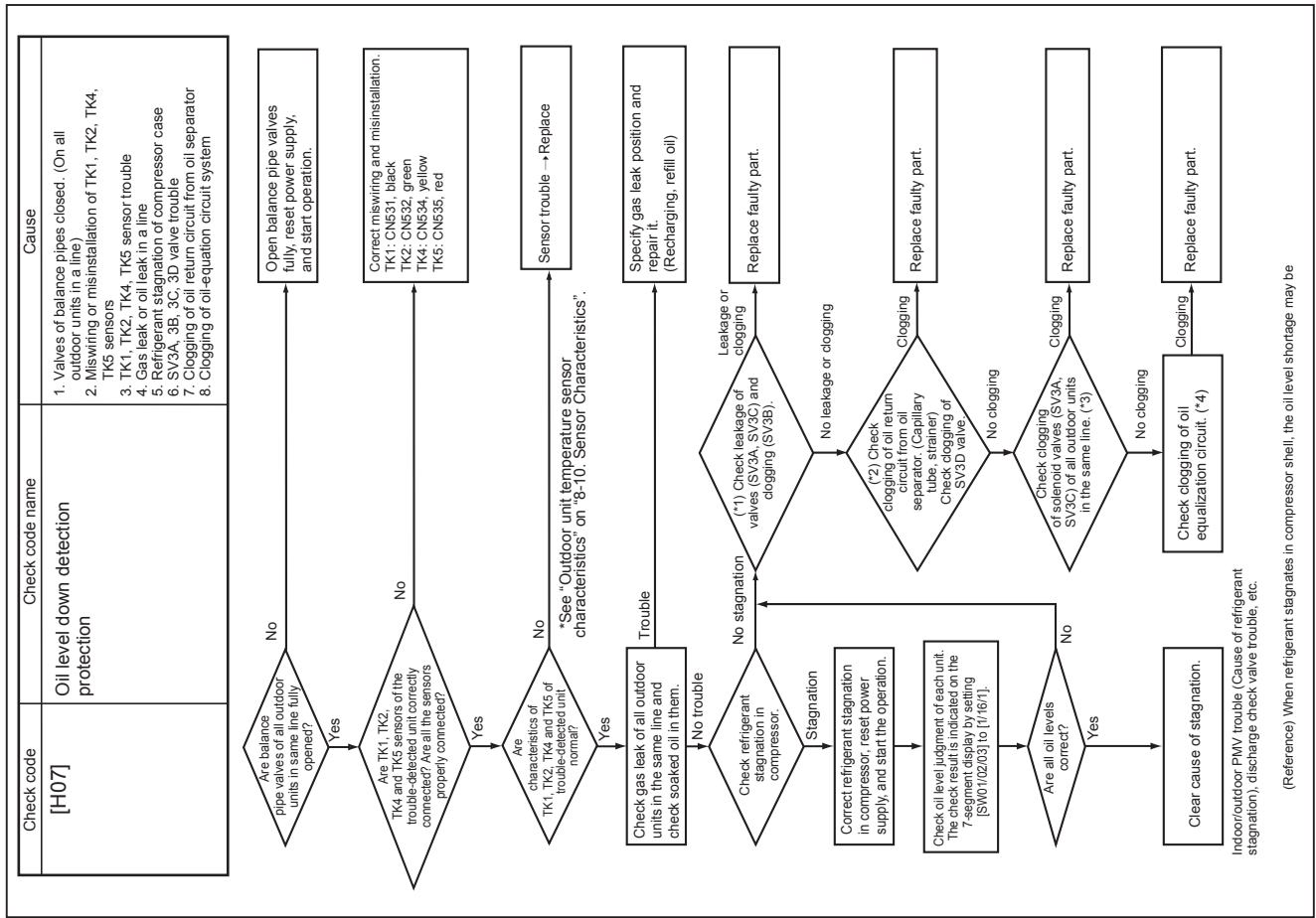

(*2) Checking the oil return circuit from oil separator and clogging in SV3D valve

- a) Oil return circuit**
- While outdoor unit is operating, check temperature (secondary side of capillary) on oil return circuit. ((6) in the figure.)
→ If temperature is low equivalent to suction temperature, a clogging of strainer of oil return circuit or capillary is considered. Replace the clogged part.
- b) Clogging check for SV3D valve**
- While outdoor unit is operated, set up SW01/02/03 = [2] [1] [3] (7-segment display [Hr] [... ..]), and push SW04 for 2 seconds or more.
 - Set up SW02 = [9], and turn on SV3D valve. (7-segment display [Hr] [... 3 dj])
 - If temperature is low at secondary side of the valve or it does not change, clogging of valve, capillary, or strainer is considered. ((7) in the figure.) Replace the clogged part.

In some cases, it may be difficult to check the leakage of clogging in the following condition of refrigerant stagnation in low ambient temperature condition.
In this case, take a longer operating time prior to check.
(Criterion: Discharge temperature of TD1 and TD2 are 60°C or higher)

(*1) Checking leakage and clogging on solenoid valves

- a) Leakage check for SV3A valve (For multiple outdoor unit system)**
- Turn off the power supply, take off connector of SV3A valve, and then start a test operation after power-ON.
 - Check the temperature change at secondary side of SV3A valve during operation. ((1) in the figure.)
→ If temperature is raised, leakage occurs in the SV3A valve. Replace SV3A valve.
- b) Leakage check for SV3C valve**
- Turn off the power supply, take off connector of SV3C valve, and then start a test operation after power-ON.
 - After operation for several minutes, check temperature at secondary side of SV3C valve. ((2) in the figure.)
→ If temperature is high (equivalent to discharge temperature TD), leakage occurs in the SV3C valve. Replace SV3C valve.
(Even if leakage does not occur in the SV3C valve, temperature of SV3C valve at secondary side rises during operation. But the temperature is lower than TD when there is no leakage.)
- c) Clogging check for SV3B valve (For multiple outdoor unit system)**
- While outdoor unit is operated, set up SW01/02/03 = [2] [1] [3] (7-segment display [Hr] [... ..]), and push SW04 for 2 seconds or more.
 - Set up SW02 = [10], and turn on SV3A, SV3B, SV3C valves. (7-segment display [Hr] [... 3 -])
 - While outdoor units are operating, check temperature change at secondary side of SV3B valve. ((4) in the figure.)
→ If temperature does not rise (equivalent to suction temperature), it is a clogging of SV3B valve. Replace SV3B valve.

MMY-MAP0806*
 MMY-MAP1006*
 MMY-MAP1206*
 MMY-MAP1406*
 MMY-MAP1606*
 MMY-MAP1806*
 MMY-MAP2006*

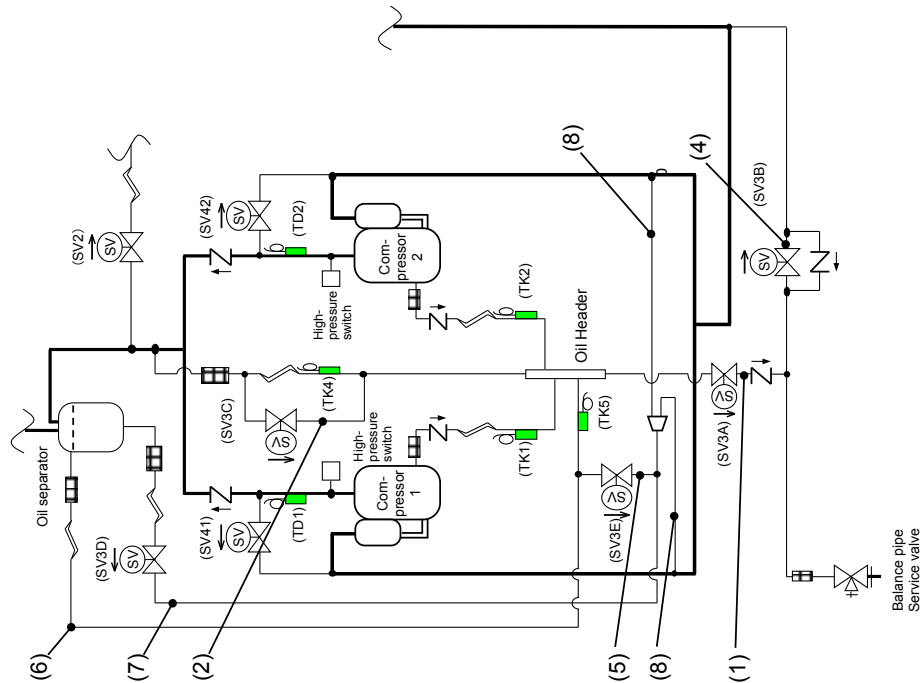

(*3) Check for solenoid valve of all outdoor units in a line (For multiple outdoor unit system)

a) Clogging check for SV3A valve

- While outdoor unit is operating, set up SW01/02/03 = [2][1][3] (7-segment display [Hr] [... ..]), and push SW04 for 2 seconds or more.
- Set up SW02 = [6], and turn on SV3A valve. (7-segment display [Hr] [... 3 A])
- If temperature is low at secondary side of the valve or it does not change, clogging of valve or check valve is considered. ((1) in the figure.)

b) Leakage check for SV3C valve

- While outdoor unit is operating, set up SW01/02/03 = [2][1][3] (7-segment display [Hr] [... ..]), and push SW04 for 2 seconds or more.
- Set up SW02 = [8], and turn on SV3C valve. (7-segment display [Hr] [... 3 C])
- If temperature does not change (up), clogging of valve or strainer is considered. ((2) in the figure.)

(*4)

a) Clogging check for oil-equalization circuit

- Drive the outdoor unit. (Drive all compressors in the unit.)
- After driving for 10 minutes or more, check whether temperature of TK1, TK2 sensors and temperature of oil-equalization circuit capillary ((8) in the figure) has increased. (Criterion)
 TK1, TK2=Td1, Td2 temperature - Approx. 10 to 30°C
 Oil-equalization capillary tubes should be higher sufficiently than outside air temperature and suction temperature.
- If temperature is low, a malfunction on check valves or clogging of capillary, strainer or distributor is considered. Repair the defective parts.

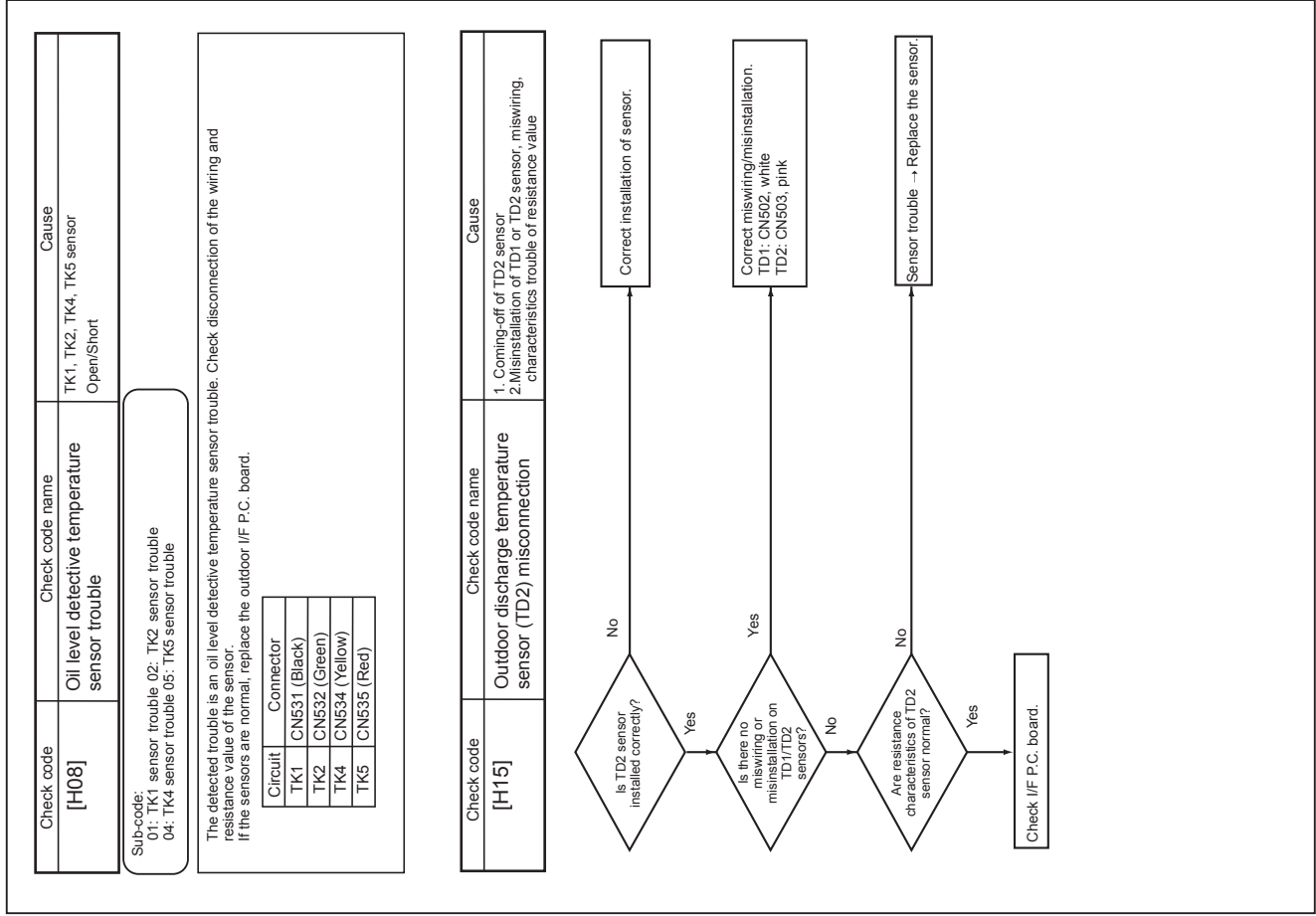
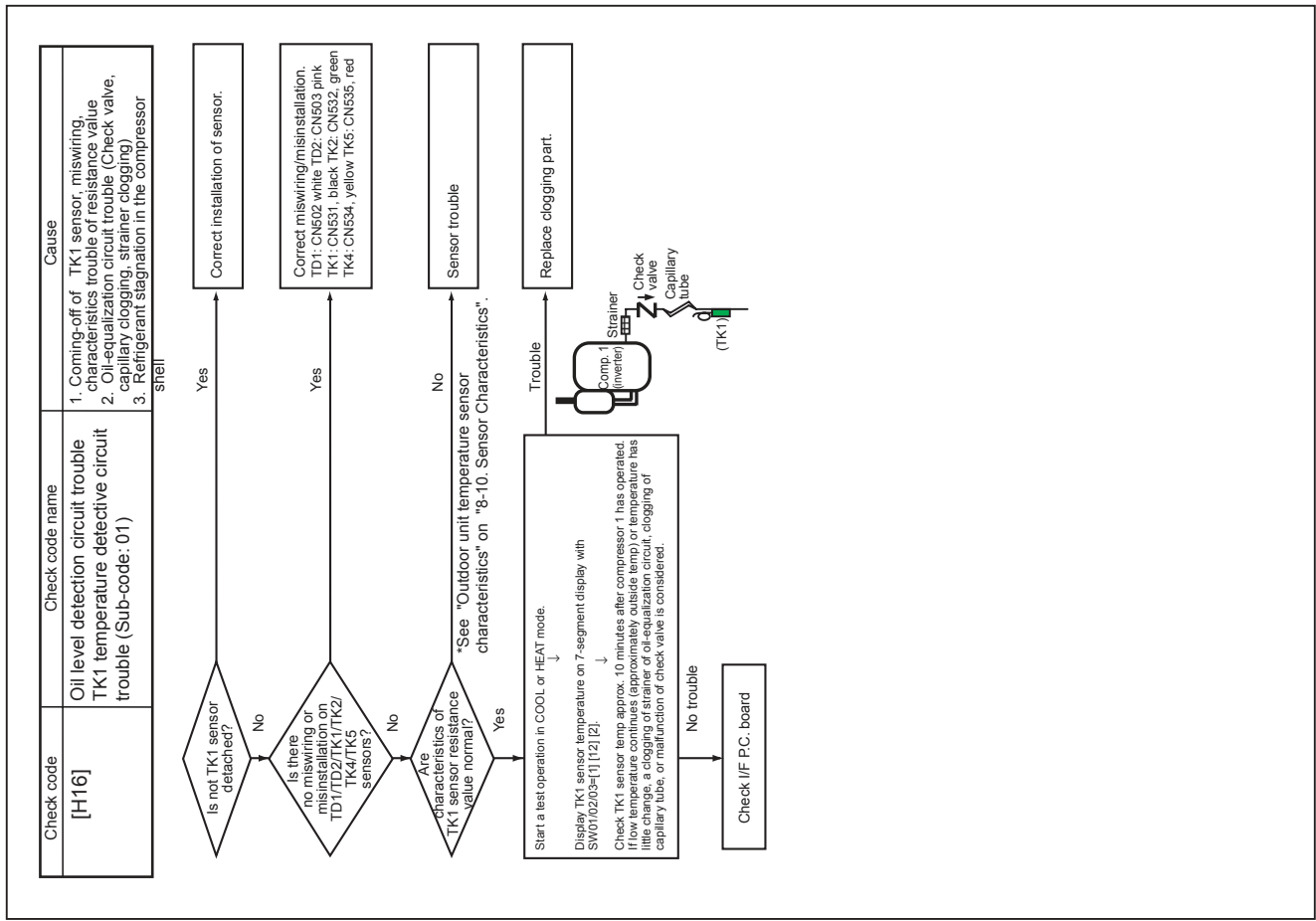

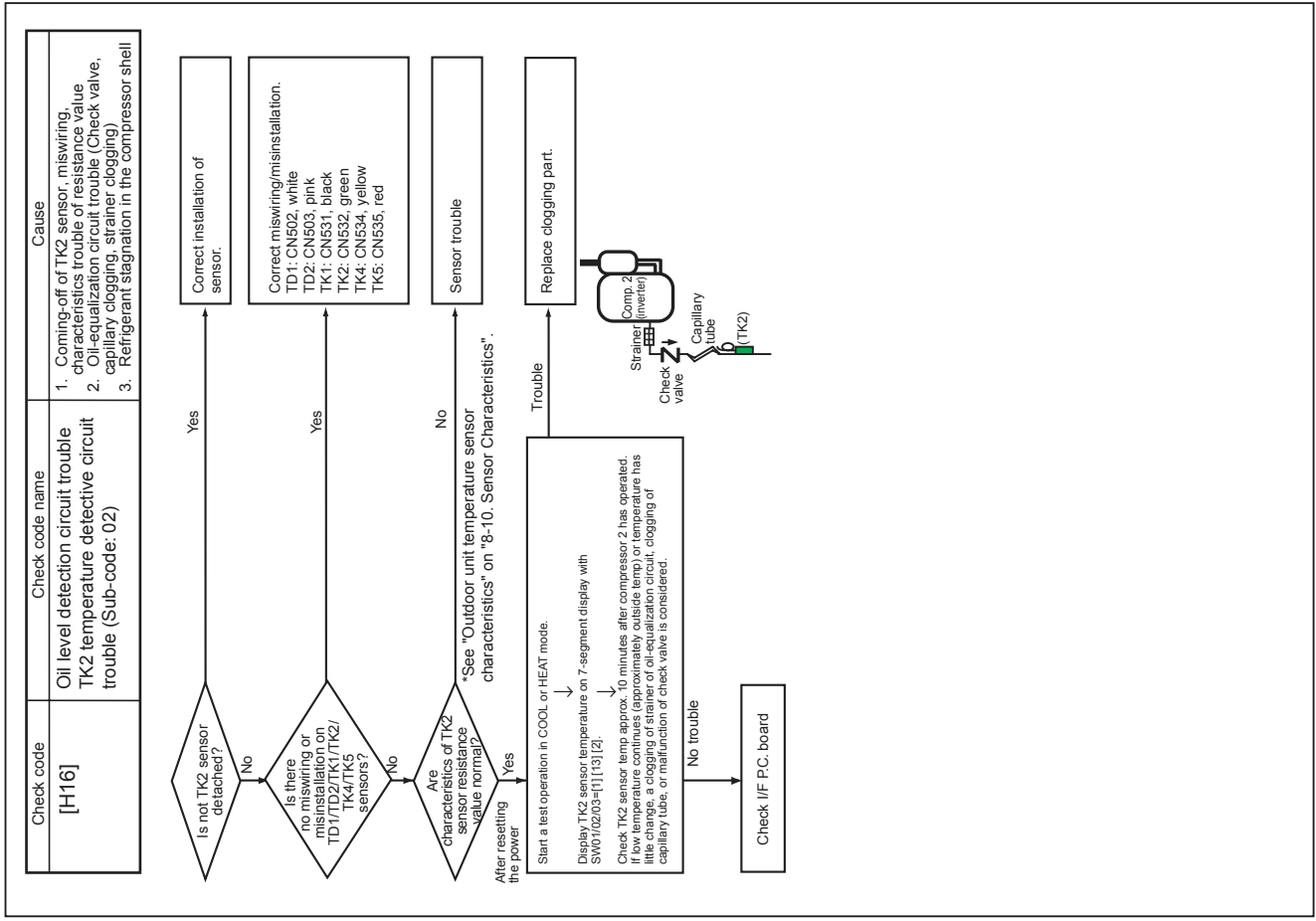
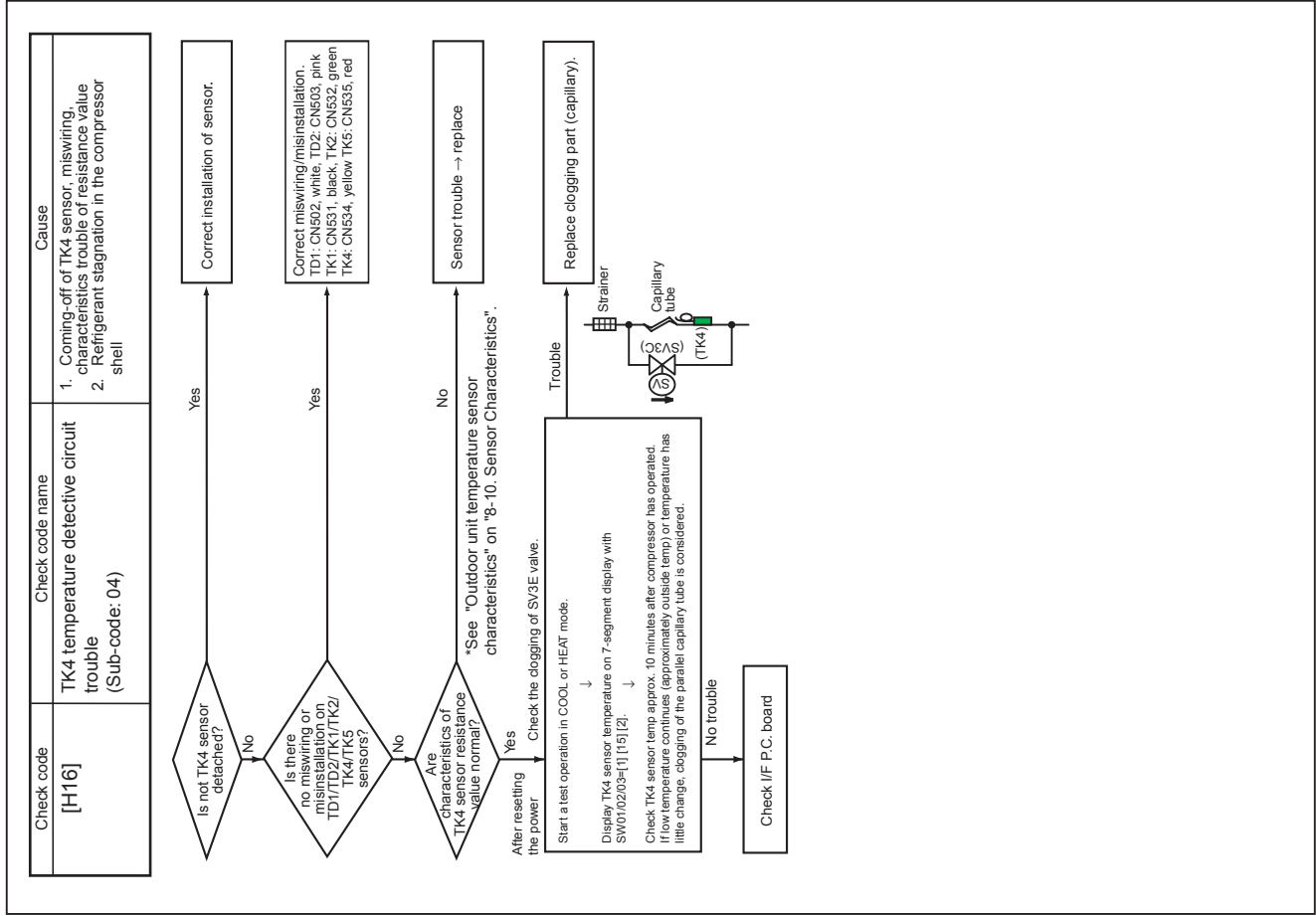

Check code	Check code name	Cause
[J03]	Duplication of Flow Selector units	1. More than one Flow Selector units have been set up in one refrigerant line.

The check code is detected when there are multiple P.C. boards of the Flow Selector unit in one system of the communication line(A/B).

Check code	Check code name	Cause
[J10]	Flow Selector unit overflow trouble	1. Float switch operates. 2. Clogging of drain pipe 3. Flow Selector unit P.C. board trouble

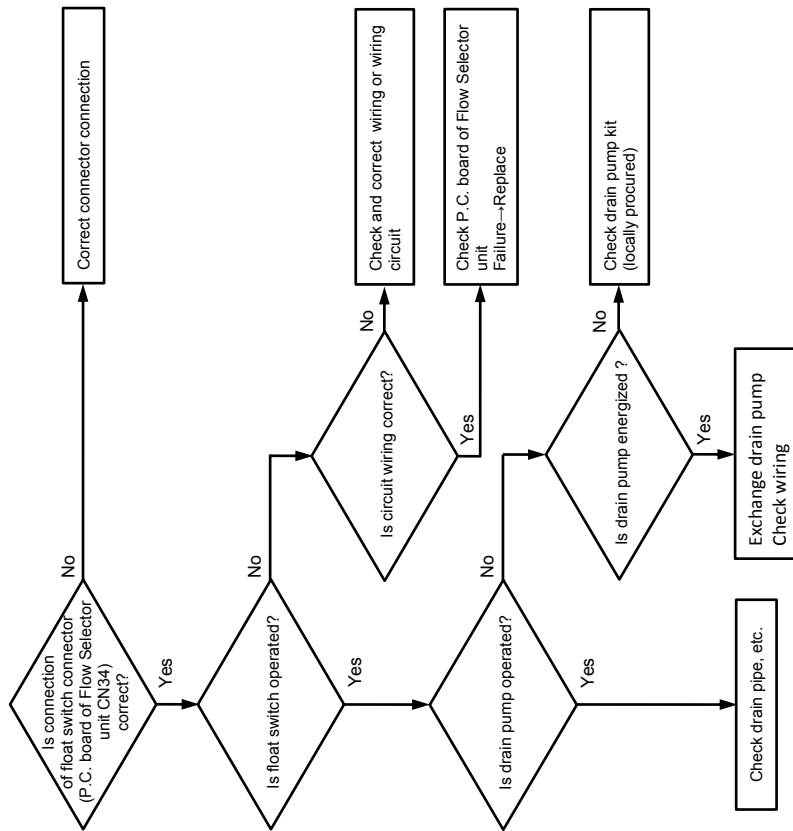

This check code means detection of Open/Short of TCS sensor. Check disconnection of circuit for connection of connector (TCS sensor: CN101, WHI) and characteristics of sensor resistance valve. (See "Indoor unit temperature sensor characteristics" on "8-10. Sensor Characteristics".) If sensor is normal, replace flow selector P.C. board.

Check code	Check code name	Cause
[J11]	Flow Selector unit Temperature sensor(TCS) trouble	TCS sensor Open/Short

This is the Open/Short detection of the TCS sensor. Check the disconnection of the connector connection (TCS sensor: CN101) circuit and the resistance value characteristics of the sensor. (Refer to the 8.10 sensor characteristics: Temperature sensor characteristics of the Flow Selector unit.) When the sensor is normal, exchange the I/F P.C. board of the outdoor.

This check code means detection of Open/Short of TCS sensor. Check disconnection of circuit for connection of connector (TCS sensor: CN101, WHI) and characteristics of sensor resistance value. (See "Indoor unit temperature sensor characteristics" on "8-10. Sensor Characteristics".) If sensor is normal, replace flow selector P.C. board.

Check code	Check code name	Cause
[H16]	TK5 temperature defective circuit trouble (Sub-code: 05)	1. Coming-off of TK5 sensor, miswiring, characteristics trouble of resistance value 2. Refrigerant stagnation in the compressor shell

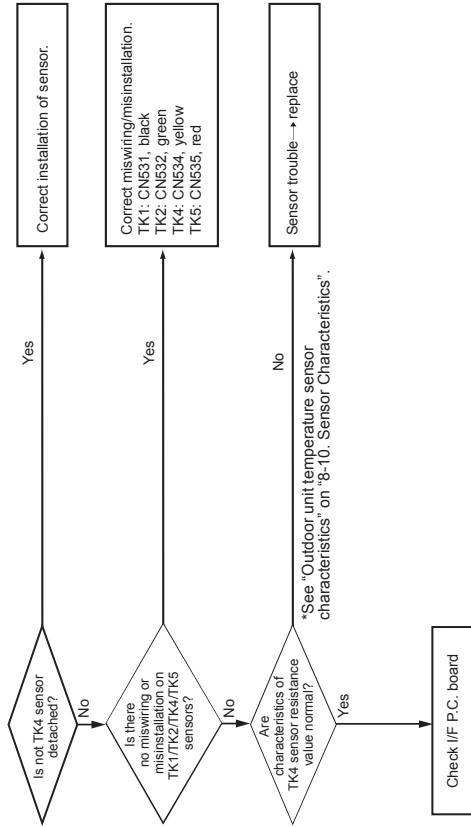

Check code [L05]	Check code name Duplicated indoor units with priority (Displayed on indoor unit with priority)	Cause Two or more prior indoor units exist.
---------------------	--	--

This check code is displayed on the indoor unit set as a prior one when two or more prior indoor units are detected.
 • Priority setup with two or more units is not available. As only one indoor unit with priority is valid, change the setup.

Check code [L06]	Check code name Duplicated indoor units with priority (Displayed on the indoor units other than ones with priority and on the outdoor unit)	Cause Two or more indoor units with priority are duplicated.
---------------------	---	---

Sub-code: amount of indoor units with priority

When priority is given to two or more indoor units, this check code is displayed on indoor units other than the units set as prior ones and the outdoor unit.
 • As only one indoor unit with priority is valid, change the setup.

Check code [L07]	Check code name A group line exists in an individual indoor unit	Cause A group line is connected to an individual indoor unit.
---------------------	---	--

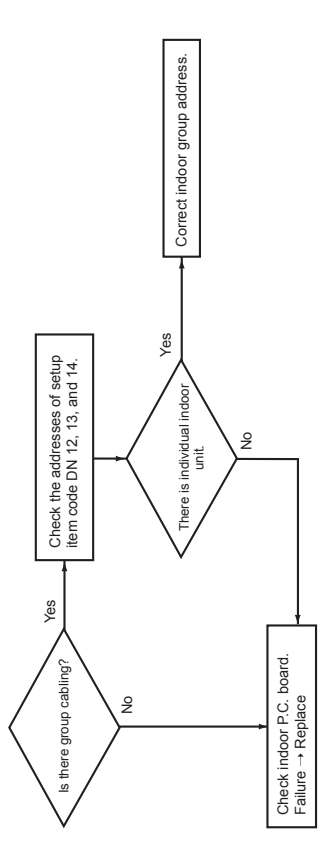

Check code [L02]	Check code name Outdoor units model disagreed trouble	Cause When the indoor unit that does not correspond is connected with the outdoor unit
---------------------	--	---

Check code [L03]	Check code name Duplicated indoor header units	Cause There are two or more indoor header units in a group during group control.
---------------------	---	---

1) Check whether the connection on remote controllers (group and/or individual) has been changed since the group configuration and address checking on the remote controllers finished.
 2) If the group configuration and address are normal when power has been turned on, the mode automatically shifts to address setup mode. For setting up addresses again, refer to "Address setup".

Check code [L04]	Check code name Duplicated setup of outdoor line address	Cause Outdoor line addresses are duplicated.
---------------------	---	---

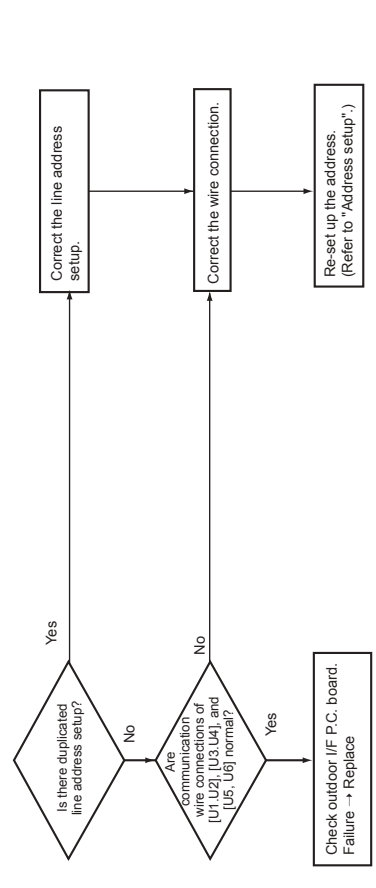

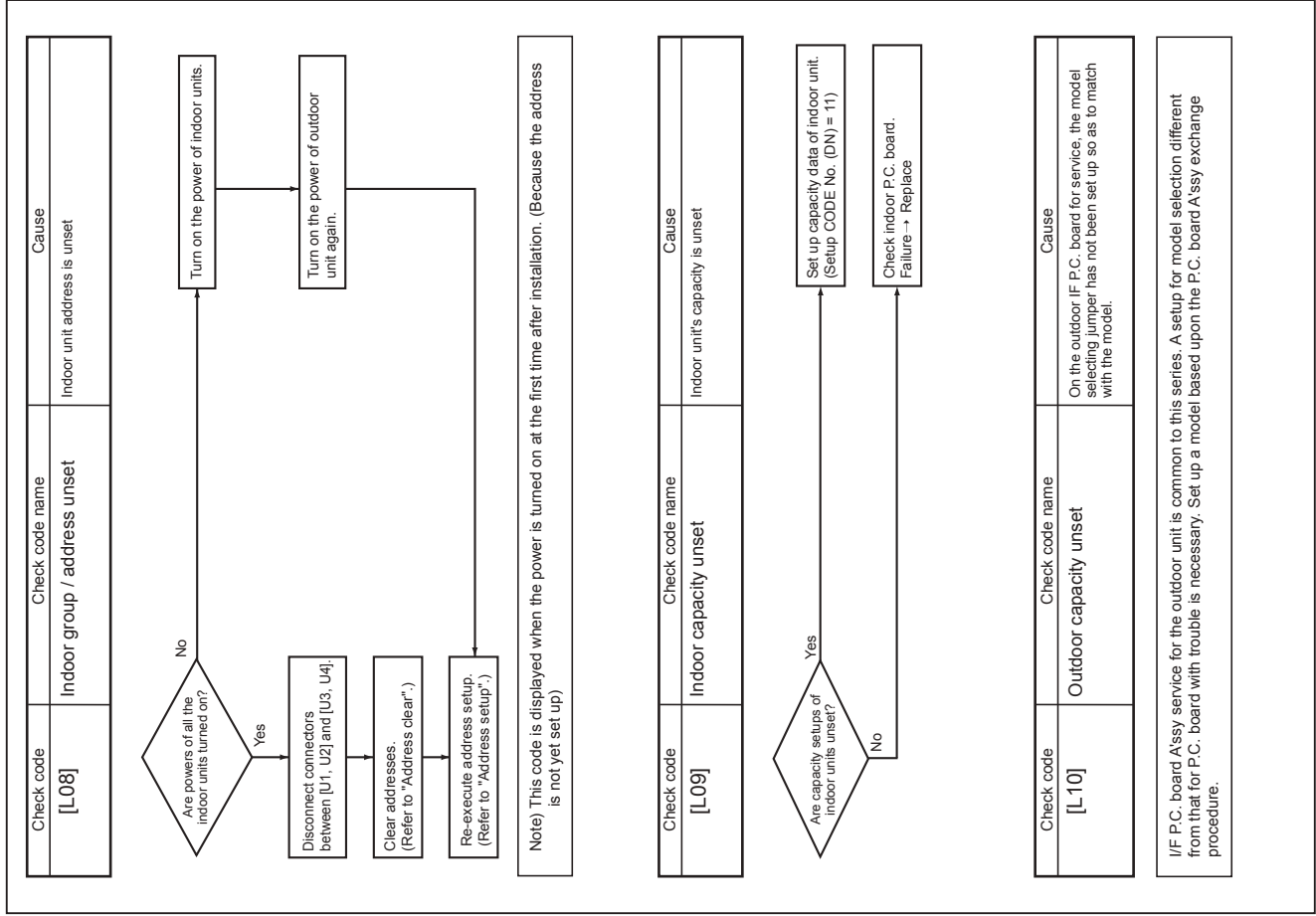
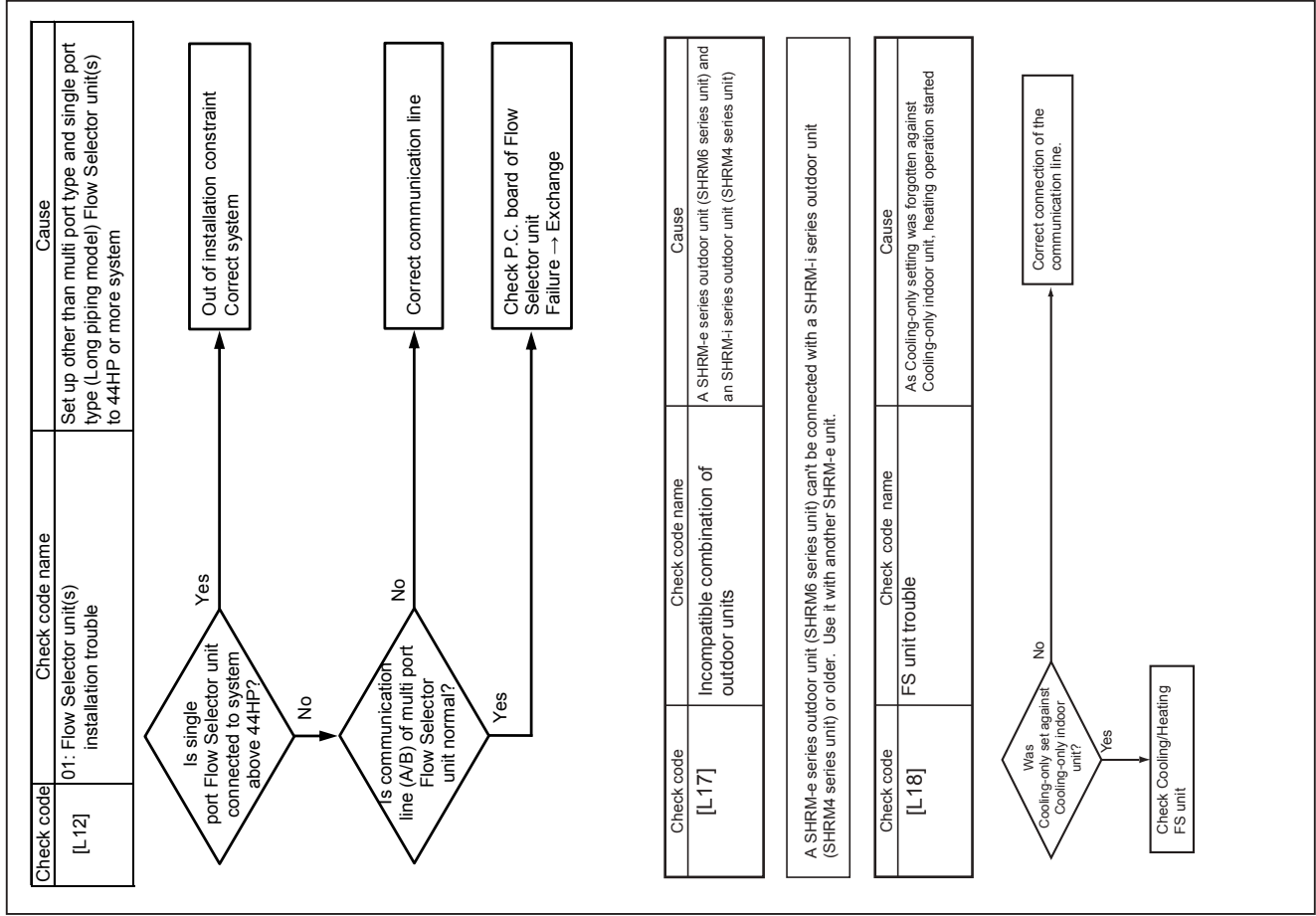

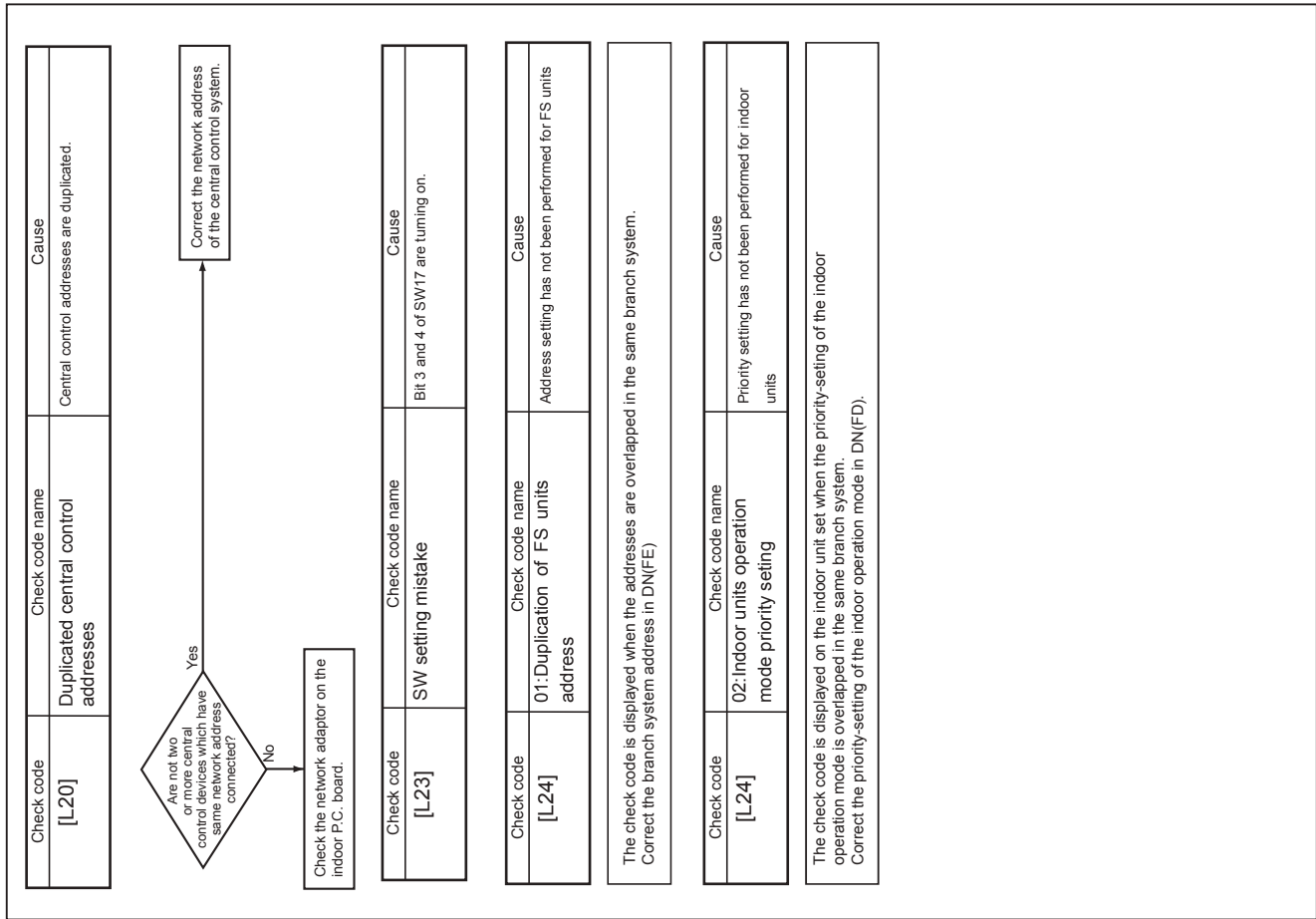
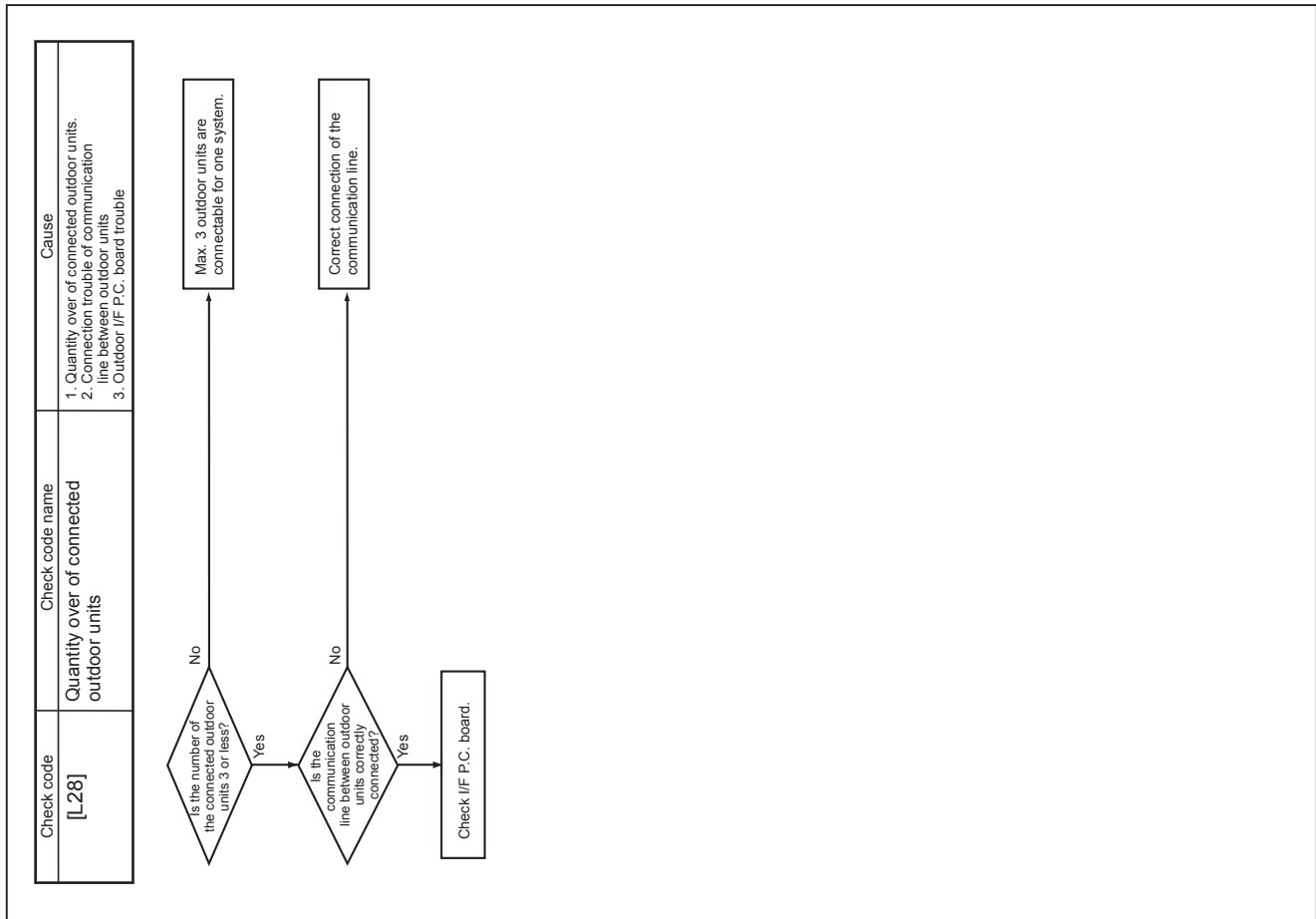

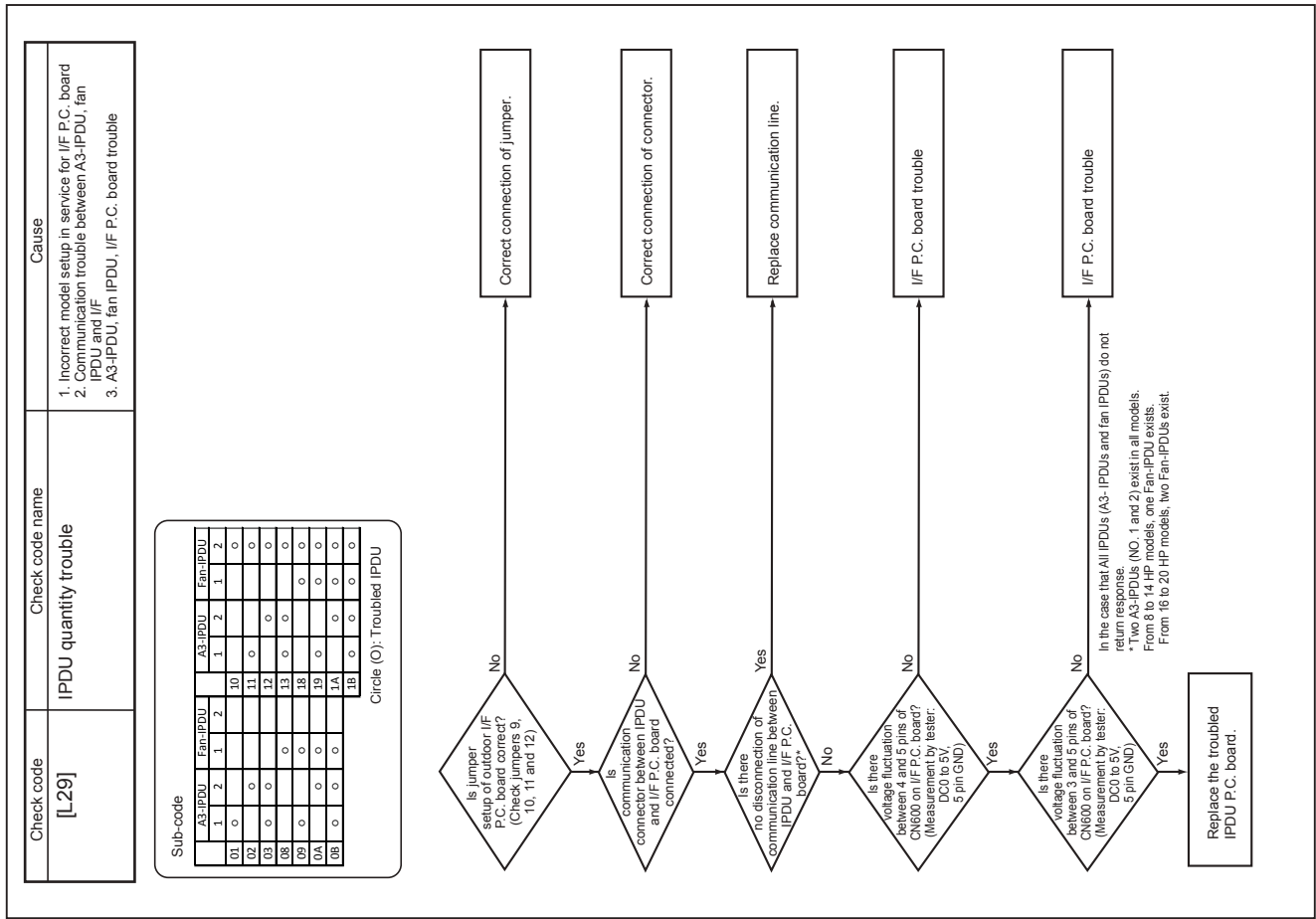
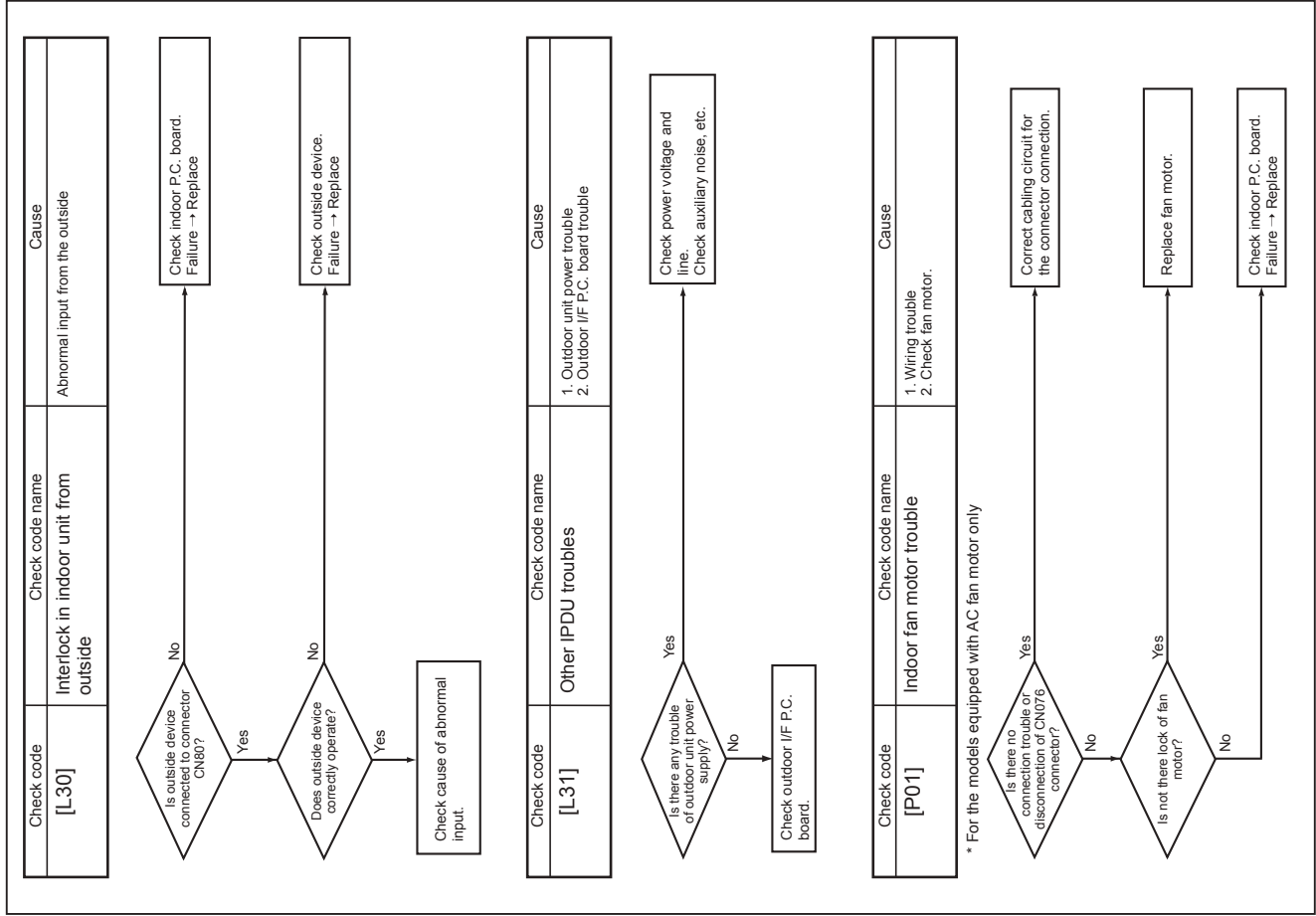

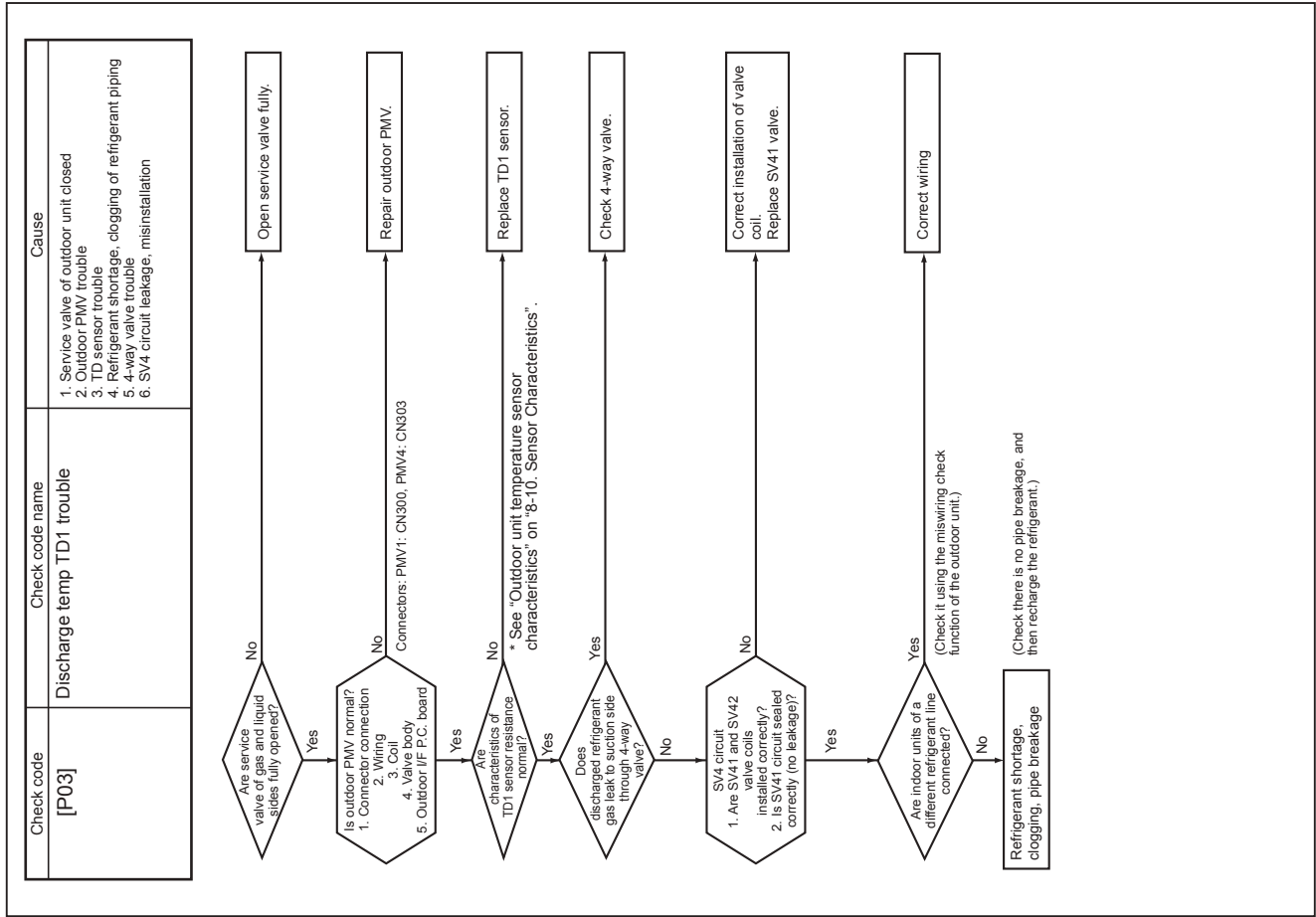
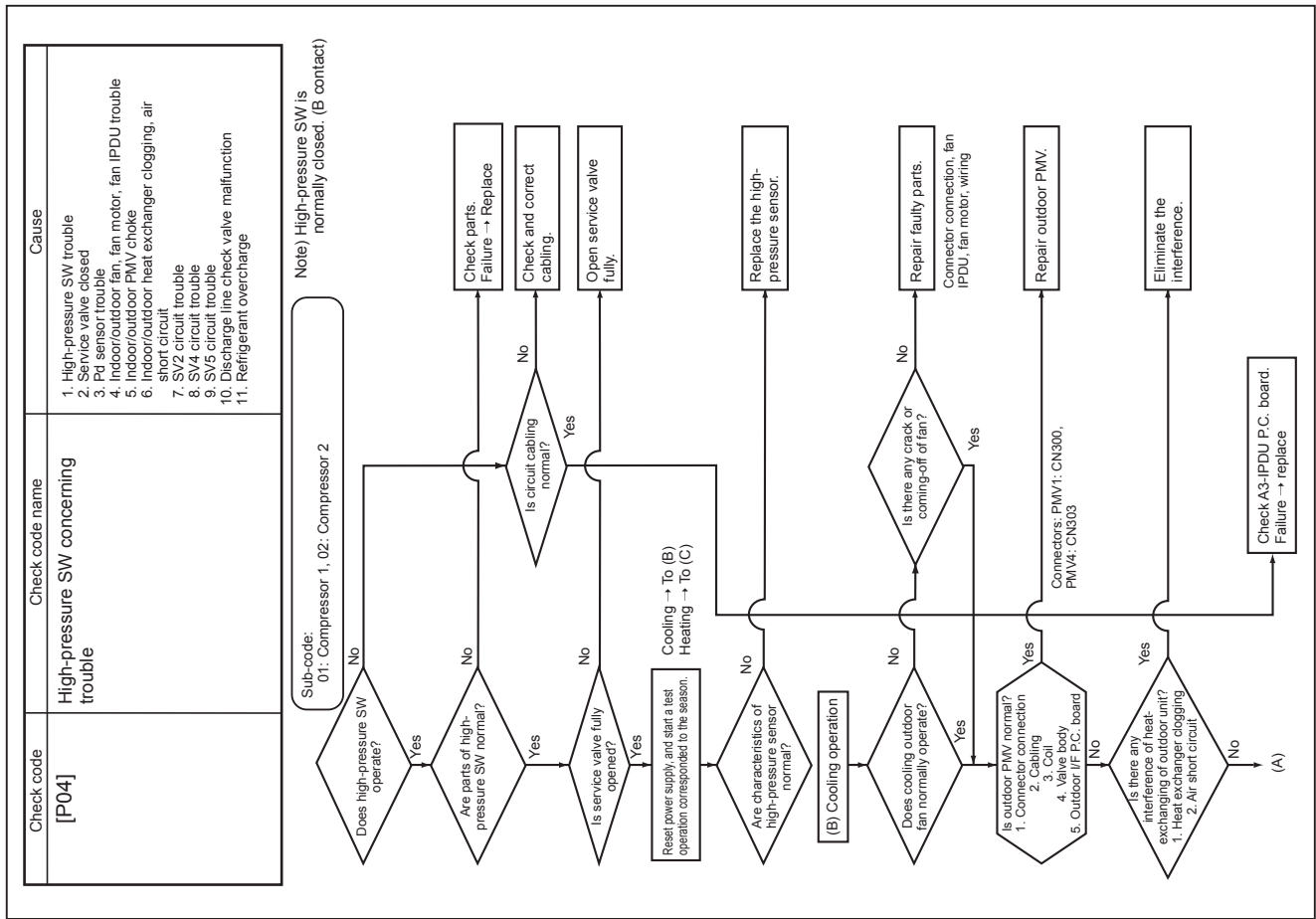

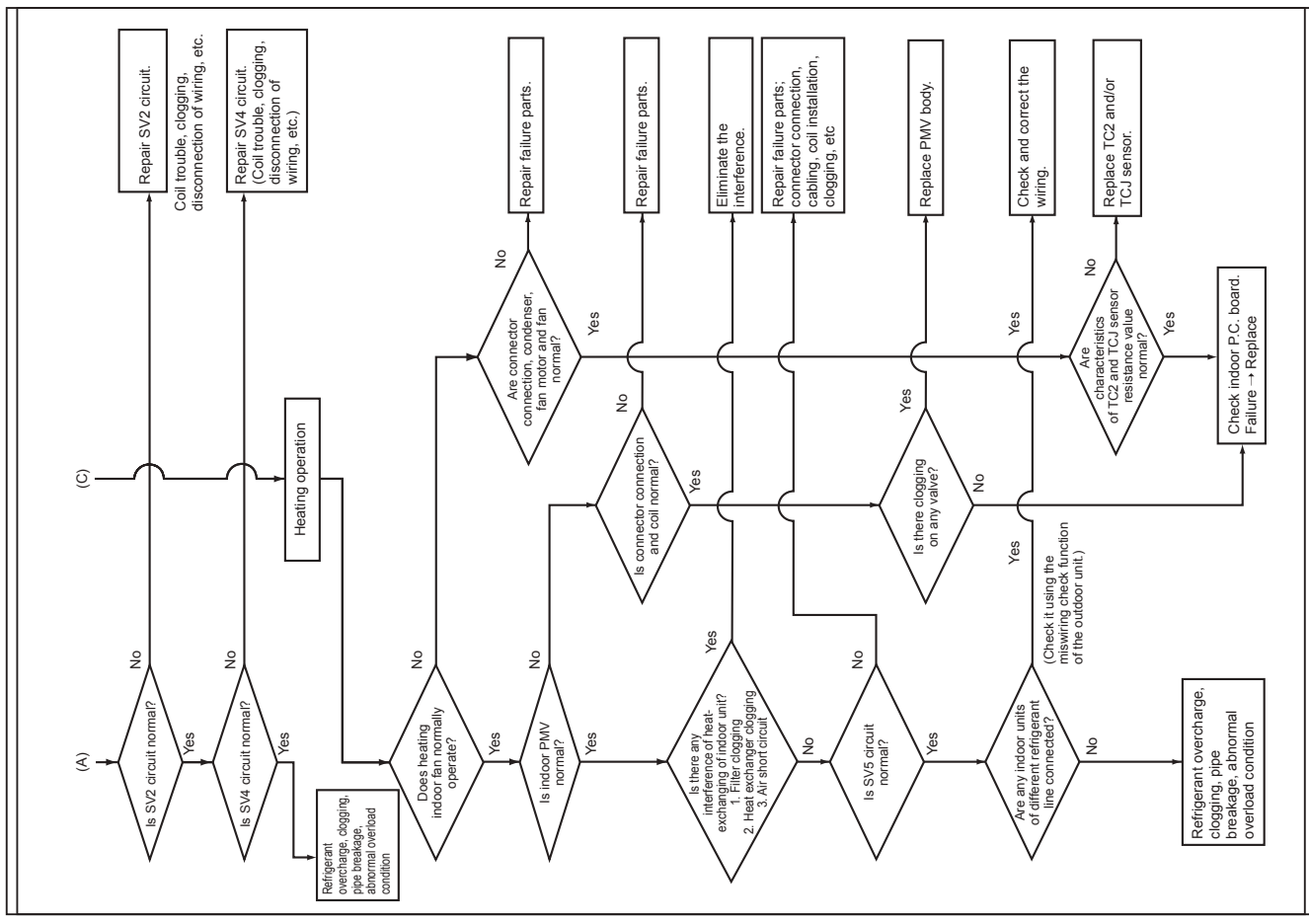
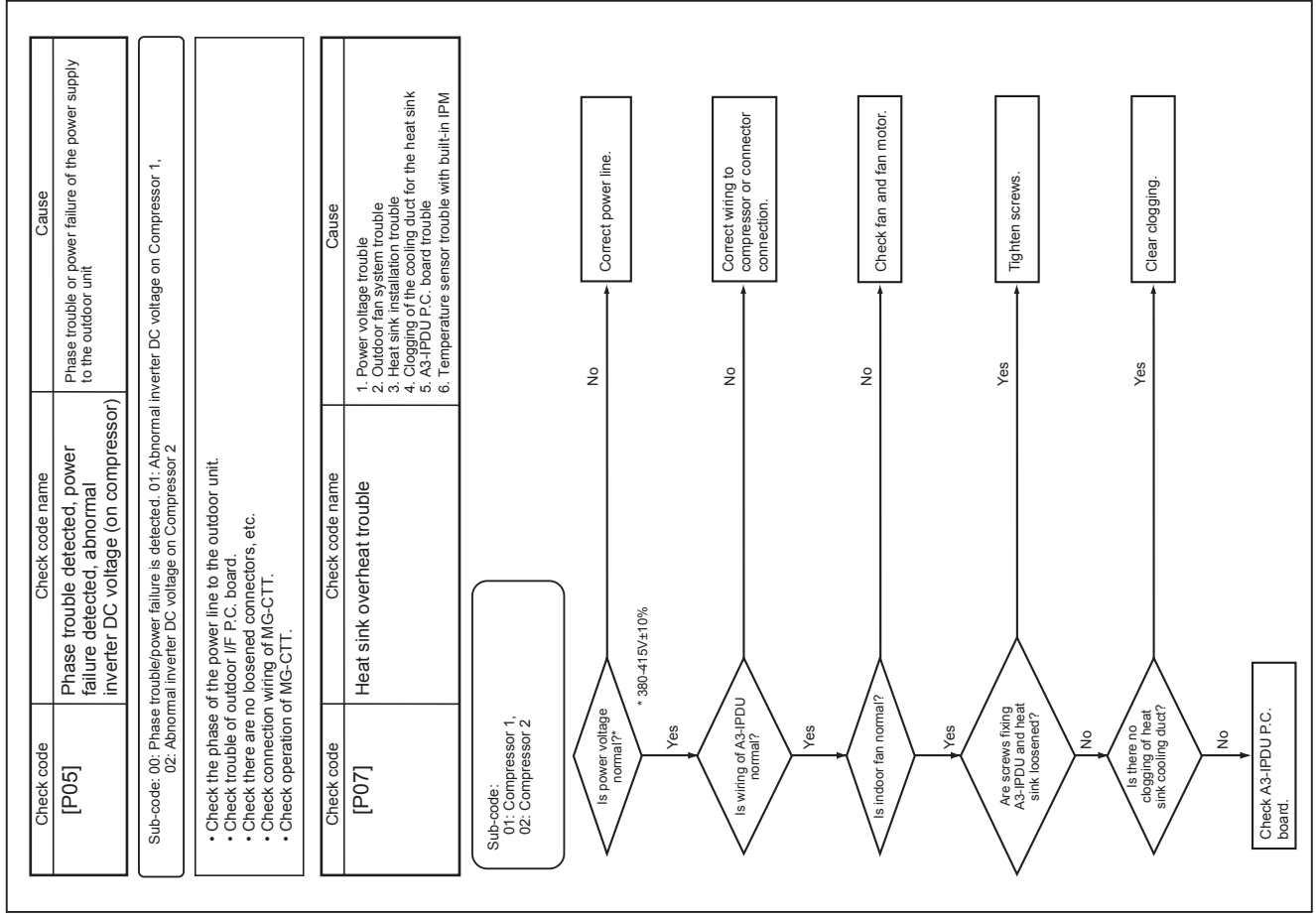

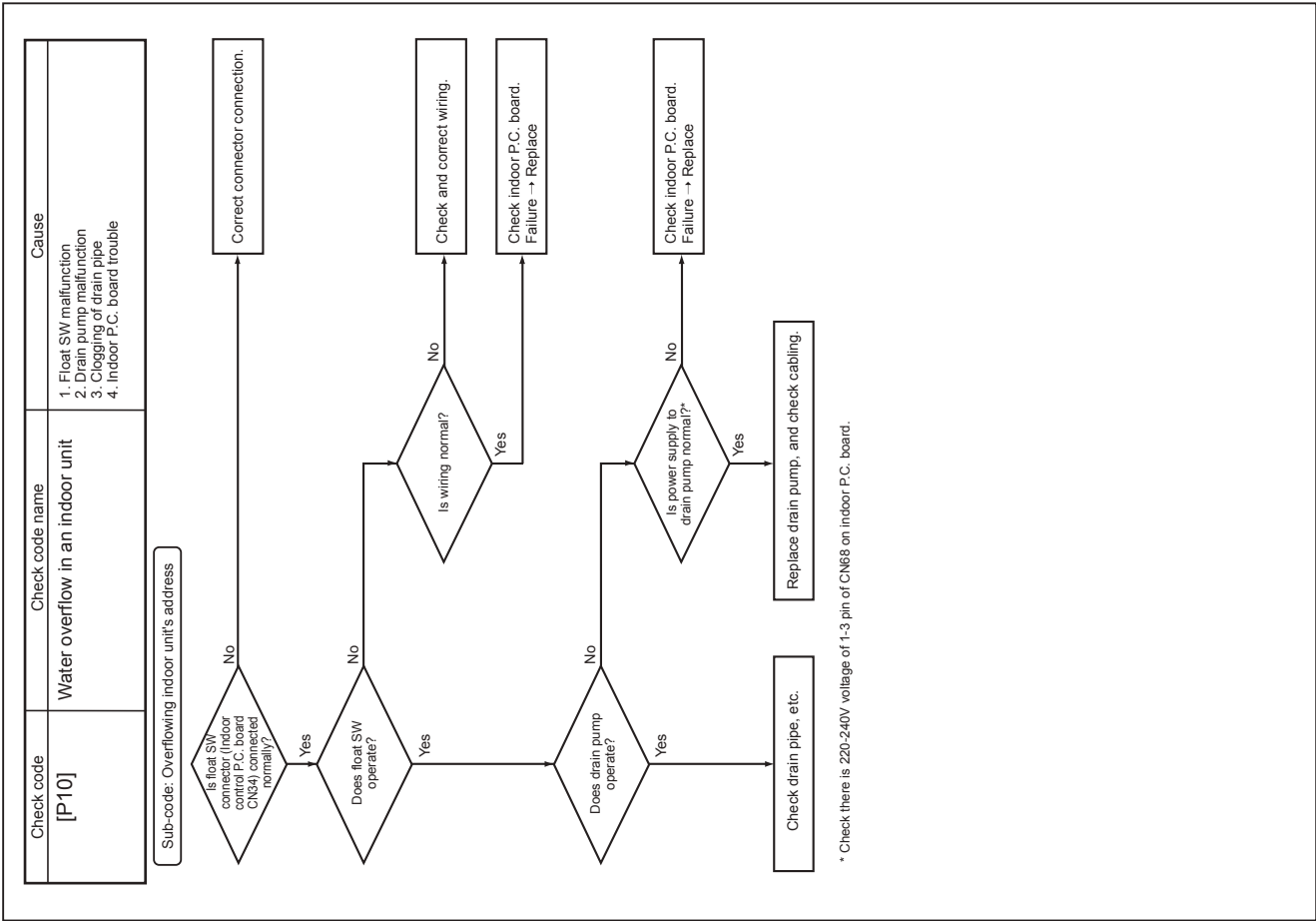
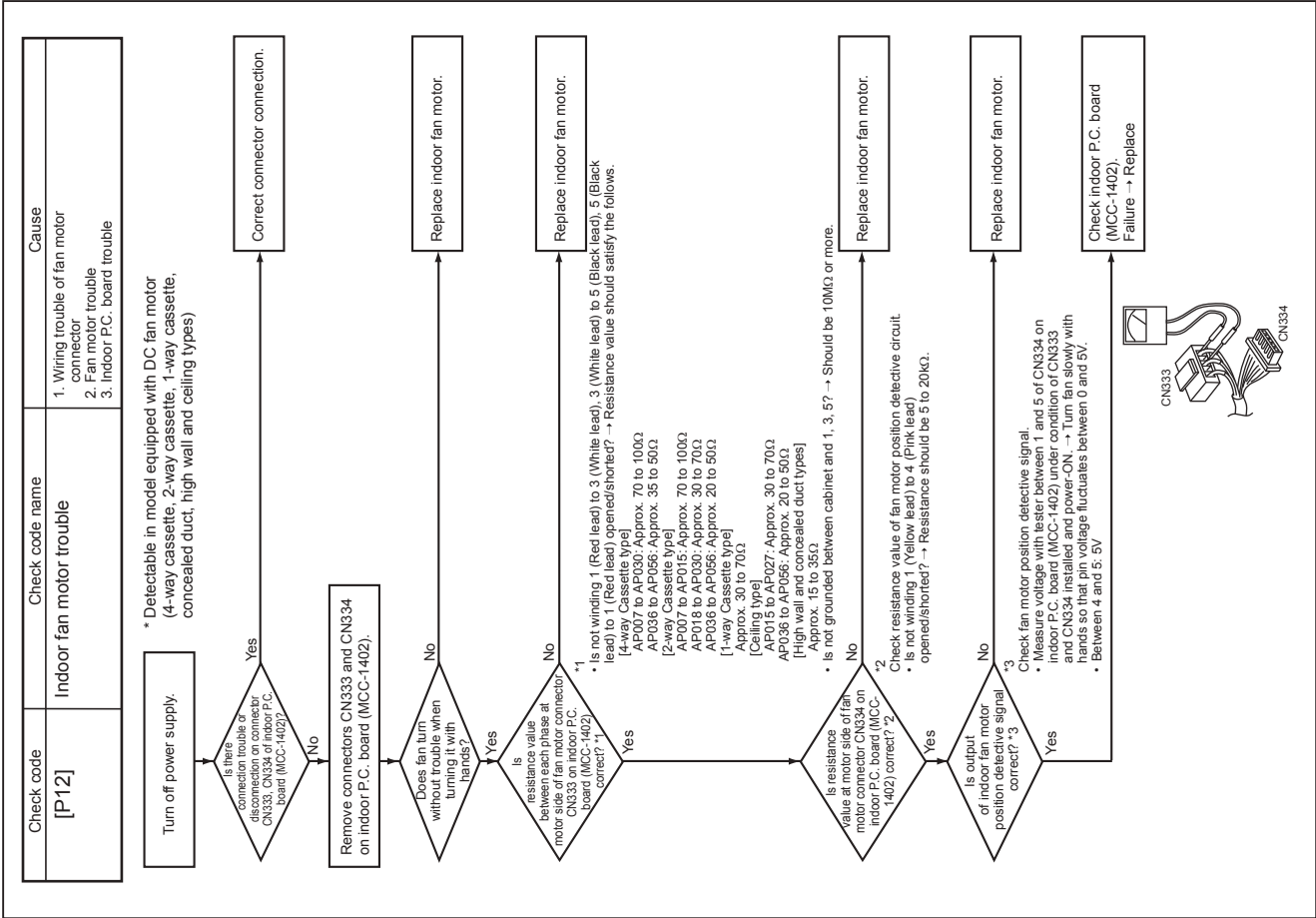

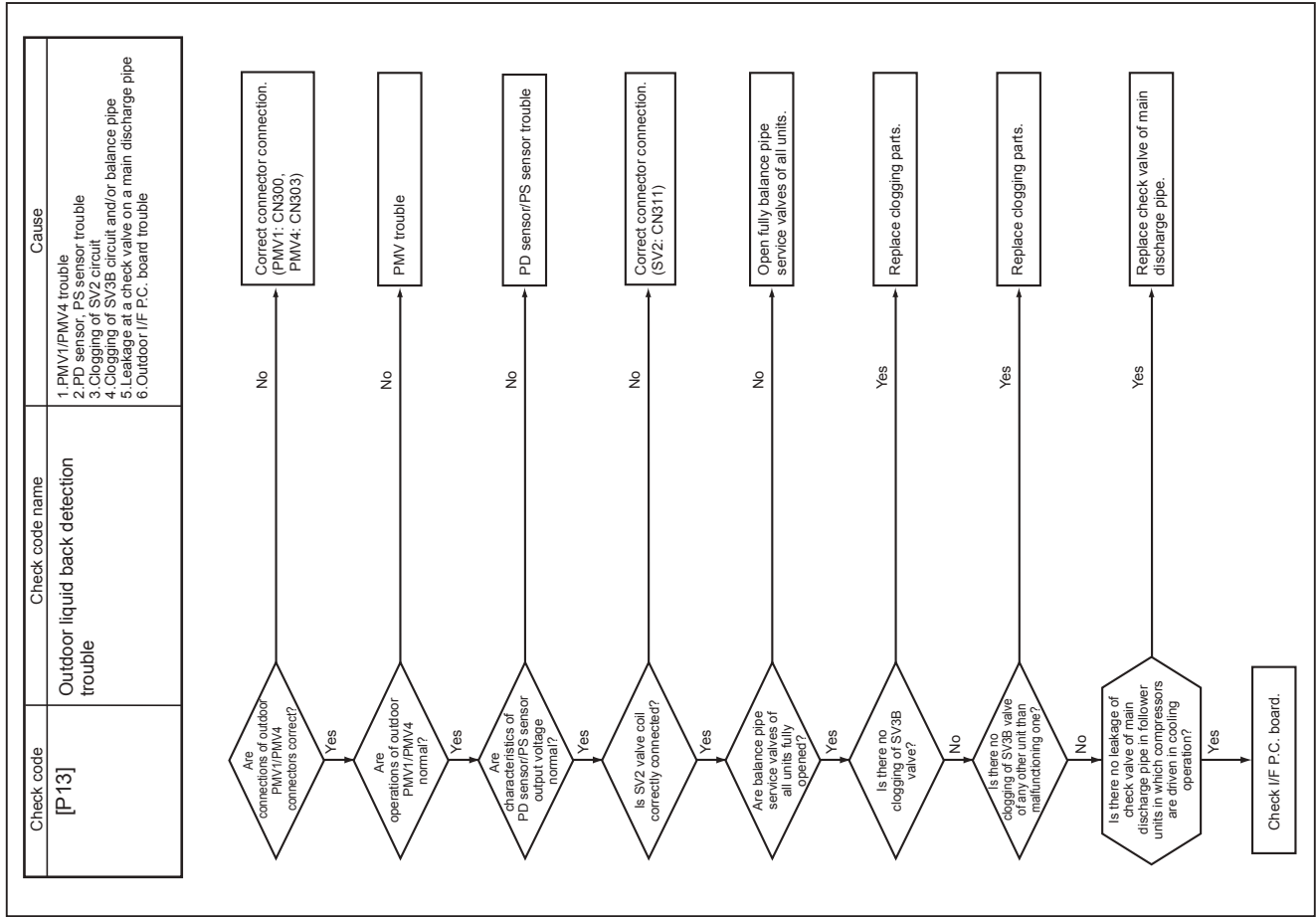
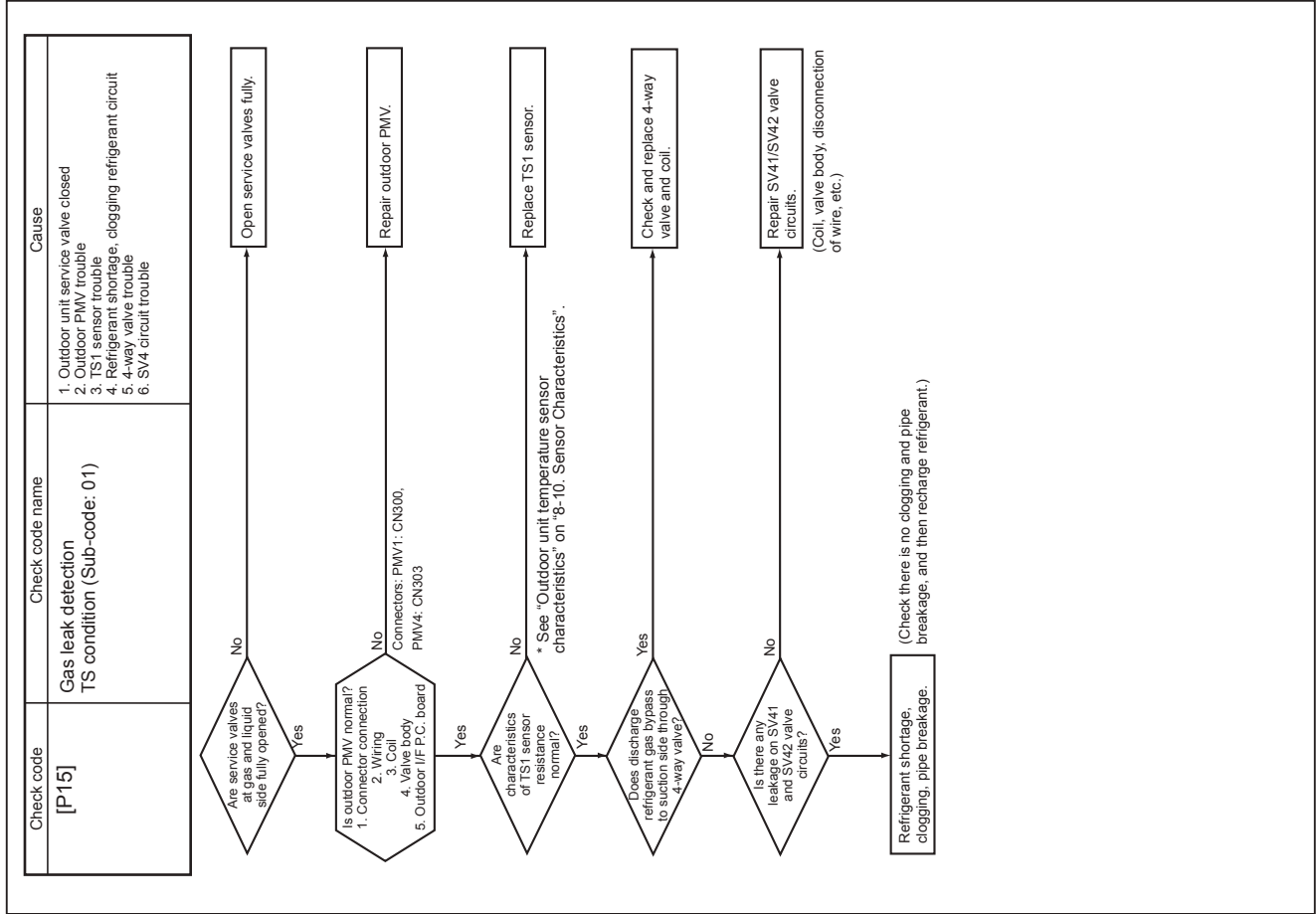

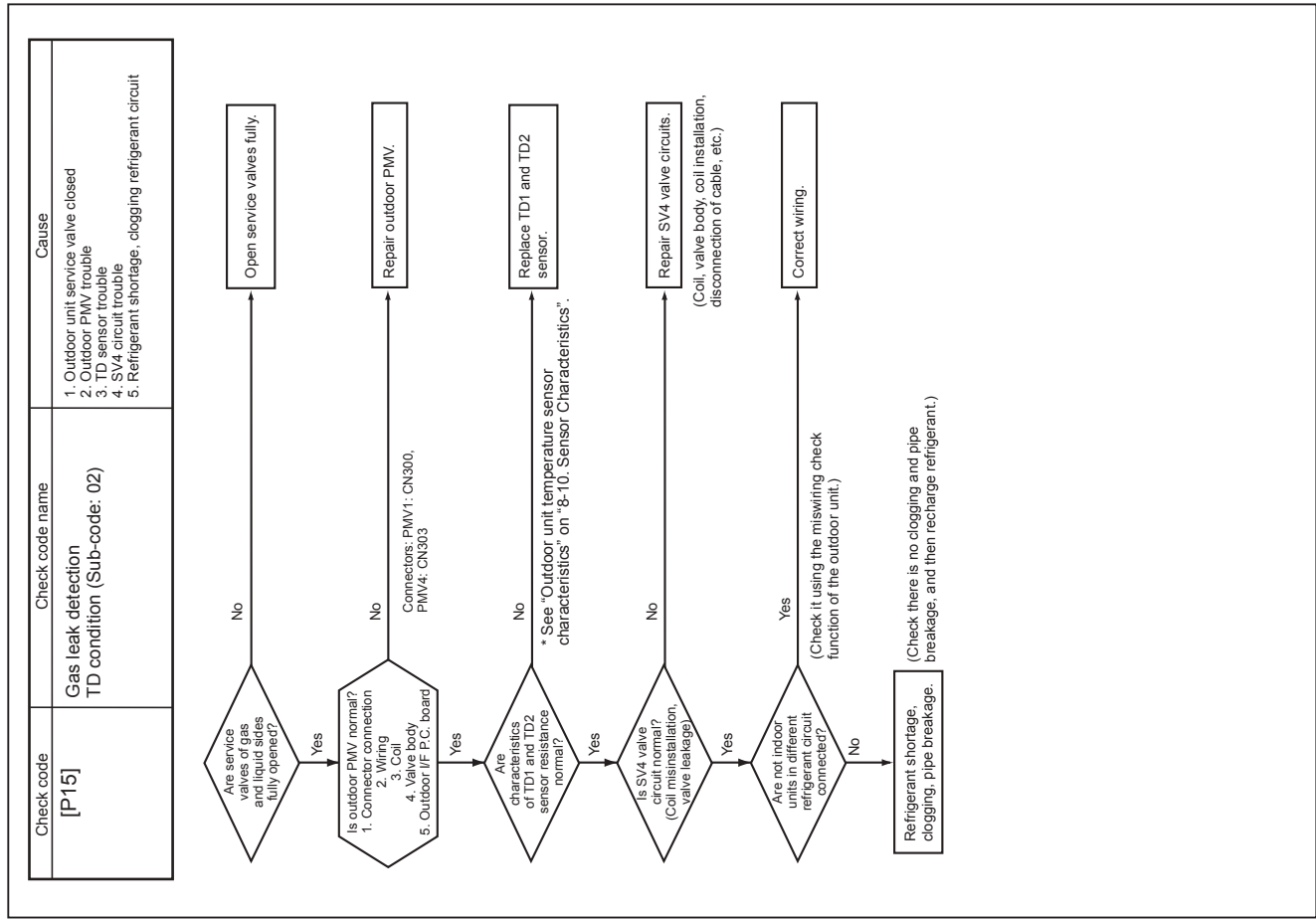
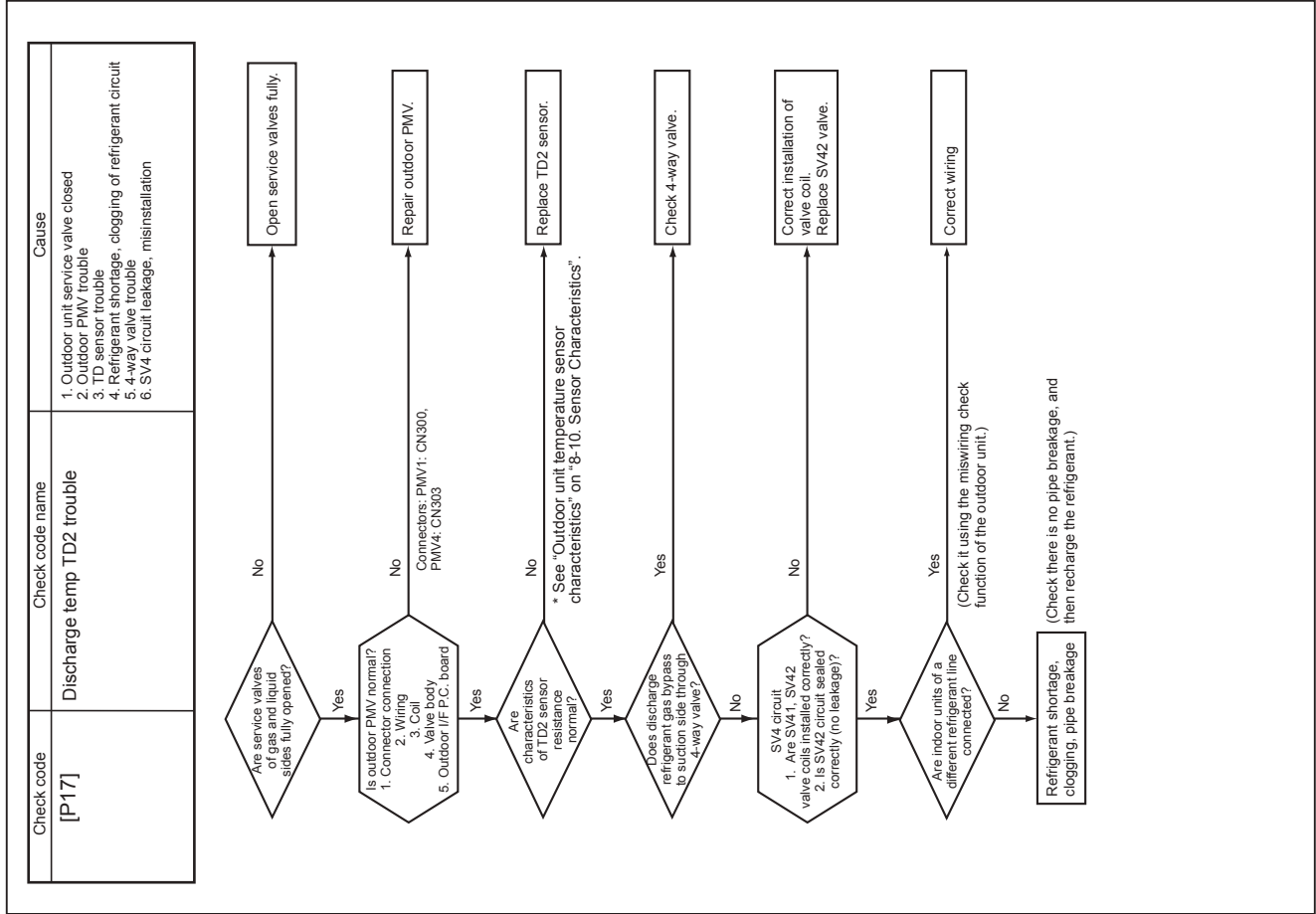

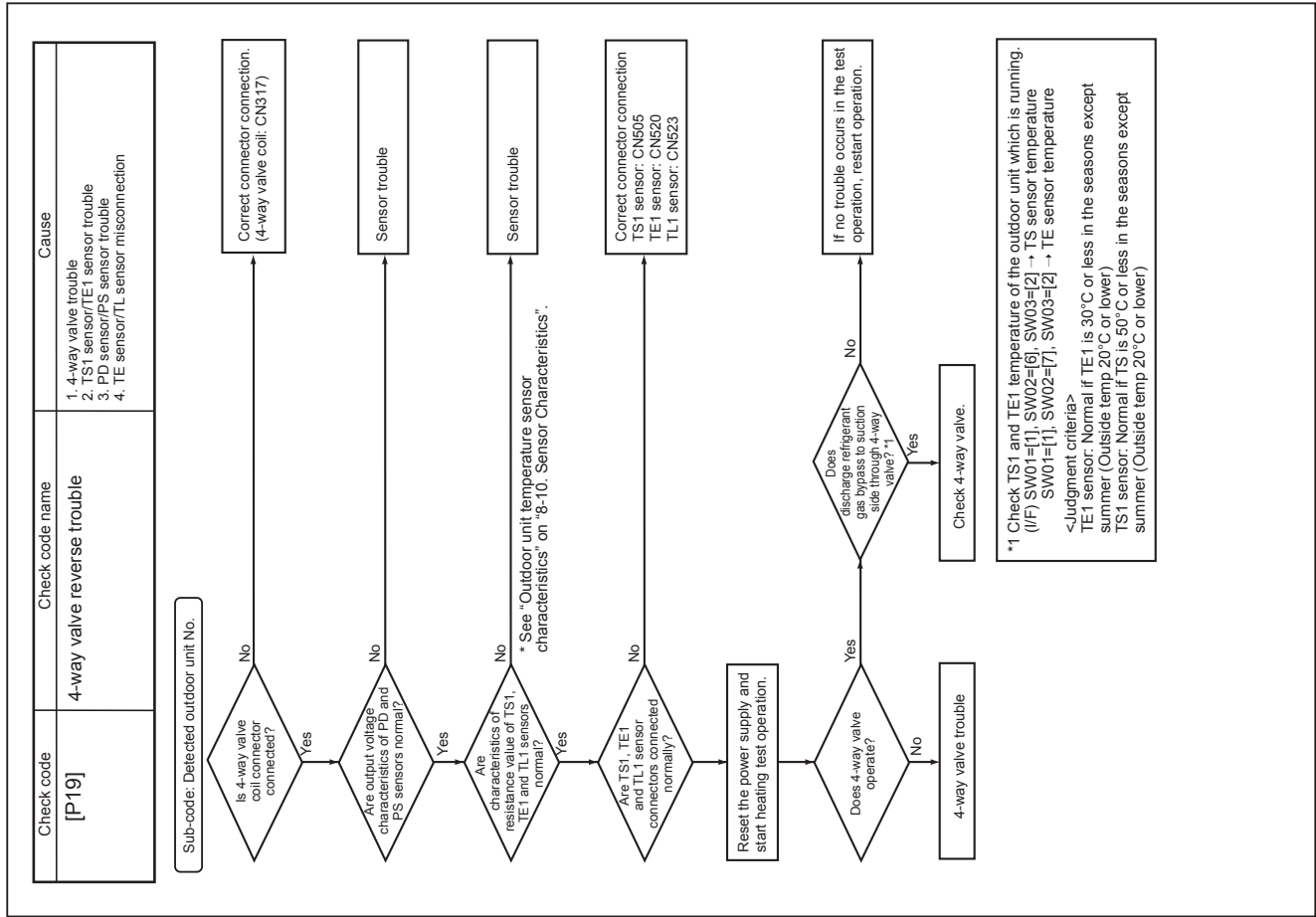
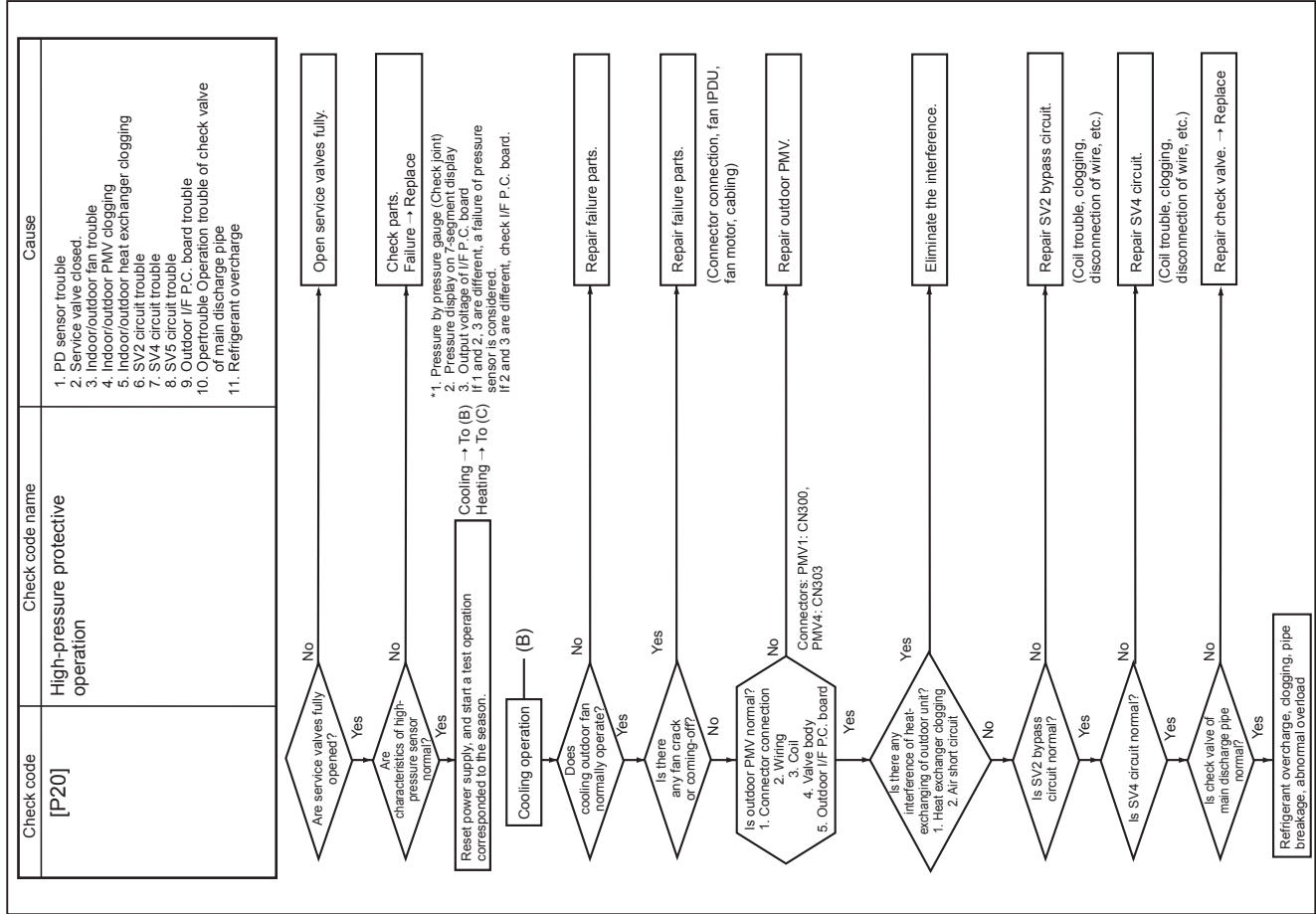

Check code	Check code name	Cause
[P22]	Outdoor fan IPDU trouble	1. Fan lock 2. Fan IPDU P.C. board trouble 3. Overload 4. External cause such as blast

Sub-code:
 *0: IPM short circuit
 *1: Position detection circuit trouble
 *3: Motor lock
 *4: Motor current trouble detected
 *C: TH sensor temperature trouble
 *D: TH sensor trouble
 *E: Fan Vdc trouble
 * : 1:Fan1,2:Fan2

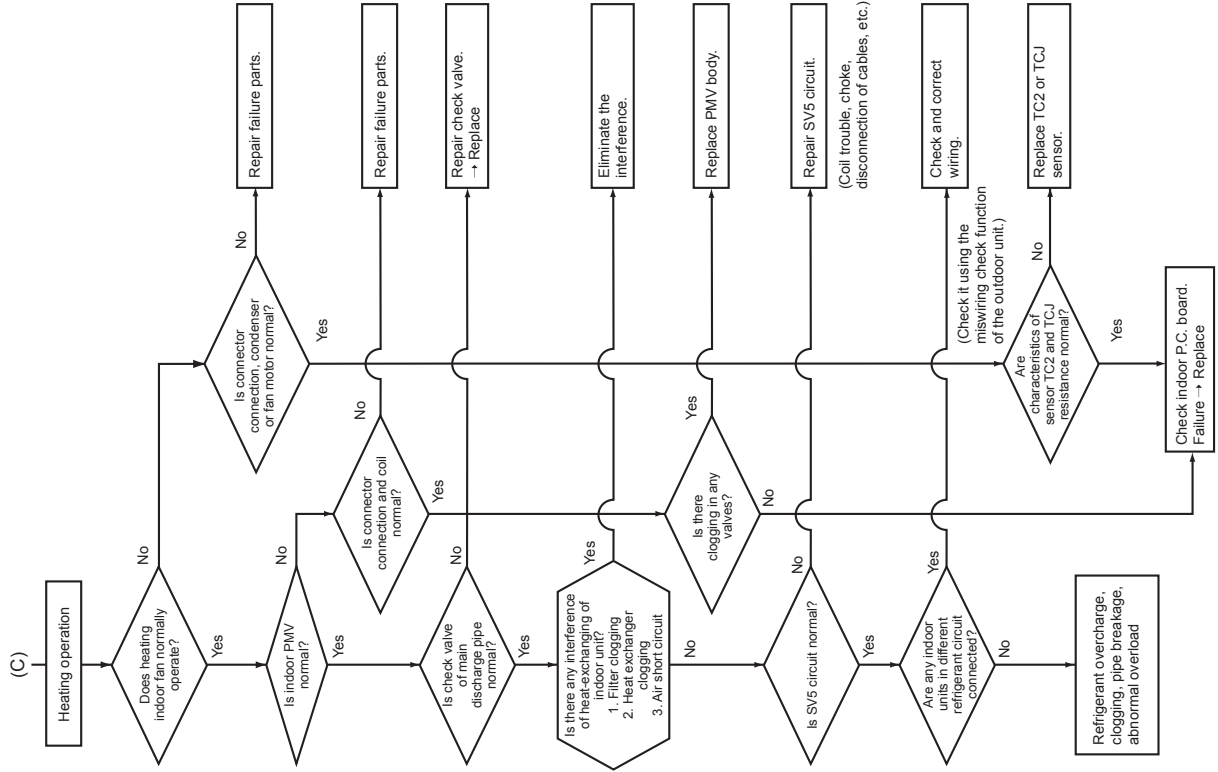
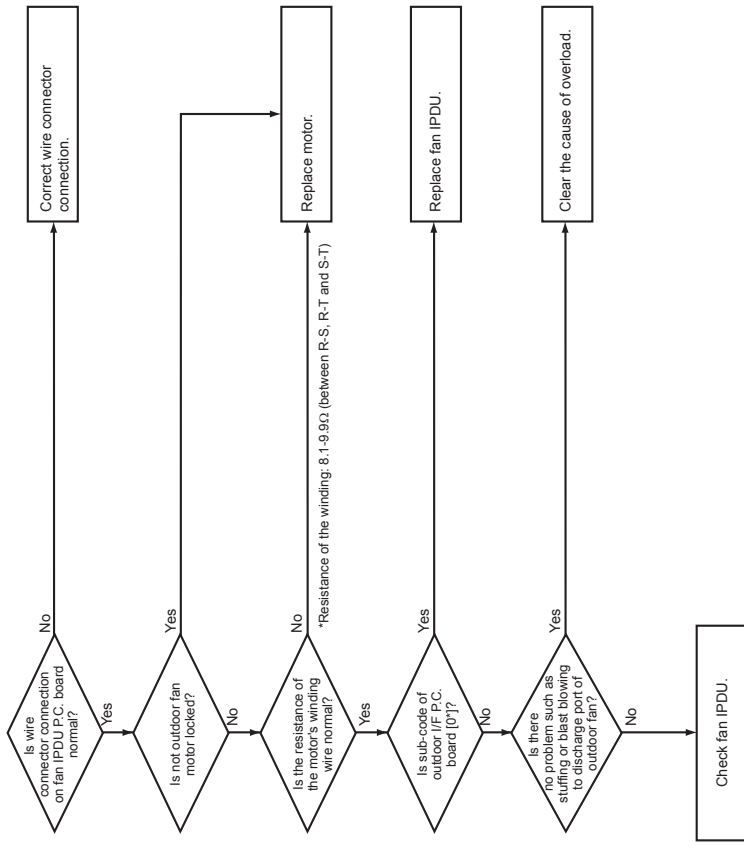

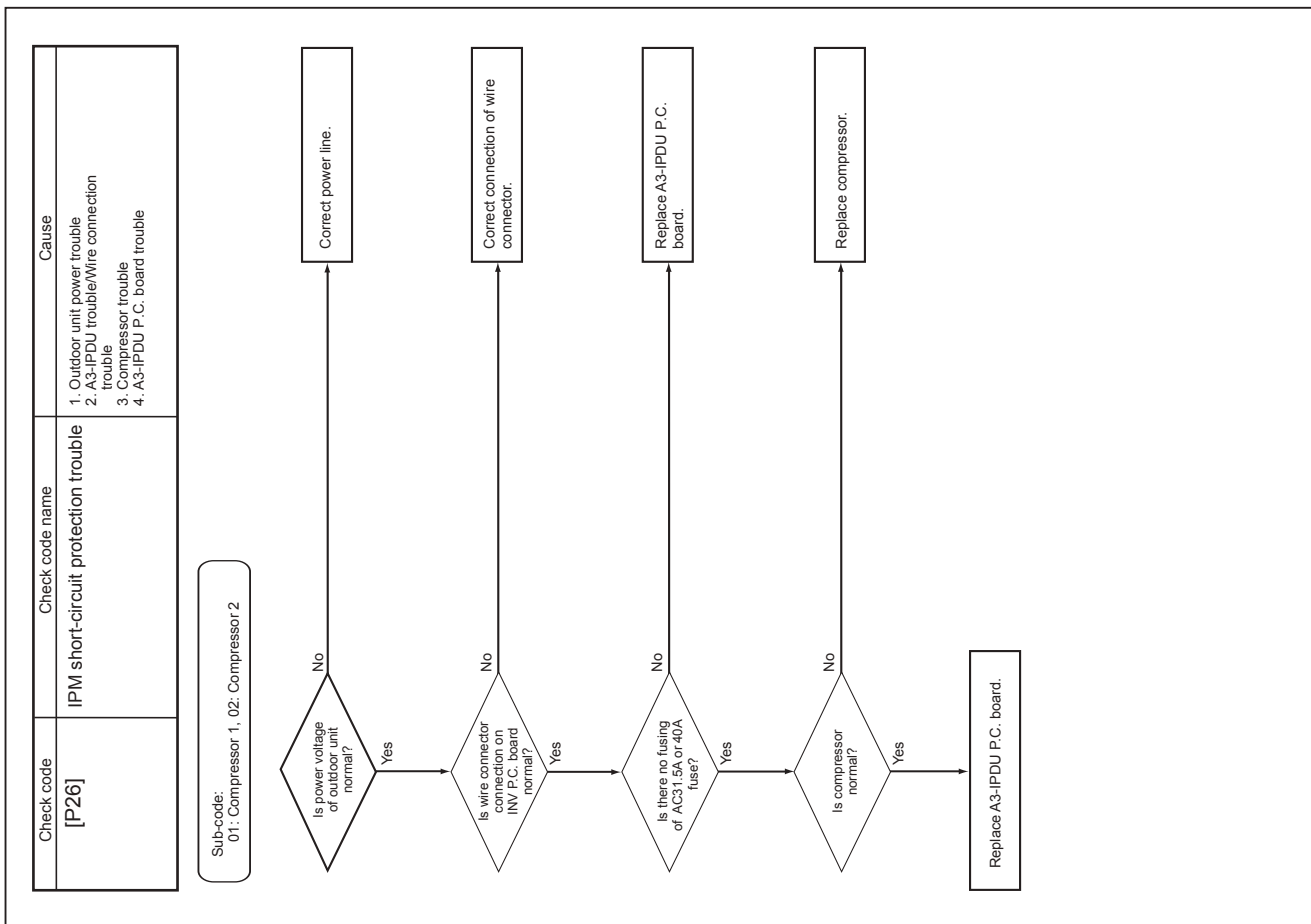
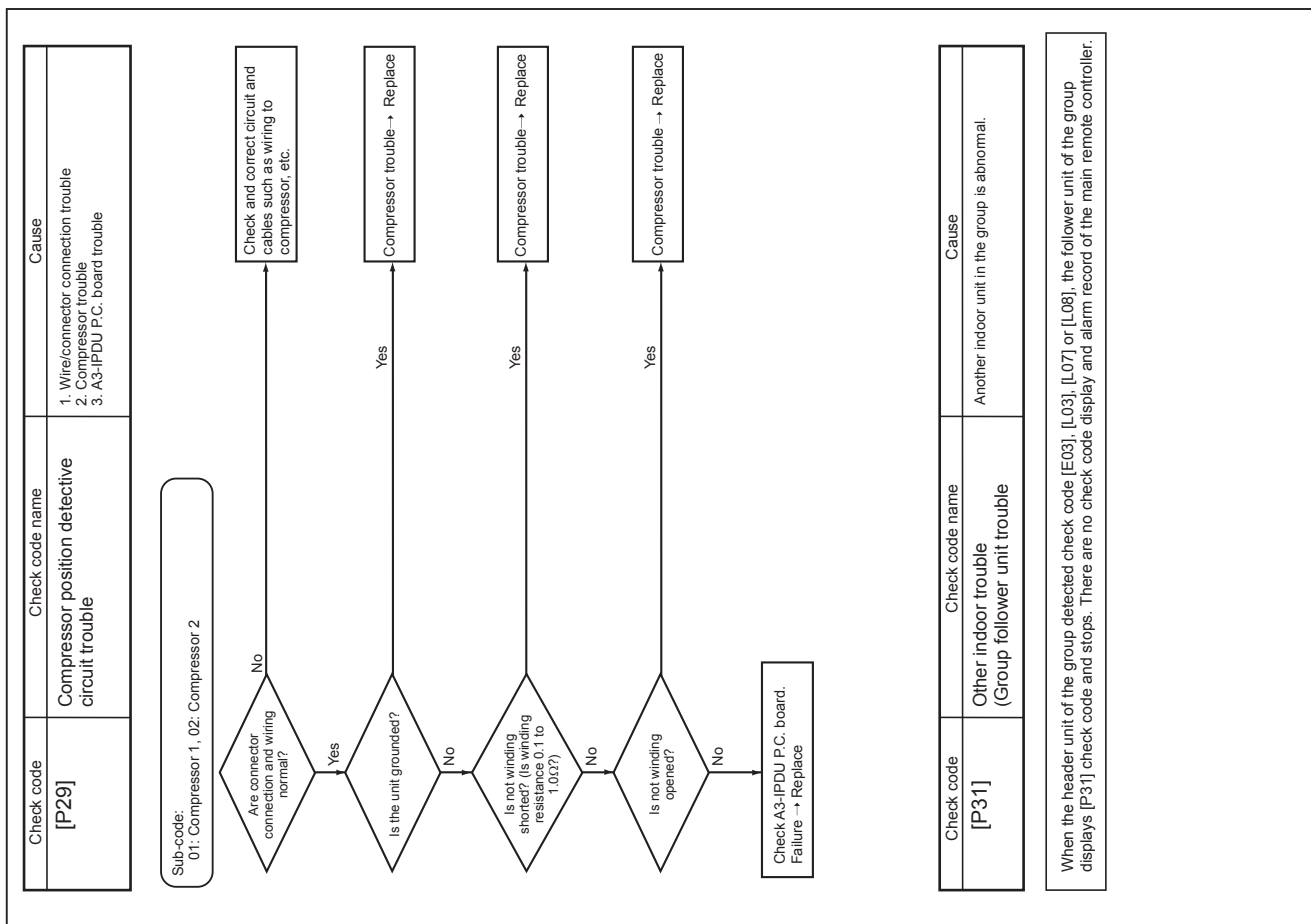

8-6. 7-Segment Display Function

7-segment display on outdoor unit (interface P.C. board)

The interface control P.C. board features a 7-segment LED display designed to check operational status. Display items can be changed by changing the combination of the number settings of rotary switches provided on the P.C. board (SW01, SW02 and SW03).

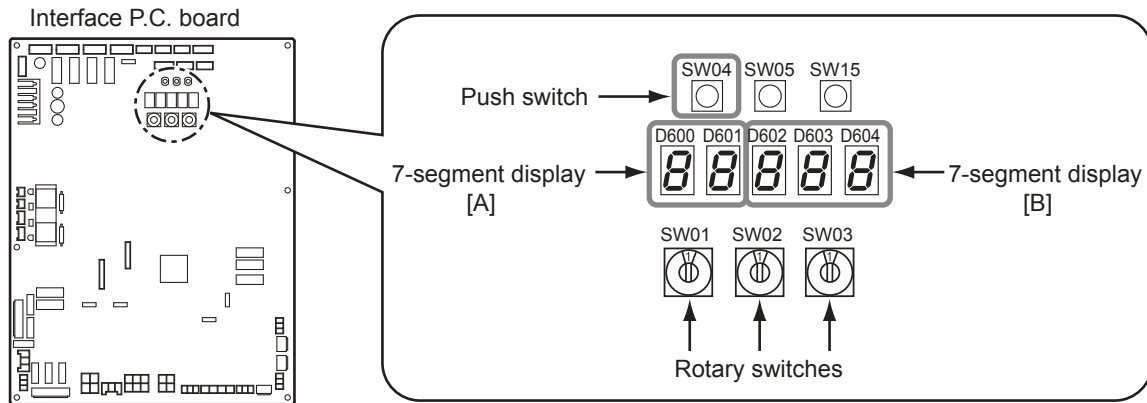

Checking Procedure to Be Followed in Event of Abnormal Shutdown

If the system is shut down due to a trouble in the outdoor unit, perform checks in the following steps:

1 Open the panel of the outdoor unit and inspection window of the electric parts box, and check the 7-segment display.

The check code is displayed in the right-hand section of the 7-segment display [B].

[U1] [000] ([000]: Check code)

* To check the check code, set the rotary switches SW01/SW02/SW03 to [1/1/1].

If there is a sub-code, the display alternates between the check code [000] (3 seconds) and the sub-code [000] (1 second).

2 Check the check code and follow the applicable diagnostic procedure.

3 If the 7-segment display shows [U1] [E28], there is a trouble in a follower unit.

Press the push-switch SW04 on the header unit and hold for several seconds.

As the fan of the outdoor unit in which the trouble has occurred comes on, open the panel of the unit, and check the check code shown on the 7-segment display.

4 Perform checks in accordance with the diagnostic procedure applicable to the check code.

(1) Display of System Information (Displayed on Header Outdoor Unit Only)

SW01	SW02	SW03	Display detail				
1	1	3	-		-		
	2		System capacity	A	[...8]~[54]:8 to 54 HP		
				B	[HP]		
	3		No. of outdoor units	A	[...1]~[...3]:1 to 3		
				B	[...P]		
	4		No. of indoor units connected / No. of units with cooling thermostat ON	A	[...0.]~[64.]:0 to 64 (No. of units connected)		
				B	[C...0]~[C64]:0 to 64 (No. of units with cooling thermostat ON)		
	5		No. of indoor units connected / No. of units with heating thermostat ON	A	[...0.]~[64.]:0 to 64 (No. of units connected)		
				B	[H...0]~[H64]:0 to 64 (No. of units with heating thermostat ON)		
	6		Amount of compressor command correction	A	Value displayed in hexadecimal format		
				B			
	7		Release control	A	Normal: [r. ...], During release control: [r.1]		
				B	-		
	8		Oil equalization control	Normal: [oiL-0]			
				During oil equalization control: [oiL-1]			
	9		Oil equalization request	A	Displayed through LED segment lighting pattern		
B		<p>If element F shown on sketch at left turned on: Header unit oil equalization request If element C shown on sketch at left turned on: Follower unit oil equalization request</p> <p>Outdoor unit No.</p>					
10	Refrigerant/oil recovery operation	A	Oil recovery in cooling: [C1], Normal: [C ...]				
		B	Refrigerant recovery in heating: [H1], Normal: [H ...]				
11	Automatic addressing	A	[Ad]				
		B	During automatic addressing: [... FF], Normal: [... ..]				
12	Power peak-cut	A	[dU]				
		B	Normal: [... ..], During 50-90% capacity operation: [_50-_90] While control is based on BUS line input: [E50-E90]				
13	Optional control (P.C. board input)	Displays optional control status			A	B	
		Operation mode selection: During priority heating (normal)			h.*	*.*.*	
		Priority cooling			c.*	*.*.*	
		Heating only			H.*	*.*.*	
		Cooling only			C.*	*.*.*	
		Priority given to No. of indoor units in operation			n.*	*.*.*	
		Priority given to specific indoor unit			U.*	*.*.*	
		External master ON/OFF: Normal			*....	*.*.*	
		Start input			*.1.	*.*.*	
		Stop input			*.0.	*.*.*	
		Night operation: Normal			*.*	...*.*	
		Start input			*.*	1.*.*	
		Snowfall operation: Normal			*.*	*....*	
Start input			*.*	*.1.*			
14	Optional control (BUS line input)	Same as above					
15	-	-					
16	-	-					

(2) Display of Outdoor Unit Information (Displayed on Each Outdoor Unit)

SW01	SW02	SW03	Display detail			
1	1		Check code data	A	Outdoor unit No.: [U1] to [U3]	
			B	Check code (only latest one displayed) If there is no check code, [— —] is displayed. If there is sub-code, check code [* * *] and sub-code [- * *] are displayed alternately, for 3 seconds and 1 second, respectively.		
				<SW04> push SW function: Fan operation at outdoor unit with trouble. 7-segment display section A: [E.1] <SW04 + SW05> push SW function: Fan operation at outdoor unit without trouble. 7-segment display section A: [E.0] <SW05> push SW function: Fan operation function check mode is cancelled.		
	2			A	—	
				B	—	
	3			A	Stop [.] Normal cooling: [. . . C], Normal heating: [. . . H], Normal defrosting: [. . . J]	
				B	—	
	4			A	8HP: [. . . 8], 10HP: [. . . 10], 12HP: [. . . 12], 14HP: [14], 16HP: [16], 18HP: [18], 20HP: [20]	
				B	[. . . HP]	
	5			Compressor operation command * Operation data of each compressor is displayed in turn in 2 second intervals.		
				Normal: Compressor speed (rps) is displayed in decimal format. 7-segment display (A/B): [C1.] ⇒ [. . . * * * , *] ⇒ [C2.] ⇒ [. . . * * * , *]		
				<SW04> push SW function: Switches to display of operating current (decimal value). 7-segment display (A/B): [i1. * * *] ⇒ [i2. * * *] Pressing of <SW05> restores normal display.		
	6			A	[FP]	
				B	Mode 0 to 63: [. . . 0] to [63]	
	7			A	[C.b.]	
				B	Displays compressor backup setting status Normal: [.] Compressor No. 1 backup: [1] Compressor No. 2 backup: [. . . 1 . . .]	
8		1	A	—		
			B	—		
9			Control valve output data			
			Displays control output status of solenoid valve			
				A	B	
			4-way valve: ON		H. 1
			4-way valve: OFF		H. 0
10			SV2: ON / SV5: OFF / SV52: ON / SV6: OFF		2. 1	0 1 0
			SV2: OFF / SV5: ON / SV52: OFF / SV6: OFF		2. 0	1 0 0
			SV2: OFF / SV5: OFF / SV52: OFF / SV6: ON		2. 0	0 0 1
11			SV3A: ON / SV3B: OFF / SV3C: OFF / SV3D: OFF		3. 1	0 0 0
			SV3A: OFF / SV3B: ON / SV3C: OFF / SV3D: OFF		3. 0	1 0 0
			SV3A: OFF / SV3B: OFF / SV3C: ON / SV3D: OFF		3. 0	0 1 0
			SV3A: OFF / SV3B: OFF / SV3C: OFF / SV3D: ON		3. 0	0 0 1
12			SV41: ON / SV42: OFF		4. . . .	1 0
			SV41: OFF / SV42: ON		4. . . .	0 1
			SV41: OFF / SV42: OFF		4. . . .	0 0
13			SV11A,B: ON / SV12: ON / SV14: ON		A. 1	1 1
			SV11A,B: OFF / SV12: OFF / SV14: OFF		A. 0	0 0
14			PMV1 opening		* *	* * .P
15			PMV4 opening		. . . *	* * .P
			Oil level judgment			
			Normal			
			A	[o L.]		
			B	Initial display: [.], Oil level judgment result: [L] Displayed letters #, * and \$ represent judgment results for compressor Nos. 1 and 2, respectively ("0" for normal and "1" or "2" for low level).		
16			<SW04> push SW function: Displays low level confirmed judgment result of each compressor. * Pressing of <SW05> restores normal display.			
			A	[L.d.]		
			B	Compressor No.1 low level being confirmed: [L] Compressor No.2 low level being confirmed: [. . . L . . .]		
			<SW15> push SW function: Switch to the data display of insufficient confirmation integration timer for 2 minutes			
			A	[t . . .]		
			B	Insufficient confirmation integration timer : [1 2 0] (Ex: for 120 minutes)		

(3) Display of Outdoor Cycle Data (Displayed at Each Outdoor Unit)

SW01	SW02	SW03	Display detail				
1	1	2	PD pressure data	PD pressure (MPaG) is displayed in decimal format. (MPaG: Approx. 10 times magnitude of kg/cm ² G)	A	B	
					P d.	*. * *	
			PS pressure data	PS pressure (MPaG) is displayed in decimal format.	P s.	*. * *	
	3		PL pressure conversion data	Converted PL pressure (MPaG) is displayed in decimal format.	P L.	*. * *	
	4		TD1 sensor data	Temperature sensor reading (°C) is displayed in decimal format. • Letter symbol and data are displayed alternately, for 1 second and display for 3 seconds, respectively. • Data with negative value is displayed as [- *] [* * *].	Letter symbol	t d	1
					Data	*	* * *
	5		TD2 sensor data		Letter symbol	t d	2
					Data	*	* * *
	7		TS1 sensor data		Letter symbol	t S	1
					Data	*	* * *
	8		TS2 sensor data		Letter symbol	t S	2
					Data	*	* * *
9	TE1 sensor data	Letter symbol	t E		1		
		Data	*		* * *		
10	TE2 sensor data	Letter symbol	t E		2		
		Data	*		* * *		
11	TL sensor data	Letter symbol	t L			
		Data	*	* * *			
12	TO sensor data	Letter symbol	t o			
		Data	*	* * *			

SW01	SW02	SW03	Display detail				
1	1	5	TK1 sensor data	Temperature sensor reading (°C) is displayed in decimal format. • Letter symbol and data are displayed alternately, for 1 second and display for 3 seconds, respectively. • Data with negative value is displayed as [- *] [* * *].	A	B	
					Letter symbol	F 1
	2		TK2 sensor data		Data	*	* * *
					Letter symbol	F 2
	4		TK4 sensor data		Data	*	* * *
					Letter symbol	F 4
	5		TK5 sensor data		Data	*	* * *
					Letter symbol	F 5
		Data	*	* * *			

(4) Display of Outdoor Cycle Data (Displayed at Header Unit)

* This method is used when displaying follower unit information on the 7-segment display of the header unit.

SW01	SW02	SW03	Display detail				
3	1	1~3	Check code data	A	[U.*], *: SW03 setting No. + 1 (Outdoor unit No. U2 to U3)		
				B	Check code is displayed (latest one only). If there is no check code: [- - -].		
	2		Type of compressor installed	A	[U.*], *: SW03 setting No. + 1 (Outdoor unit No. U2 to U3)		
				B			
	3		Outdoor unit HP capacity	A	[U.*], *: SW03 setting No. + 1 (Outdoor unit No. U2 to U3)		
				B	8HP: [... 8], 10HP: [... 10], 12HP: [... 12], 14HP: [14], 16HP: [16], 18HP: [18], 20HP: [20]		
	4		Compressor operation command	A	[U.*], *: SW03 setting No. + 1 (Outdoor unit No. U2 to U3)		
				B	Indicates which compressor is ON. * Any unconnected compressors is represented by "-".		
					When compressor No. 1 is ON	B	1 0
					When compressor No. 2 is ON		0 1
	5		Fan operation mode	A	[U.*], *: SW03 setting No. + 1 (Outdoor unit No. U2 to U3)		
				B	At rest: [F ... 0], In mode 63: [F 6 3]		
	6		Release signal	A	[U.*], *: SW03 setting No. + 1 (Outdoor unit No. U2 to U3)		
				B	Normal: [r], Upon receiving release signal: [r ... 1]		
	7		Oil level judgment	A	[U.*], *: SW03 setting No. + 1 (Outdoor unit No. U2 to U3)		
				B	Normal: [...], Low level: [... ... L]		
	8		Compressor 1 operating current	A	[U.*], *: SW03 setting No. + 1 (Outdoor unit No. U2 to U3)		
				B	[**.*], *.* is value of operating current in decimal format.		
9	Compressor 2 operating current	A	[U.*], *: SW03 setting No. + 1 (Outdoor unit No. U2 to U3)				
		B	[**.*], *.* is value of operating current in decimal format.				

Note: Follower unit is selected by setting SW03.

SW03	7-segment display section A
1	U2
2	U3

(5) Display of Indoor Unit Information (Displayed on Header Unit Only)

SW01	SW02	SW03	Display detail		
4	1~16	1~4	Indoor BUS communication signal receiving status	B Upon receiving signal: [... .. 1], Other times: [... ..]	
5			Indoor check code	B No check code: [- - -]	
6			Indoor HP capacity	B 0, 2, 0, 5, 0, 8, ... 1, 1, 2, 1, 7, ... 2, 2, 5, ...3, 3, 2, ...4, ...5, ...6, ...8, 1 0, 1 6, 2 0	
7			Indoor request command (S code, operation mode)	B [# *] # represents mode: COOL: [C. ... *], HEAT: [H. ... *] FAN: [F. ... *], OFF: [S. ... *] * represents S code: [# 0] to [# F]	
8			Indoor PMV opening data	B Displayed in decimal format	
9			Indoor TA / TRA opening data	B Displayed in decimal format	
10			11~14	Indoor TSA opening data	B Displayed in decimal format
			1~4	Indoor TF / TFA opening data	B Displayed in decimal format
11			11~14	Indoor TOA opening data	B Displayed in decimal format
			1~4	Indoor TCJ opening data	B Displayed in decimal format
				Indoor TC1 opening data	B Displayed in decimal format
13			Indoor TC2 opening data	B Displayed in decimal format	

Note: Indoor address No. is selected by setting SW02 and SW03 and displayed on 7-segment display, section A.

SW02	SW03	Indoor address	7-segment display section A
1~16	1	SW02 setting number	[01]~[16]
	11		
	2	SW02 setting number +16	[17]~[32]
	12		
	3	SW02 setting number +32	[33]~[48]
	13		
	4	SW02 setting number +48	[49]~[64]
	14		

(6) Display of Outdoor EEPROM Writing Check Code (Displayed on Header Unit Only)

* The latest code written in the EEPROM of each outdoor unit is displayed.

(This function is used to check the code after the resetting of the power supply.)

To display the code, push SW04 and hold for at least 5 seconds after setting SW01 to 03 as shown in the table below.

SW01	SW02	SW03	Indoor address	7-segment display section A	
1	1	16	Latest check code of header unit (U1)	E. 1.	***
	2		Latest check code of follower unit No. 1 (U2)	E. 2.	***
	3		Latest check code of follower unit No. 2 (U3)	E. 3.	***

• 7-Segment Display

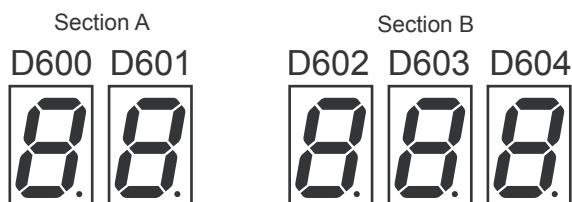

Set SW01/SW02/SW03 to [1/1/16] and push SW04 and hold for at least 5 seconds. The latest code of the header unit (U1) will be displayed.

If the setting of SW02 is changed, the latest code of a follow unit (U2-U3) will be displayed.

8-7. Oil Level Judgment Display

The current compressor oil level judgment results can be accessed by setting the switches provided on the interface P.C. board of an outdoor unit.

Perform the checks in accordance with the procedure described below.

1 Operation Procedure

- (1) Start the operation.
- (2) Set the switches provided on the interface P.C. board of the outdoor unit for which oil level judgment results are required as follows:
SW01/SW02/SW03 = 1/16/1
- (3) The oil level judgment result will be displayed on the 7-segment display.
7-segment display: [oL] [# . * . \$]
The letters #, * and \$ are digits that represent judgment results for compressor Nos. 1 and 2, respectively.
(See the table below for the interpretation of the judgment results.)
- (4) When checking is completed, revert the SW01/SW02/SW03 setting to [1/1/1].

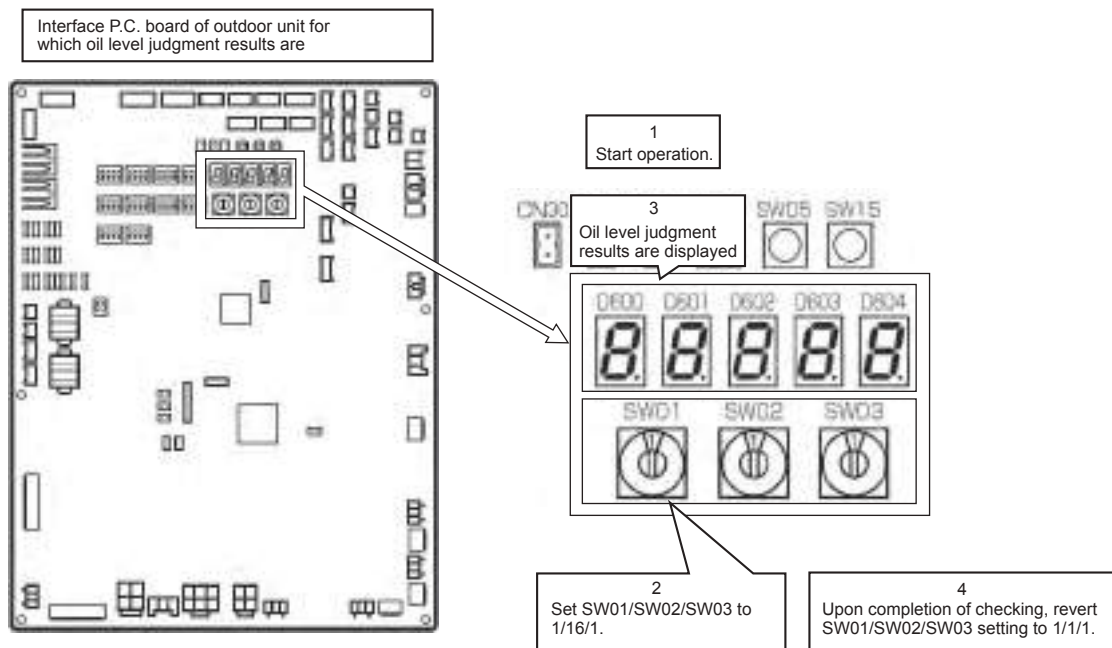

2 Oil Level Judgment Results

Displayed digit	Judgment result	Description
0	Normal	The amount of oil in the compressor is sufficient.
1 2	Low level	The amount of oil in the compressor is insufficient. (Both "1" and "2" stand for insufficiency.) If this result persists, the system will turn itself off in a protective shutdown.

Display example

7-segment display	[oL]	[0 0]	Oil level is normal for compressors 1 and 2.
	[oL]	[2 2]	Oil level is low for compressors 1 and 2.
	[oL]	[0 2]	Oil level is low for compressor 2 and normal for compressors 1.

└── Judgment result for compressor 2
 └── Judgment result for compressor 1

8-8. SHRM-e Outdoor Interface P.C. Board Function Setting Exchange Table

1. Switch/Function Setting Exchange

Part type		Exchange contents			Initial setting at shipment		
SW06	DIP SW 4 bit	bit 1	Compressor 1 backup	OFF: Normal, ON: Backup when compressor 1 was in trouble	OFF		
		bit 2	Compressor 2 backup	OFF: Normal, ON: Backup when compressor 2 was in trouble	OFF		
		All bit1 and 2 are ON: Setup of outdoor unit backup			OFF		
SW07	DIP SW 4 bit	bit 1	Demand control 1 (Standard specifications) Exchange of upper limit regulation	OFF: 0 to 100% ON : Middle to 100%	OFF		
		bit 2	Demand control 2 (Expansion function) Exchange of 2 steps to 4 steps of upper limit	OFF: 2 steps (Standard) ON : 4 steps	OFF		
SW09	DIP SW 4 bit	In case of center outdoor unit					
		bit 2	Indoor connection capacity over Judgment of trouble	OFF: Trouble judgment ON : None (when backup setting for outdoor unit)	OFF		
		bit 4	Judgment of trouble for No. of connected indoor units	OFF: No trouble judgment ON : Trouble judgment	OFF		
		In case of terminal outdoor unit					
SW10	DIP SW 4 bit	bit 4	Exchange of Outdoor unit No. / Start order No.	OFF: Outdoor unit No. [U. #] (#: 1 to 3) ON : Outdoor start order No. [y. #] (#: 1 to 3)	OFF		
		bit 2	Outdoor fan high static pressure operation	OFF: Normal ON : High static pressure operation	OFF		
		bit 3	For low noise operation	OFF: Normal ON : INV frequency upper limit restriction	OFF		
SW11	DIP SW 4 bit	bit 4	Operation switching when indoor water overflow trouble detected	OFF: Entire system stops ON : System operation continues (Room which trouble occurred only stops.)	OFF		
		bit 4	Operation switching when indoor water overflow trouble detected	OFF: Entire system stops ON : System operation continues (Room which trouble occurred only stops.)	OFF		
SW12	DIP SW 4 bit	bit 1	Selection of PMV open/close or manual operation	(According to the following setting contents)		OFF	
		bit 2				OFF	
		bit 1	bit 2	OFF	OFF	PMV1 opens/closes by operation of CN30/CN31 (*1)	
		bit 1	bit 2	OFF	ON	PMV4 opens/closes by operation of CN30/CN31 (*1)	
SW13	DIP SW 4 bit	bit 4	Line address setup	(Used by combining with SW14)	OFF		
SW14	DIP SW 4 bit	bit 1	Line address setup		OFF		
		bit 2			OFF		
		bit 3			OFF		
		bit 4			OFF		
SW16	DIP SW 4 bit	bit 1	Option function Output exchange of external output P.C. boa	(According to the following setting contents)		OFF	
		bit 2				OFF	
		bit 1	bit 2	OFF	OFF	Compressor operation output	
		bit 1	bit 2	ON	OFF	Display of system operation ratio	
SW30	DIP SW 2 bit	bit 1	Communication termination resistance between outdoor units	OFF: No termination resistance ON : With termination resistance	ON		
		bit 2	Communication termination resistance between indoor and outdoor units	OFF: No termination resistance ON : With termination resistance	ON		
CN30	Check connector	Manual full opening operation for PMV opening operation		When released: Normal, When short-circuited: Open fully (2 minutes)	Released		
CN31	Check connector	Manual full closing operation for PMV opening operation		When released: Normal, When short-circuited: Closed fully (2 minutes)	Released		

*1 PMV full open/full close operation by short-circuited CN30/CN31 is for PMV which was selected by setting of SW12.

2. Switching of Jumper Wire/Function

Setup Function switching setup

○ : With jumper, × : Without jumper (Cut)

jumper	Part type	Exchange contents		Initial setting at shipment
J01	Optional function Operation mode selection operation switching	○	Indoor unit at not selected side is kept with waiting status.	○
		×	The mode is changed a mode which selected the operation mode of the indoor unit at not selected side.	
J04	Upper limit setup of demand capacity command in corresponding indoor during saving operation in indoor	○	Approx. 75% (Normal)	○
		×	Approx. 60%	
J16	Demand control 1 (Standard specification) Corresponds to 2-core wire	○	Normal (3-core wire <Successive MAKE signal> or 4-core wire <Successive MAKE or Pulse signal>)	○
		×	2-core wire <Successive MAKE signal>	

*4 When you replace the board with a service board, be sure to cut the jumper wire matching with the outdoor unit model to be installed. (The jumper wires J09 to J12 which were mounted at shipment from the factory are provided to all the boards regardless of model type.)

Interface Board Switches and jumper wire positions to be used in the Function setup switching table

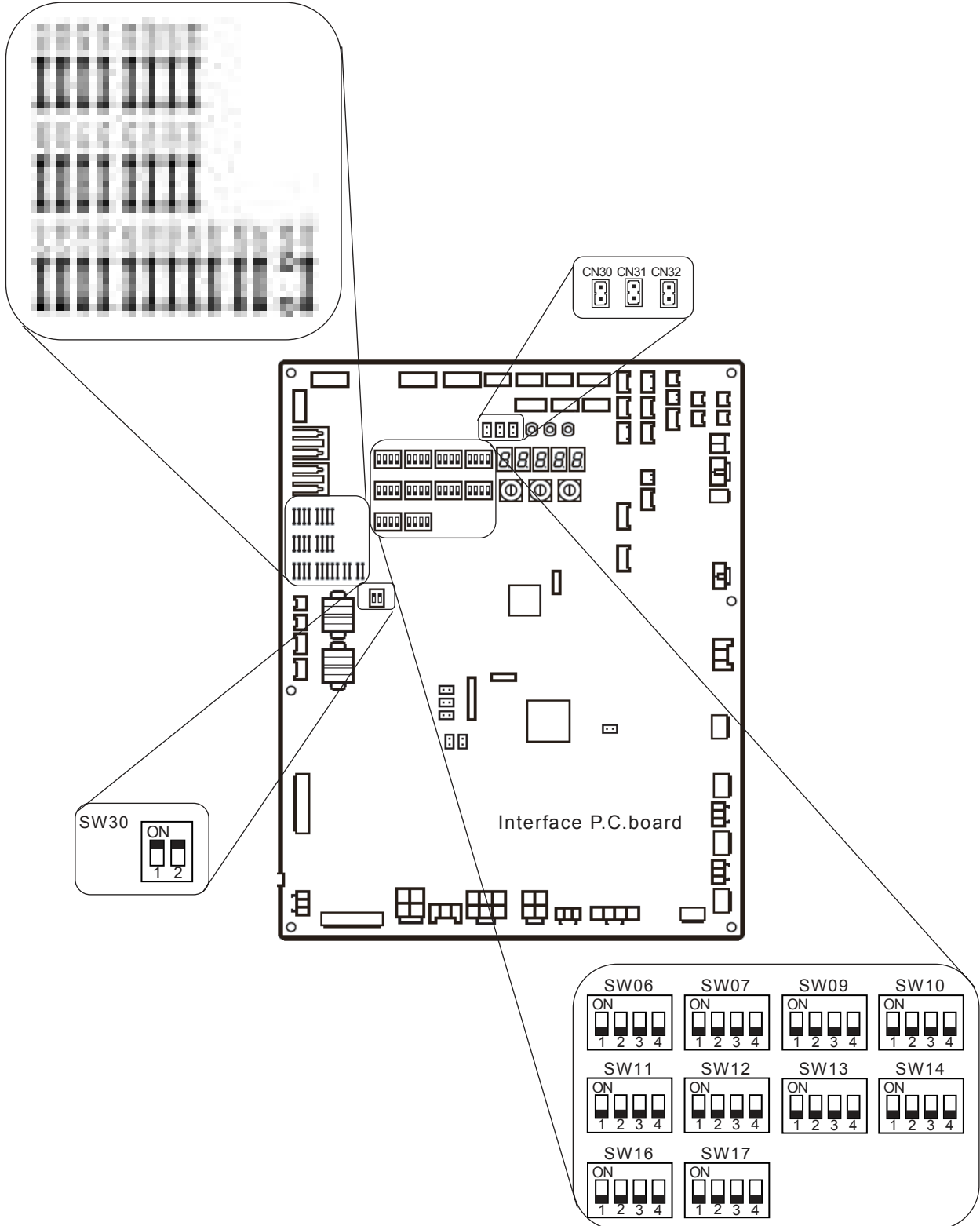

8-9. Leakage/Clogging of Refrigerating Cycle Circuit

List of Check Codes Generated upon Occurrence of Leakage/Clogging in Outdoor Cycle or Oil Circuit Part
(MMY-MAP0806*, 1006*)

Clogging

Part	Site of fault (see next page)	Check target unit	Detected fault and check code		Symptom
Outdoor PMV1, 4 SV14 valve SV14 valve circuit check valve	A	Corresponding unit	Activation of high-pressure protection Activation of low-pressure protection Discharge temp. trouble (TD1) Discharge temp. trouble (TD2)	P20 H06 P03 P17	Rise of abnormal pressure Fall of pressure Rise of discharge temp. (compressor 1) Rise of discharge temp. (compressor 2)
Check valve in discharge pipe convergent section SV11 valve SV11 valve circuit check valve	B	Corresponding unit	High-pressure protection operation High-pressure SW system trouble	P20 P04-XX	Abnormal rise of pressure
Check valve in discharge pipe	C	Corresponding unit	High-pressure SW system trouble	P04-XX	Abnormal rise of pressure
Check valve in oil-equalization circuit Capillary Strainer	D	Corresponding unit	Oil level detection circuit trouble Oil level low detection and protection	H16-XX H07-XX	Oil circuit trouble or oil shortage judgment
SV3A valve	E	Other connected unit	Oil level low detection and protection	H07-XX	Oil level low
SV3B valve	F	Corresponding unit	Oil level low detection and protection	H07-XX	Oil level low
SV3C valve	G	Other connected unit	Oil level low detection and protection	H07-XX	Oil level low
SV3D valve SV3D valve circuit capillary Strainer	H	Corresponding unit	Oil level low detection and protection	H07-XX	Oil level low
SV3E valve	I	Corresponding unit	Oil level detection circuit trouble Oil level low detection and protection	H16-05 H07-XX	Oil circuit trouble Oil level low Oil level low
Oil return distributor	J	Corresponding unit	Oil level low detection and protection	H07-XX	Oil level low
SV3C bypass capillary	K	Corresponding unit	Oil level detection circuit trouble	H16-04	Oil circuit trouble

Leakage

Part	Site of fault (see next page)	Check target unit	Detected fault and check code		Symptom
Outdoor PMV1	A	Corresponding unit	Outdoor liquid backflow trouble Oil level low detection and protection	P13 H07-XX	Refrigerant entrapment
		Other connected unit	Discharge temp. trouble (TD1) Discharge temp. trouble (TD2)	P03 P17	Rise of discharge temp. (compressor 1) Rise of discharge temp. (compressor 2)
Check valve in discharge pipe convergent section	B	Corresponding unit	Oil level low detection and protection Compressor breakdown Compressor trouble (lockup)	H07-XX H01-XX H02-XX	Refrigerant entrapment
Check valve in discharge pipe	C	Corresponding unit	Oil level low detection and protection Compressor breakdown Compressor trouble (lockup)	H07-XX H01-XX H02-XX	Refrigerant entrapment
Check valve in oil-equalization circuit	D	Corresponding unit	Oil level low detection and protection	H07-XX	Excessive amount of oil (Leaking side) Insufficient amount of oil (Normal side)
SV3A valve	E	Corresponding unit	Oil level low detection and protection	H07-XX	Oil level low
SV3C valve	G	Corresponding unit	Oil level low detection and protection	H07-XX	Oil level low

Note: "XX" represents sub-code

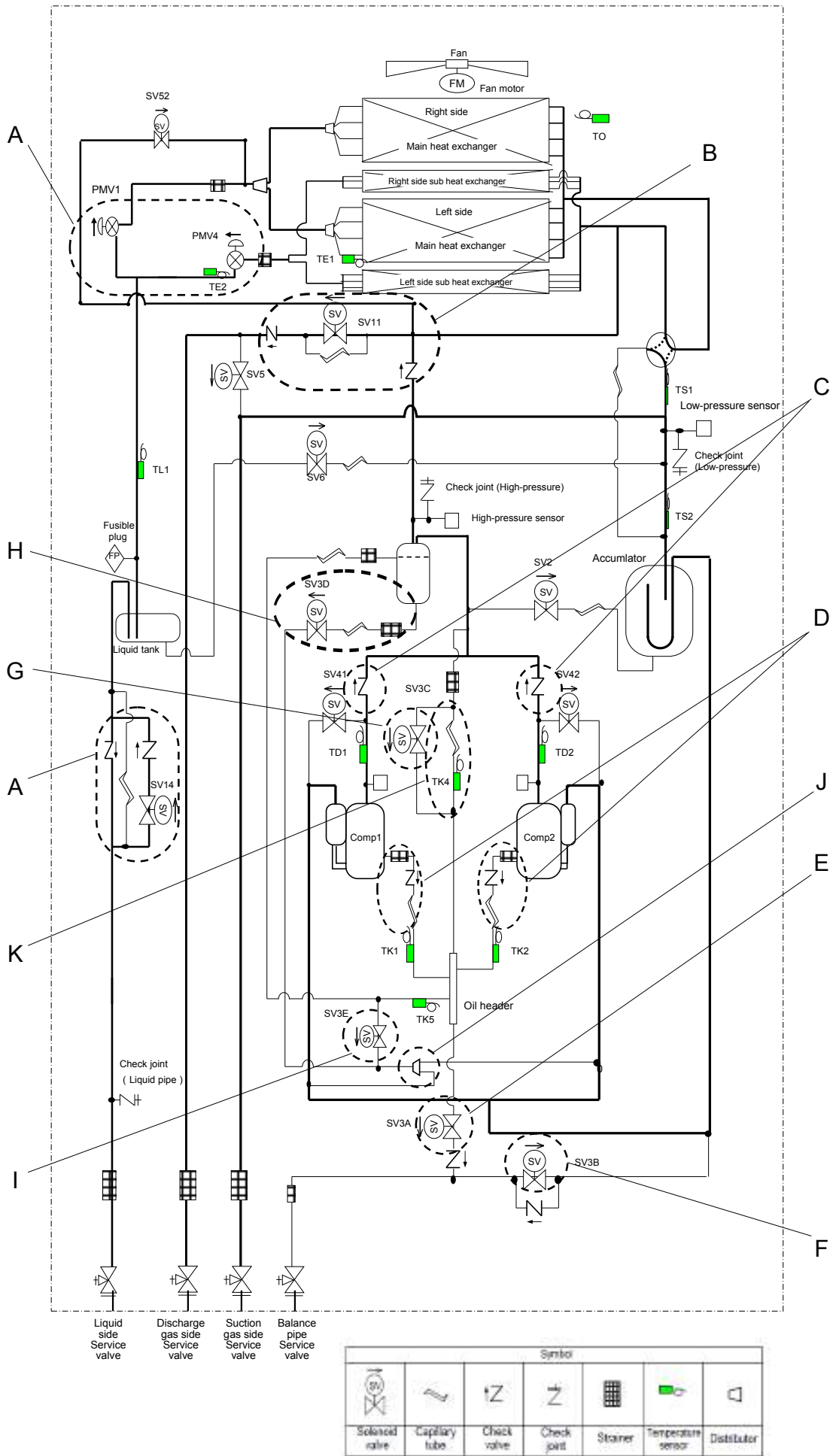

List of Check Codes Generated upon Occurrence of Leakage/Clogging in Outdoor Cycle or Oil Circuit Part (MMY-MAP1206*, 1406*)

Clogging

Part	Site of fault (see next page)	Check target unit	Detected fault and check code		Symptom
Outdoor PMV1, 4 SV14 valve SV14 valve circuit check valve	A	Corresponding unit	Activation of high-pressure protection Activation of low-pressure protection Discharge temp. trouble (TD1) Discharge temp. trouble (TD2)	P20 H06 P03 P17	Rise of abnormal pressure Fall of pressure Rise of discharge temp. (compressor 1) Rise of discharge temp. (compressor 2)
Check valve in discharge pipe convergent section SV11 valve SV11 valve circuit check valve	B	Corresponding unit	High-pressure protection operation High-pressure SW system trouble	P20 P04-XX	Abnormal rise of pressure
Check valve in discharge pipe	C	Corresponding unit	High-pressure SW system trouble	P04-XX	Abnormal rise of pressure
Check valve in oil-equalization circuit Capillary Strainer	D	Corresponding unit	Oil level detection circuit trouble Oil level low detection and protection	H16-XX H07-XX	Oil circuit trouble or oil shortage judgment
SV3A valve	E	Other connected unit	Oil level low detection and protection	H07-XX	Oil level low
SV3B valve	F	Corresponding unit	Oil level low detection and protection	H07-XX	Oil level low
SV3C valve	G	Other connected unit	Oil level low detection and protection	H07-XX	Oil level low
SV3D valve SV3D valve circuit capillary Strainer	H	Corresponding unit	Oil level low detection and protection	H07-XX	Oil level low
SV3E valve	I	Corresponding unit	Oil level detection circuit trouble Oil level low detection and protection	H16-05 H07-XX	Oil circuit trouble Oil level low Oil level low
Oil return distributor	J	Corresponding unit	Oil level low detection and protection	H07-XX	Oil level low
SV3C bypass capillary	K	Corresponding unit	Oil level detection circuit trouble	H16-04	Oil circuit trouble

Leakage

Part	Site of fault (see next page)	Check target unit	Detected fault and check code		Symptom
Outdoor PMV1	A	Corresponding unit	Outdoor liquid backflow trouble Oil level low detection and protection	P13 H07-XX	Refrigerant entrapment
		Other connected unit	Discharge temp. trouble (TD1) Discharge temp. trouble (TD2)	P03 P17	Rise of discharge temp. (compressor 1) Rise of discharge temp. (compressor 2)
Check valve in discharge pipe convergent section	B	Corresponding unit	Oil level low detection and protection Compressor breakdown Compressor trouble (lockup)	H07-XX H01-XX H02-XX	Refrigerant entrapment
Check valve in discharge pipe	C	Corresponding unit	Oil level low detection and protection Compressor breakdown Compressor trouble (lockup)	H07-XX H01-XX H02-XX	Refrigerant entrapment
Check valve in oil-equalization circuit	D	Corresponding unit	Oil level low detection and protection	H07-XX	Excessive amount of oil (Leaking side) Insufficient amount of oil (Normal side)
SV3A valve	E	Corresponding unit	Oil level low detection and protection	H07-XX	Oil level low
SV3C valve	G	Corresponding unit	Oil level low detection and protection	H07-XX	Oil level low

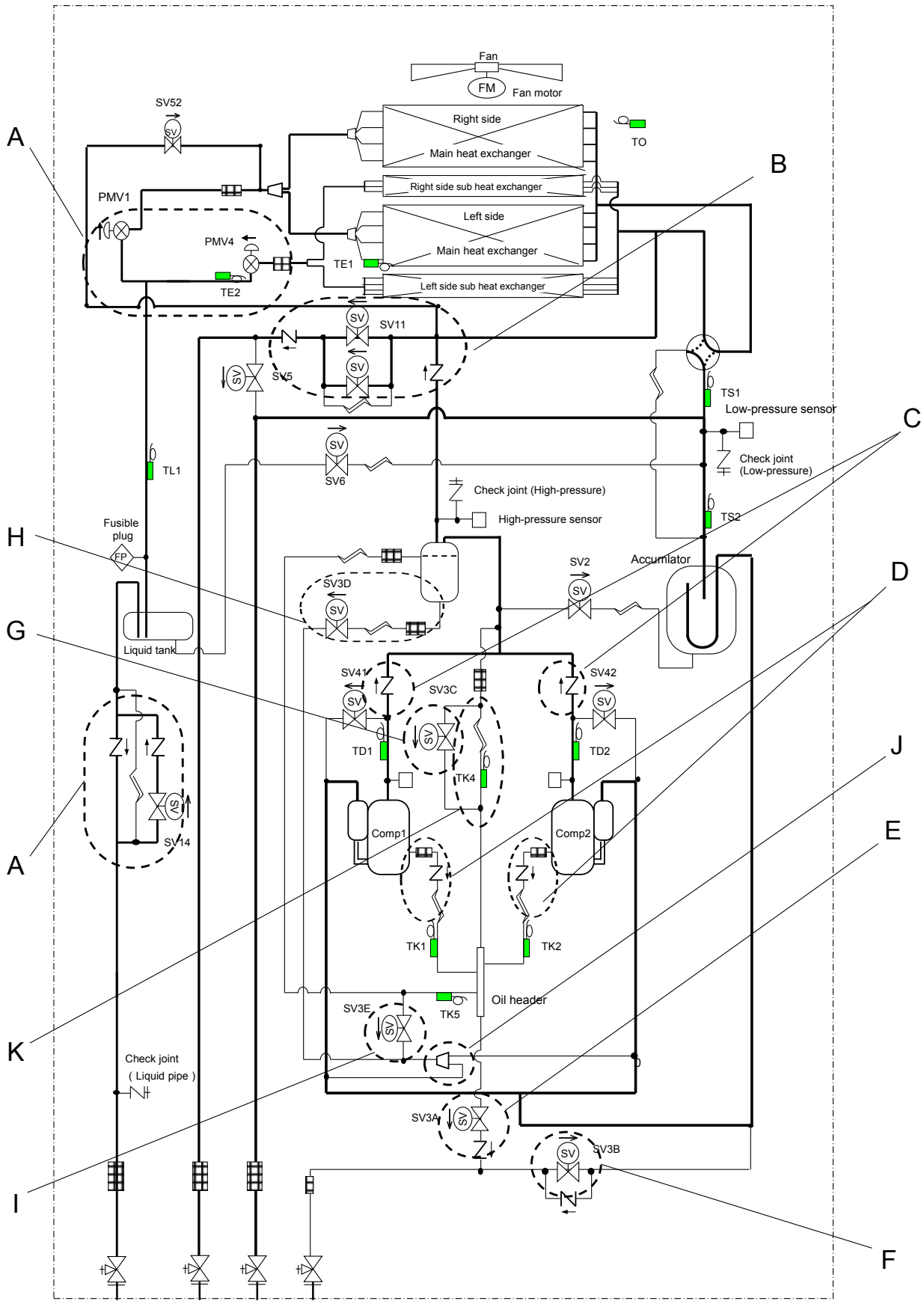

Liquid side Service valve
 Discharge gas side Service valve
 Suction gas side Service valve
 Balance pipe Service valve

Symbol						
Solaced valve	Capillary tube	Check valve	Check joint	Strainer	Temperature sensor	Distilator

List of Check Codes Generated upon Occurrence of Leakage/Clogging in Outdoor Cycle or Oil Circuit Part (MMY-MAP1606*, MAP1806* and MAP2006*)

Clogging

Part	Site of fault (see next page)	Check target unit	Detected fault and check code		Symptom
Outdoor PMV1,4 SV14 valve SV14 valve circuit check valve	A	Corresponding unit	Activation of high-pressure protection Activation of low-pressure protection Discharge temp. trouble (TD1) Discharge temp. trouble (TD2)	P20 H06 P03 P17	Rise of abnormal pressure Fall of pressure Rise of discharge temp. (compressor 1) Rise of discharge temp. (compressor 2)
Check valve in discharge pipe convergent section SV11 valve SV11 valve circuit check valve	B	Corresponding unit	High-pressure protection operation High-pressure SW system trouble	P20 P04-XX	Abnormal rise of pressure
Check valve in discharge pipe	C	Corresponding unit	High-pressure SW system trouble	P04-XX	Abnormal rise of pressure
Check valve in oil-equalization circuit Capillary Strainer	D	Corresponding unit	Oil level detection circuit trouble Oil level low detection and protection	H16-XX H07-XX	Oil circuit trouble or oil shortage judgment
SV3A valve	E	Other connected unit	Oil level low detection and protection	H07-XX	Oil level low
SV3B valve	F	Corresponding unit	Oil level low detection and protection	H07-XX	Oil level low
SV3C valve	G	Other connected unit	Oil level low detection and protection	H07-XX	Oil level low
SV3D valve SV3D valve circuit capillary Strainer	H	Corresponding unit	Oil level low detection and protection	H07-XX	Oil level low
SV3E valve	I	Corresponding unit	Oil level detection circuit trouble Oil level low detection and protection	H16-05 H07-XX	Oil circuit trouble Oil level low Oil level low
Oil return distributor	J	Corresponding unit	Oil level low detection and protection	H07-XX	Oil level low
SV3C bypass capillary	K	Corresponding unit	Oil level detection circuit trouble	H16-04	Oil circuit trouble

Leakage

Part	Site of fault (see next page)	Check target unit	Detected fault and check code		Symptom
Outdoor PMV1	A	Corresponding unit	Outdoor liquid backflow trouble Oil level low detection and protection	P13 H07-XX	Refrigerant entrapment
		Other connected unit	Discharge temp. trouble (TD1) Discharge temp. trouble (TD2)	P03 P17	Rise of discharge temp. (compressor 1) Rise of discharge temp. (compressor 2)
Check valve in discharge pipe convergent section	B	Corresponding unit	Oil level low detection and protection Compressor breakdown Compressor trouble (lockup)	H07-XX H01-XX H02-XX	Refrigerant entrapment
Check valve in discharge pipe	C	Corresponding unit	Oil level low detection and protection Compressor breakdown Compressor trouble (lockup)	H07-XX H01-XX H02-XX	Refrigerant entrapment
Check valve in oil-equalization circuit	D	Corresponding unit	Oil level low detection and protection	H07-XX	Excessive amount of oil (Leaking side) Insufficient amount of oil (Normal side)
SV3A valve	E	Corresponding unit	Oil level low detection and protection	H07-XX	Oil level low
SV3C valve	G	Corresponding unit	Oil level low detection and protection	H07-XX	Oil level low

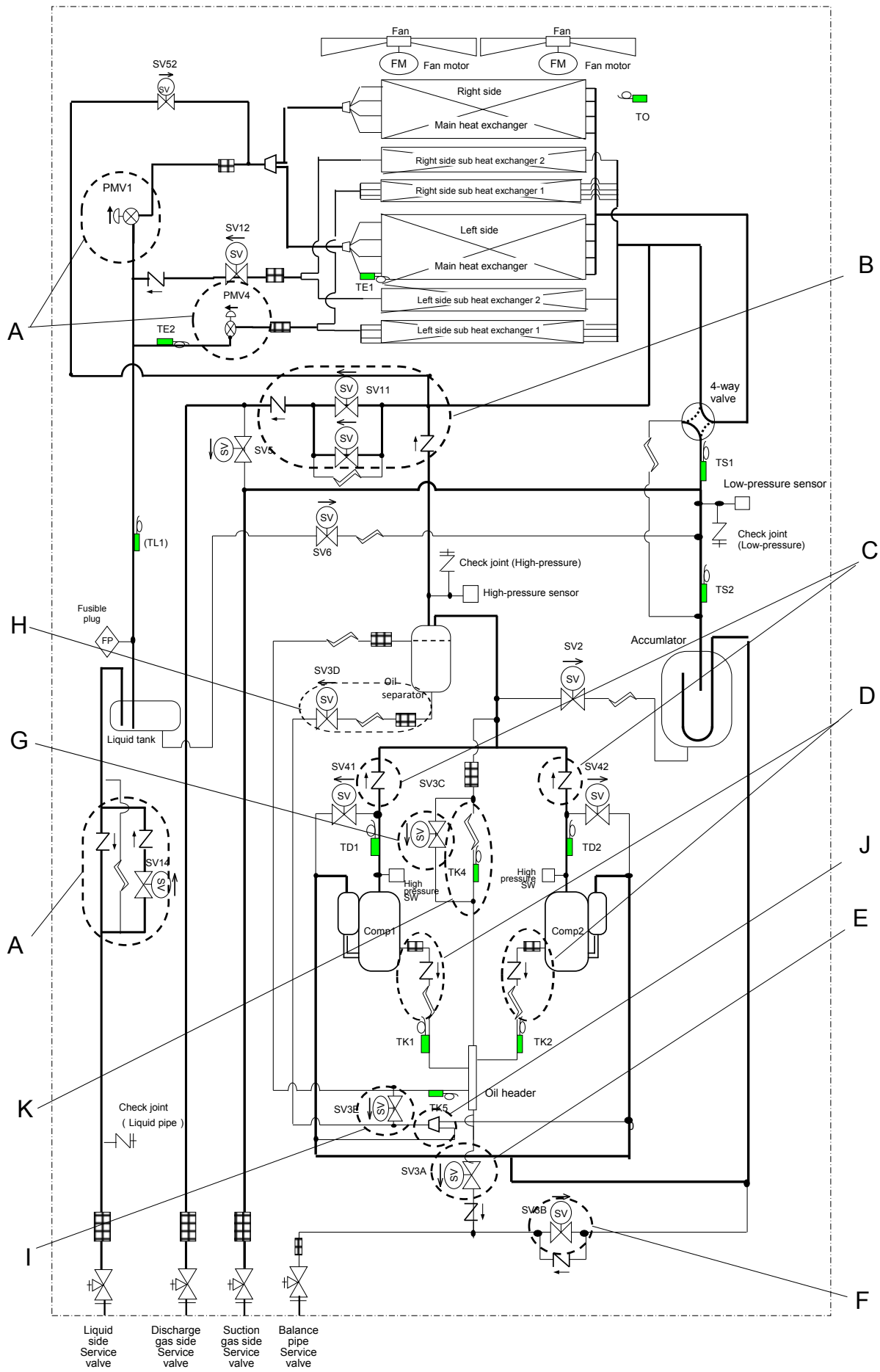

8-9-1. FS Unit

Leakage of SVD valve or SVS valve, etc; Positions to be checked and check code when a trouble such as miswiring occurred.

Part name	Trouble mode	Operation mode	Phenomenon which appears as result (Corresponding indoor unit or flow selector unit)				Judgment and position to be checked	Example of refrigerant flow
			Not cooled	Not heated	May become almost normal capacity	Abnormal refrigerant sound ● Circulating sound ○ SVD circuit – SVS circuit		
SVD valve	Clogging	Single heating Simultaneous cooling (Room heating) Simultaneous heating (Room heating)	<input type="radio"/>	<input type="radio"/>			<ul style="list-style-type: none"> TC1 is lower than normal indoor unit. Temperature of gas pipe at indoor side of the flow selector unit is lower than that of normal FS unit. 	
	Leakage	Single cooling (SV11 ON) Simultaneous cooling (Room cooling) Simultaneous heating (Room cooling)	<input type="radio"/>	<input type="radio"/>		<input type="radio"/>	<ul style="list-style-type: none"> Compared with normal indoor unit, TCJ is higher. Suction gas pipe at outdoor side of the flow selector unit is hot. Refrigerant circulating sound is heard in bypass from SVD valve to SVS valve. 	A
	Miswiring/ Misinstallation of coil SVD ↔ SVS	Single cooling (SV11 OFF)	<input type="radio"/>	<input type="radio"/>		<input type="radio"/>	<ul style="list-style-type: none"> TCJ is higher than normal indoor unit. Gas pipe at indoor side of the flow selector unit is not cold. Refrigerant circulating sound is heard from SVSS valve. 	
		Single cooling (SV11 ON) Simultaneous cooling (Room cooling) Simultaneous heating (Room cooling)	<input type="radio"/>	<input type="radio"/>		<input type="radio"/>	<ul style="list-style-type: none"> Temperature of TCJ and TC1 become high similar to heating. (All heating circuit) Discharge gas pipe at outdoor unit side of the flow selector unit is rather hot. Refrigerant circulating sound is not heard from SVS valve, but it is heard from SVD valve. 	B
SVS valve	Clogging	Single heating Simultaneous cooling (Room heating) Simultaneous heating (Room heating)	<input type="radio"/>	<input type="radio"/>			<ul style="list-style-type: none"> Gas pipe at indoor side of the flow selector unit is cold. (Cooling circuit, Liquid pack) Refrigerant circulating sound is not heard from SVD valve, but it is heard from SVS valve. 	C
	Leakage	Single cooling (Room cooling) Simultaneous heating (Room heating)	<input type="radio"/>	<input type="radio"/>		<input type="radio"/>	<ul style="list-style-type: none"> TCJ is higher than normal indoor unit. Gas pipe at indoor side of the flow selector unit is not cold. Refrigerant circulating sound is heard from SVSS valve. 	
		Single heating Simultaneous cooling (Room heating) Simultaneous heating (Room heating)	<input type="radio"/>	<input type="radio"/>		<input type="radio"/>	<ul style="list-style-type: none"> Compared with normal indoor unit, TCJ is low. Temperature of suction gas pipe at outdoor side of the flow selector unit is higher than that of normal flow selector unit. Refrigerant circulating sound is heard from SVS valve circuit. 	
	Clogging	Single heating Simultaneous cooling (Room heating) Simultaneous heating (Room heating)	<input type="radio"/>	<input type="radio"/>		<input type="radio"/>	<ul style="list-style-type: none"> In start time, when exchanging mode from cooling to heating after defrost operation, refrigerant shock sound may be heard. 	
SVDD valve	Leakage	Single cooling (SV11 ON) Simultaneous cooling (Room cooling) Simultaneous heating (Room cooling)	<input type="radio"/>	<input type="radio"/>		<input type="radio"/>	<ul style="list-style-type: none"> Refrigerant circulating sound may be heard from SVDD valve circuit. Suction gas pipe at outdoor unit side of the flow selector unit may be hot. 	
		Single heating Simultaneous cooling (Room heating) Simultaneous heating (Room heating)	<input type="radio"/>	<input type="radio"/>		<input type="radio"/>	<ul style="list-style-type: none"> Refrigerant circulating sound may be heard from SVDD valve circuit. 	
	Miswiring/ Misinstallation of coil SVD ↔ SVS	Single cooling (SV11 ON) Simultaneous cooling (Room cooling) Simultaneous heating (Room cooling)	<input type="radio"/>	<input type="radio"/>		<input type="radio"/>	<ul style="list-style-type: none"> Refrigerant circulating sound may be heard from SVDD valve circuit. Suction gas pipe at outdoor unit side of the flow selector unit may be hot. 	
		Single heating Simultaneous cooling (Room heating) Simultaneous heating (Room heating)	<input type="radio"/>	<input type="radio"/>		<input type="radio"/>	<ul style="list-style-type: none"> In start time, when exchanging mode from cooling to heating after defrost operation, refrigerant shock sound may be heard. 	

Part name	Trouble mode	Operation mode	Phenomenon which appears as result (Corresponding indoor unit or flow selector unit)					Judgment and position to be checked	Example of refrigerant flow
			Not cooled	Not heated	May become almost normal capacity	Abnormal refrigerant sound ● Circulating sound	Detection of check code		
SVSS valve	Clogging	Single cooling Simultaneous cooling (Indoor cooling) Simultaneous heating (Indoor cooling)			<input type="radio"/>	<input checked="" type="radio"/> Indoor unit, flow selector unit		<ul style="list-style-type: none"> Operation is changed from heating to cooling. Refrigerant impact sound is heard at defrost time. 	
		Single heating Simultaneous cooling (Indoor heating) Simultaneous heating (Indoor heating)			<input type="radio"/>	<input checked="" type="radio"/> Indoor unit, flow selector unit			
Discharge. Liquid bypass capillary, Check valve	Leakage	Single heating Simultaneous cooling (Indoor heating) Simultaneous heating (Indoor heating)			<input type="radio"/>	<input type="radio"/> SVSS circuit		<ul style="list-style-type: none"> Refrigerant sound may be heard from SVSS valve circuit. Temperature of suction gas pipe at outdoor side of the selector unit is higher than that of normal selector unit. 	
		Single cooling (SV11 ON) Simultaneous cooling (Indoor cooling) Simultaneous heating (Indoor cooling)	<input type="radio"/>				P15 [Gas leak detection]		
Piping Discharge pipe Liquid pipe Gas pipe	Check valve clogging	Single heating Simultaneous cooling (Indoor heating) Simultaneous heating (Indoor heating)		<input type="radio"/>				<ul style="list-style-type: none"> Gas short is observed and PD and PS may be lower than those in normal time. TD and TS may be higher than those in normal time. 	
		Single cooling (SV11 OFF)	<input type="radio"/>		<input type="radio"/> Check valve circuit				
Communication line Power supply line	Check valve leakage	Single cooling (SV11 OFF)			<input type="radio"/>		<ul style="list-style-type: none"> Refrigerant sound may be heard from check valve. Discharge gas pipe is cold or it may be frozen. Impossible judgment 		
		Single cooling (SV11 ON) Simultaneous cooling (Indoor cooling) Simultaneous heating (Indoor cooling)							
PMV	Incorrect piping Discharge pipe ↔ Suction gas pipe	Single heating Simultaneous cooling (Indoor heating) Simultaneous heating (Indoor heating)			<input type="radio"/>		<ul style="list-style-type: none"> TCJ and TC1 are heated same as heating. (Heating circuit) Suction gas pipe at outdoor side of selector unit is fairly heated. Temperature of suction gas pipe at outdoor side of the FS unit is higher than that of the normal FS unit. 	D	
		Single cooling Simultaneous heating (Indoor heating)							
In some cases, phenomena such as above occur.									
PMV	Disconnection line Contact trouble Miswiring	Single cooling Simultaneous cooling (Room heating)	<input type="radio"/>			<input type="radio"/> PMV circuit	<ul style="list-style-type: none"> Refrigerant sound may be heard from PMV. Temperature of TCS is lowered than the TCS of the other branch. 	E	
		Leakage							

<REFERENCE> An Example of Refrigerant Flow in FS Unit When Trouble Occurred

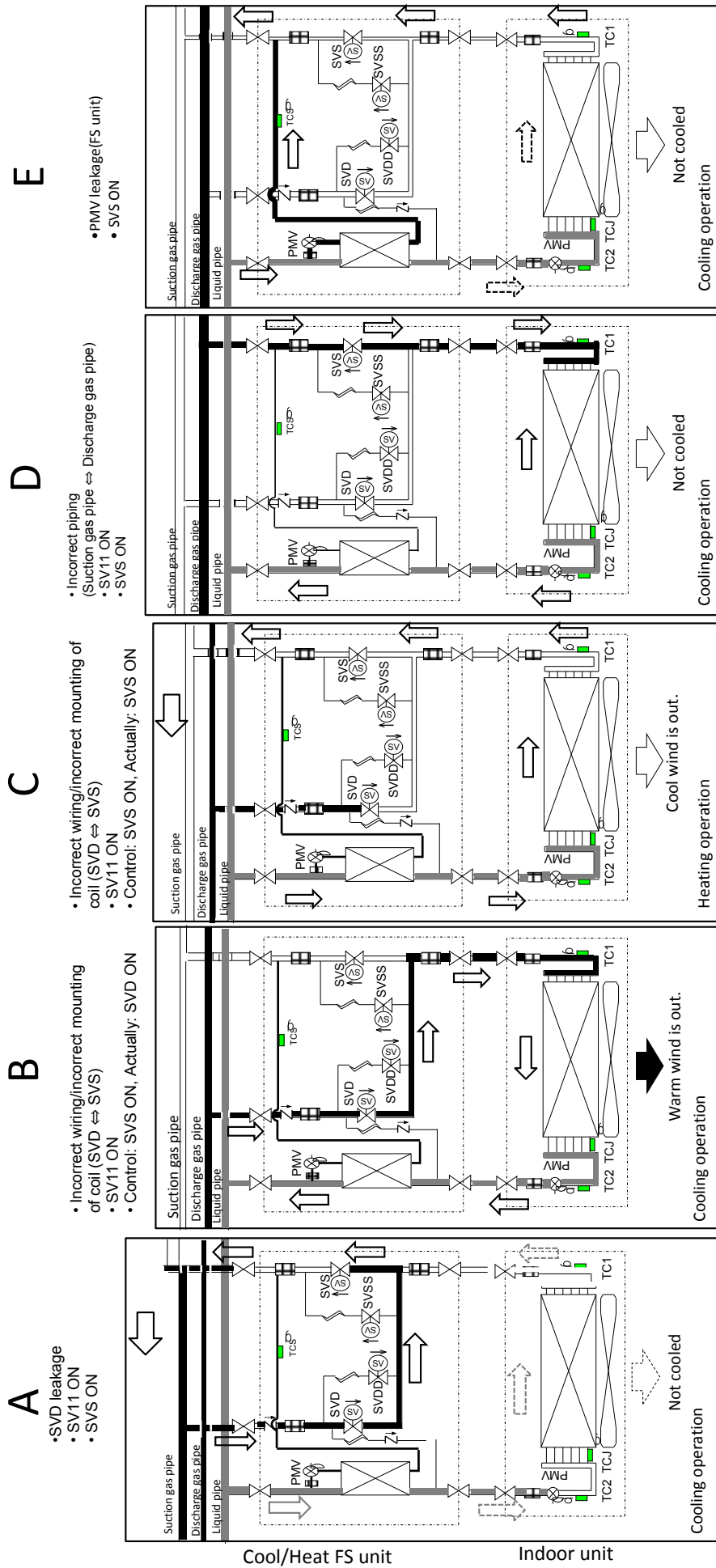

8-10. Sensor Characteristics

Outdoor Unit

▼ Temperature sensor characteristics

Outdoor TS1, TS2, TE1, TE2, TL1 and TO sensors

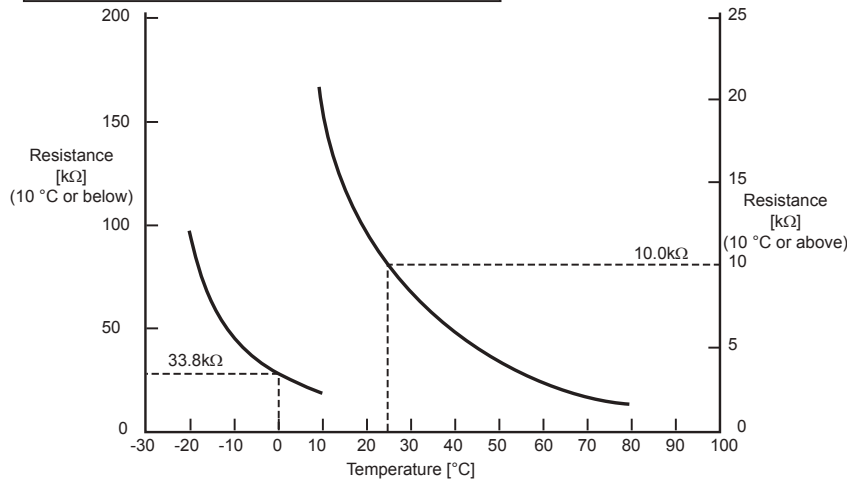

Temperature [°C]	Resistance [kΩ]
-20	102.9
-15	76.6
-10	57.8
-5	44.0
0	33.8
5	26.1
10	20.4
15	16.0
20	13.0
25	10.0
30	8.0
35	6.4
40	5.2
45	4.2
50	3.5
55	2.8
60	2.3
65	1.9
70	1.6
75	1.4
80	1.1

Outdoor TD1, TD2, TK1, TK2, TK4 and TK5 sensors

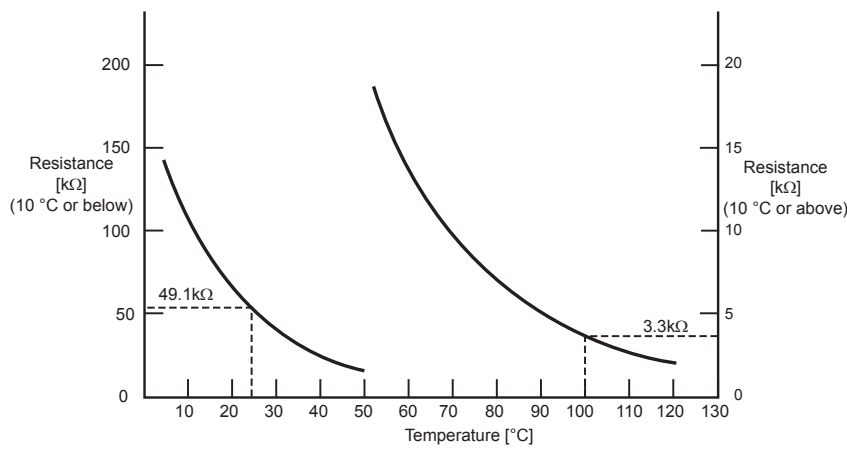

Temperature [°C]	Resistance [kΩ]
0	162.2
5	125.8
10	98.3
15	77.5
20	61.5
25	49.1
30	39.5
35	32.0
40	26.1
45	21.4
50	17.6
55	14.6
60	12.1
65	10.2
70	8.5
75	7.2
80	6.1
85	5.2
90	4.5
95	3.8
100	3.3
105	2.9
110	2.5
115	2.2
120	1.9

Outdoor Unit

▼ Pressure sensor characteristics

- Input/output wiring summary

Pin No.	High pressure side (PD)		Low pressure side (PS)	
	Input/output name	Lead wire color	Input/output name	Lead wire color
1	OUTPUT	White	—	—
2	—	—	OUTPUT	White
3	GND	Black	GND	Black
4	+5V	Red	+5V	Red

- Output voltage vs. pressure

High pressure side (PD)	Low pressure side (PS)
0.5~4.5V 0~3.92MPa	0.5~3.5V 0~0.98MPa

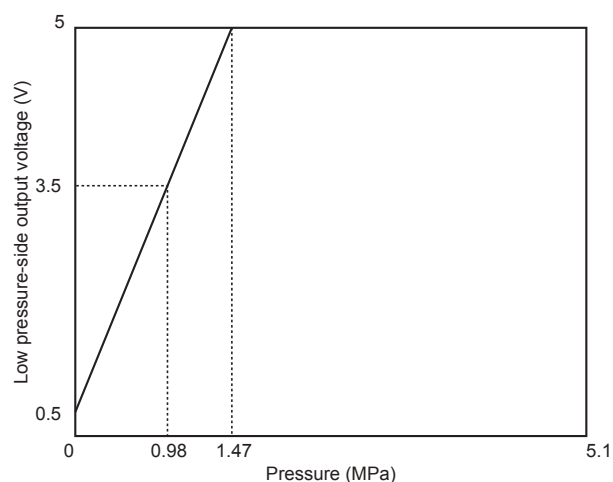
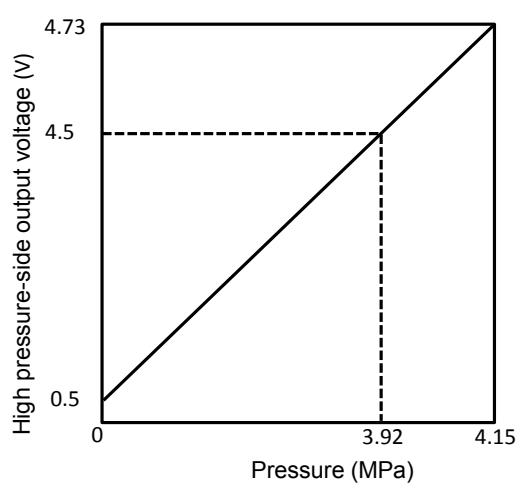

Indoor Unit

▼ Temperature sensor characteristics

Indoor TA(TSA), TRA,TF(TFA) sensor

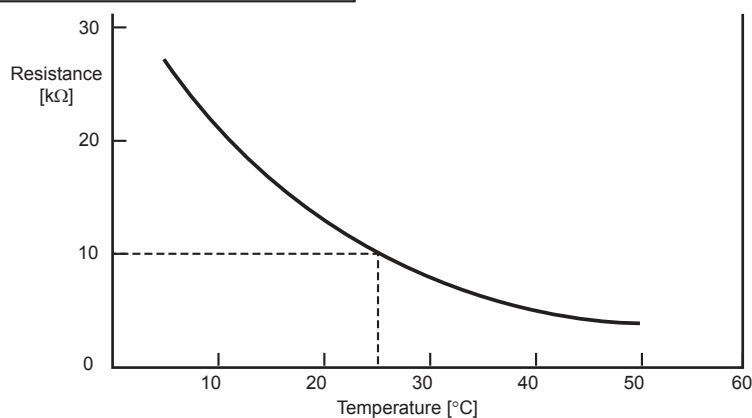

Temperature [°C]	Resistance [kΩ]
0	33.8
5	26.1
10	20.4
15	16.0
20	12.6
25	10.0
30	8.0
35	6.4
40	5.2
45	4.2
50	3.5
55	2.8
60	2.3

Indoor TC1 sensor

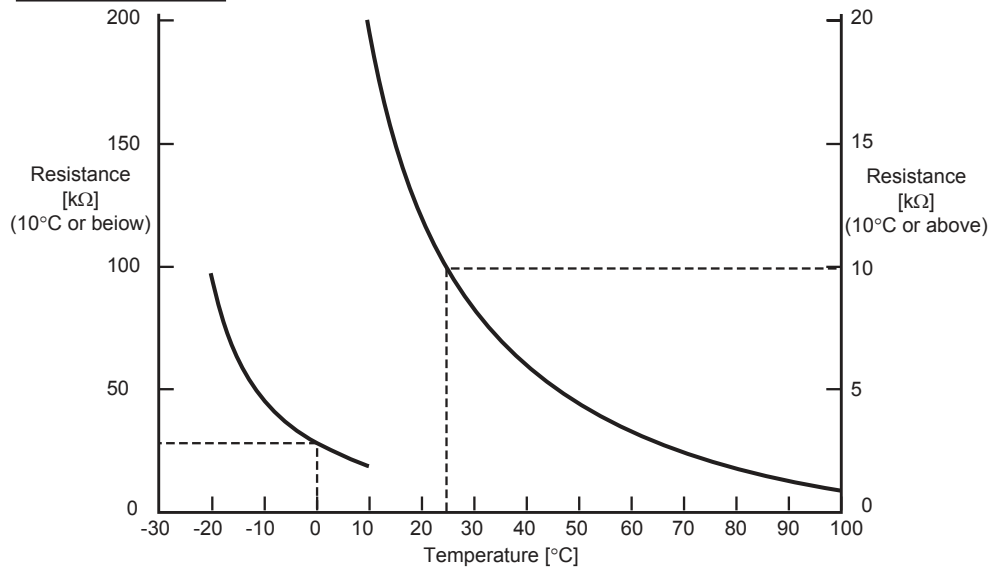

Temperature [°C]	Resistance [kΩ]
-20	98.3
-15	73.7
-10	55.8
-5	42.6
0	32.8
5	25.5
10	20.0
15	15.7
20	12.5
25	10.0
30	8.1
35	6.5
40	5.3
45	4.4
50	3.6
55	3.0
60	2.5
65	2.1
70	1.7
75	1.5
80	1.2
85	1.1
90	0.9
95	0.8
100	0.7

Indoor TC2 and TCJ, TOA sensor
FS unit TCS sensor

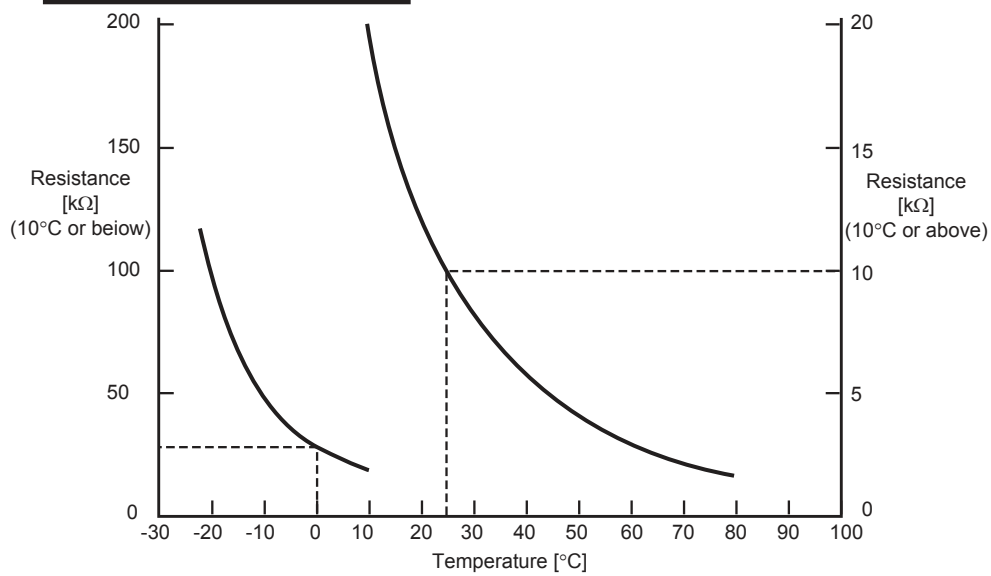

Temperature [°C]	Resistance [kΩ]
-20	102.9
-15	76.6
-10	57.7
-5	44.0
0	38.8
5	26.1
10	20.4
15	16.0
20	12.6
25	10.0
30	8.0
35	6.4
40	5.2
45	4.2
50	3.5
55	2.8
60	2.3
65	1.9
70	1.6
75	1.4
80	1.2

8-11. Pressure Sensor Output Check

Outdoor Unit

▼ PD sensor characteristics

0 to 4.41 MPa (0.5 to 4.73V output for 0 to 4.15 MPa)

Voltage readings across pins 2 and 3 of CN501 on indoor unit main P.C. board (with negative-side probe of multimeter placed on pin 3)

VOLT	PD (MPa)	PD (kg/cm ²)	VOLT	PD (MPa)	PD (kg/cm ²)	VOLT	PD (MPa)	PD (kg/cm ²)	VOLT	PD (MPa)	PD (kg/cm ²)	VOLT	PD (MPa)	PD (kg/cm ²)
0.00	0.00	0.0	1.00	0.49	5.0	1.99	1.46	14.9	2.99	2.44	24.9	3.98	3.42	34.8
0.02	0.00	0.0	1.02	0.51	5.2	2.01	1.48	15.1	3.01	2.46	25.1	4.00	3.44	35.0
0.04	0.00	0.0	1.04	0.53	5.4	2.03	1.50	15.3	3.03	2.48	25.3	4.02	3.45	35.2
0.06	0.00	0.0	1.06	0.54	5.5	2.05	1.52	15.5	3.05	2.50	25.5	4.04	3.48	35.4
0.08	0.00	0.0	1.07	0.56	5.7	2.07	1.54	15.7	3.07	2.52	25.7	4.06	3.49	35.6
0.10	0.00	0.0	1.09	0.58	5.9	2.09	1.56	15.9	3.09	2.54	25.9	4.08	3.51	35.8
0.12	0.00	0.0	1.11	0.60	6.1	2.11	1.58	16.1	3.11	2.56	26.1	4.10	3.53	36.0
0.14	0.00	0.0	1.13	0.62	6.3	2.13	1.60	16.3	3.13	2.57	26.3	4.12	3.55	36.2
0.16	0.00	0.0	1.15	0.64	6.5	2.15	1.62	16.5	3.15	2.59	26.4	4.14	3.57	36.4
0.18	0.00	0.0	1.17	0.66	6.7	2.17	1.64	16.7	3.16	2.61	26.6	4.16	3.59	36.6
0.20	0.00	0.0	1.19	0.68	6.9	2.19	1.66	16.9	3.18	2.63	26.8	4.18	3.61	36.8
0.22	0.00	0.0	1.21	0.70	7.1	2.21	1.67	17.1	3.20	2.65	27.0	4.20	3.63	37.0
0.23	0.00	0.0	1.23	0.72	7.3	2.23	1.69	17.3	3.22	2.67	27.2	4.22	3.65	37.2
0.25	0.00	0.0	1.25	0.74	7.5	2.25	1.71	17.5	3.24	2.69	27.4	4.24	3.67	37.4
0.27	0.00	0.0	1.27	0.76	7.7	2.27	1.73	17.7	3.26	2.71	27.6	4.26	3.69	37.6
0.29	0.00	0.0	1.29	0.77	7.9	2.29	1.75	17.9	3.28	2.73	27.8	4.28	3.70	37.8
0.31	0.00	0.0	1.31	0.79	8.1	2.31	1.77	18.0	3.30	2.75	28.0	4.30	3.72	38.0
0.33	0.00	0.0	1.33	0.81	8.3	2.32	1.79	18.2	3.32	2.77	28.2	4.32	3.74	38.2
0.35	0.00	0.0	1.35	0.83	8.5	2.34	1.81	18.4	3.34	2.79	28.4	4.34	3.76	38.4
0.37	0.00	0.0	1.37	0.85	8.7	2.36	1.83	18.6	3.36	2.80	28.6	4.36	3.78	38.6
0.39	0.00	0.0	1.39	0.87	8.9	2.38	1.85	18.8	3.38	2.82	28.8	4.38	3.80	38.8
0.41	0.00	0.0	1.41	0.89	9.1	2.40	1.87	19.0	3.40	2.84	29.0	4.40	3.82	38.9
0.43	0.00	0.0	1.43	0.91	9.3	2.42	1.89	19.2	3.42	2.86	29.2	4.41	3.84	39.1
0.45	0.00	0.0	1.45	0.93	9.5	2.44	1.90	19.4	3.44	2.88	29.4	4.43	3.86	39.3
0.47	0.00	0.0	1.47	0.95	9.6	2.46	1.92	19.6	3.46	2.90	29.6	4.45	3.88	39.5
0.49	0.00	0.0	1.48	0.97	9.8	2.48	1.94	19.8	3.48	2.92	29.8	4.47	3.90	39.7
0.51	0.01	0.1	1.50	0.99	10.0	2.50	1.96	20.0	3.50	2.94	30.0	4.49	3.92	39.9
0.53	0.03	0.3	1.52	1.00	10.2	2.52	1.98	20.2	3.52	2.96	30.2	4.51	3.93	40.1
0.55	0.05	0.5	1.54	1.02	10.4	2.54	2.00	20.4	3.54	2.98	30.4	4.53	3.95	40.3
0.57	0.07	0.7	1.56	1.04	10.6	2.56	2.02	20.6	3.56	3.00	30.5	4.55	3.97	40.5
0.59	0.08	0.9	1.58	1.06	10.8	2.58	2.04	20.8	3.57	3.02	30.7	4.57	3.99	40.7
0.61	0.10	1.1	1.60	1.08	11.0	2.60	2.06	21.0	3.59	3.03	30.9	4.59	4.01	40.9
0.63	0.12	1.3	1.62	1.10	11.2	2.62	2.08	21.2	3.61	3.05	31.1	4.61	4.03	41.1
0.65	0.14	1.4	1.64	1.12	11.4	2.64	2.10	21.4	3.63	3.07	31.3	4.63	4.05	41.3
0.66	0.16	1.6	1.66	1.14	11.6	2.66	2.12	21.6	3.65	3.09	31.5	4.65	4.07	41.5
0.68	0.18	1.8	1.68	1.16	11.8	2.68	2.13	21.8	3.67	3.11	31.7	4.67	4.09	41.7
0.70	0.20	2.0	1.70	1.18	12.0	2.70	2.15	22.0	3.69	3.13	31.9	4.69	4.11	41.9
0.72	0.22	2.2	1.72	1.20	12.2	2.72	2.17	22.2	3.71	3.15	32.1	4.71	4.13	42.1
0.74	0.24	2.4	1.74	1.21	12.4	2.73	2.19	22.3	3.73	3.17	32.3	4.73	4.15	42.3
0.76	0.26	2.6	1.76	1.23	12.6	2.75	2.21	22.5	3.75	3.19	32.5			
0.78	0.28	2.8	1.78	1.25	12.8	2.77	2.23	22.7	3.77	3.21	32.7			
0.80	0.30	3.0	1.80	1.27	13.0	2.79	2.25	22.9	3.79	3.23	32.9			
0.82	0.31	3.2	1.82	1.29	13.2	2.81	2.27	23.1	3.81	3.25	33.1			
0.84	0.33	3.4	1.84	1.31	13.4	2.83	2.29	23.3	3.83	3.26	33.3			
0.86	0.35	3.6	1.86	1.33	13.6	2.85	2.31	23.5	3.85	3.28	33.5			
0.88	0.37	3.8	1.88	1.35	13.8	2.87	2.33	23.7	3.89	3.30	33.7			
0.90	0.39	4.0	1.90	1.37	13.9	2.89	2.35	23.9	3.89	3.32	33.9			
0.92	0.41	4.2	1.91	1.39	14.1	2.91	2.36	24.1	3.91	3.34	34.1			
0.94	0.43	4.4	1.93	1.41	14.3	2.93	2.38	24.3	3.93	3.36	34.3			
0.96	0.45	4.6	1.95	1.43	14.5	2.95	2.40	24.5	3.95	3.38	34.5			
0.98	0.47	4.8	1.97	1.44	14.7	2.97	2.42	24.7	3.97	3.40	34.7			

Outdoor Unit

▼ PS sensor characteristics

0 to 1.47 MPa (0.5 to 5V output for 0 to 1.47 MPa)

Voltage readings across pins 2 and 3 of CN500 on indoor unit main P.C. board (with negative-side probe of multimeter placed on pin 3)

VOLT	PS (MPa)	PS (kg/cm ²)	VOLT	PS (MPa)	PS (kg/cm ²)	VOLT	PS (MPa)	PS (kg/cm ²)	VOLT	PS (MPa)	PS (kg/cm ²)	VOLT	PS (MPa)	PS (kg/cm ²)
0.00	0.00	0.0	1.00	0.16	1.7	1.99	0.49	5.0	2.99	0.81	8.3	3.98	1.14	11.6
0.02	0.00	0.0	1.02	0.17	1.7	2.01	0.49	5.0	3.01	0.82	8.4	4.00	1.15	11.7
0.04	0.00	0.0	1.04	0.18	1.8	2.03	0.50	5.1	3.03	0.83	8.4	4.02	1.15	11.7
0.06	0.00	0.0	1.06	0.18	1.8	2.05	0.51	5.2	3.05	0.83	8.5	4.04	1.16	11.8
0.08	0.00	0.0	1.07	0.19	1.9	2.07	0.51	5.2	3.07	0.84	8.6	4.06	1.17	11.9
0.10	0.00	0.0	1.09	0.19	2.0	2.09	0.52	5.3	3.09	0.85	8.6	4.08	1.17	11.9
0.12	0.00	0.0	1.11	0.20	2.0	2.11	0.53	5.4	3.11	0.85	8.7	4.10	1.18	12.0
0.14	0.00	0.0	1.13	0.21	2.1	2.13	0.53	5.4	3.13	0.86	8.8	4.12	1.18	12.1
0.16	0.00	0.0	1.15	0.21	2.2	2.15	0.54	5.5	3.15	0.86	8.8	4.14	1.19	12.1
0.18	0.00	0.0	1.17	0.22	2.2	2.17	0.55	5.6	3.16	0.87	8.9	4.16	1.20	12.2
0.20	0.00	0.0	1.19	0.23	2.3	2.19	0.55	5.6	3.18	0.88	8.9	4.18	1.20	12.3
0.22	0.00	0.0	1.21	0.23	2.4	2.21	0.56	5.7	3.20	0.88	9.0	4.20	1.21	12.3
0.23	0.00	0.0	1.23	0.24	2.4	2.23	0.56	5.8	3.22	0.89	9.1	4.22	1.22	12.4
0.25	0.00	0.0	1.25	0.25	2.5	2.25	0.57	5.8	3.24	0.90	9.1	4.24	1.22	12.5
0.27	0.00	0.0	1.27	0.25	2.6	2.27	0.58	5.9	3.26	0.90	9.2	4.26	1.23	12.5
0.29	0.00	0.0	1.29	0.26	2.6	2.29	0.58	6.0	3.28	0.91	9.3	4.28	1.24	12.6
0.31	0.00	0.0	1.31	0.26	2.7	2.31	0.59	6.0	3.30	0.92	9.3	4.30	1.24	12.7
0.33	0.00	0.0	1.33	0.27	2.8	2.32	0.60	6.1	3.32	0.92	9.4	4.32	1.25	12.7
0.35	0.00	0.0	1.35	0.28	2.8	2.34	0.60	6.1	3.34	0.93	9.5	4.34	1.25	12.8
0.37	0.00	0.0	1.37	0.28	2.9	2.36	0.61	6.2	3.36	0.94	9.5	4.36	1.26	12.9
0.39	0.00	0.0	1.39	0.29	3.0	2.38	0.62	6.3	3.38	0.94	9.6	4.38	1.27	12.9
0.41	0.00	0.0	1.41	0.30	3.0	2.40	0.62	6.3	3.40	0.95	9.7	4.40	1.27	13.0
0.43	0.00	0.0	1.43	0.30	3.1	2.42	0.63	6.4	3.42	0.95	9.7	4.41	1.28	13.0
0.45	0.00	0.0	1.45	0.31	3.2	2.44	0.64	6.5	3.44	0.96	9.8	4.43	1.29	13.1
0.47	0.00	0.0	1.47	0.32	3.2	2.46	0.64	6.5	3.46	0.97	9.9	4.45	1.29	13.2
0.49	0.00	0.0	1.48	0.32	3.3	2.48	0.65	6.6	3.48	0.97	9.9	4.47	1.30	13.2
0.51	0.00	0.0	1.50	0.33	3.3	2.50	0.65	6.7	3.50	0.98	10.0	4.49	1.31	13.3
0.53	0.01	0.1	1.52	0.34	3.4	2.52	0.66	6.7	3.52	0.99	10.1	4.51	1.31	13.4
0.55	0.02	0.2	1.54	0.34	3.5	2.54	0.67	6.8	3.54	0.99	10.1	4.53	1.32	13.4
0.57	0.02	0.2	1.56	0.35	3.5	2.56	0.67	6.9	3.56	1.00	10.2	4.55	1.32	13.5
0.59	0.03	0.3	1.58	0.35	3.6	2.58	0.68	6.9	3.57	1.01	10.2	4.57	1.33	13.6
0.61	0.03	0.4	1.60	0.36	3.7	2.60	0.69	7.0	3.59	1.01	10.3	4.59	1.34	13.6
0.63	0.04	0.4	1.62	0.37	3.7	2.62	0.69	7.1	3.61	1.02	10.4	4.61	1.34	13.7
0.65	0.05	0.5	1.64	0.37	3.8	2.64	0.70	7.1	3.63	1.02	10.4	4.63	1.35	13.8
0.66	0.05	0.5	1.66	0.38	3.9	2.66	0.71	7.2	3.65	1.03	10.5	4.65	1.36	13.8
0.68	0.06	0.6	1.68	0.39	3.9	2.68	0.71	7.3	3.67	1.04	10.6	4.67	1.36	13.9
0.70	0.07	0.7	1.70	0.39	4.0	2.70	0.72	7.3	3.69	1.04	10.6	4.69	1.37	14.0
0.72	0.07	0.7	1.72	0.40	4.1	2.72	0.72	7.4	3.71	1.05	10.7	4.71	1.38	14.0
0.74	0.08	0.8	1.74	0.41	4.1	2.73	0.73	7.4	3.73	1.06	10.8	4.73	1.38	14.1
0.76	0.09	0.9	1.76	0.41	4.2	2.75	0.74	7.5	3.75	1.06	10.8	4.75	1.39	14.2
0.78	0.09	0.9	1.78	0.42	4.3	2.77	0.74	7.6	3.77	1.07	10.9	4.77	1.39	14.2
0.80	0.10	1.0	1.80	0.42	4.3	2.79	0.75	7.6	3.79	1.08	11.0	4.79	1.40	14.3
0.82	0.11	1.1	1.82	0.43	4.4	2.81	0.76	7.7	3.81	1.08	11.0	4.81	1.41	14.3
0.84	0.11	1.1	1.84	0.44	4.5	2.83	0.76	7.8	3.83	1.09	11.1	4.82	1.41	14.4
0.86	0.12	1.2	1.86	0.44	4.5	2.85	0.77	7.8	3.85	1.09	11.2	4.84	1.42	14.5
0.88	1.12	1.3	1.88	0.45	4.6	2.87	0.78	7.9	3.89	1.10	11.2	4.86	1.43	14.5
0.90	0.13	1.3	1.90	0.46	4.6	2.89	0.78	8.0	3.89	1.11	11.3	4.88	1.43	14.6
0.92	0.14	1.4	1.91	0.46	4.7	2.91	0.79	8.0	3.91	1.11	11.4	4.90	1.44	14.7
0.94	0.14	1.5	1.93	0.47	4.8	2.93	0.79	8.1	3.93	1.12	11.4	4.92	1.45	14.7
0.96	0.15	1.5	1.95	0.48	4.8	2.95	0.80	8.2	3.95	1.13	11.5	4.94	1.45	14.8
0.98	0.16	1.6	1.97	0.48	4.9	2.97	0.81	8.2	3.97	1.13	11.5	4.96	1.46	14.9
												4.98	1.47	14.9

9 BACKUP OPERATION (EMERGENCY OPERATION)

This product offers backup modes of operation to tide over certain emergency situations. If a fault occurs in one of the compressors, it is possible to operate the system on an emergency basis by operating only the remaining compressor, (compressor backup operation).

If one of the outdoor units fails in a combined outdoor unit system, the system can be operated on an emergency basis by keeping only the remaining outdoor unit(s), (outdoor unit backup operation).

Perform backup operation setting in accordance with the procedure described below.

9-1. Note for Backup Operation

The method of backup operation differs according to the contents of fault as shown in the table below.

Contents of fault	Method of backup operation	Setting procedure
One of the compressors in the same unit fails (see Note 1)	Compressor backup (see Note 2)	Go to 9-2.
All the compressors in the same unit fail	Outdoor unit backup or cooling-season outdoor unit backup (see Notes 1, 3, 4 and 5)	Go to 9-3. or 9-4.
A fault occurs in a compressor motor coil (e.g. a layer short-circuit)		
A fault occurs in a refrigerating cycle part, fan or related part, or electrical part		
A fault occurs in a temperature sensor or pressure sensor		

Note 1: If the compressor has failed due to a fault in its motor coil (e.g. a layer short-circuit), do not perform compressor backup operation because of severe oil degradation. It could damage other outdoor units.

Note 2: Keep the number of backed-up outdoor units under compressor backup operation to one in the system (single refrigerant line).

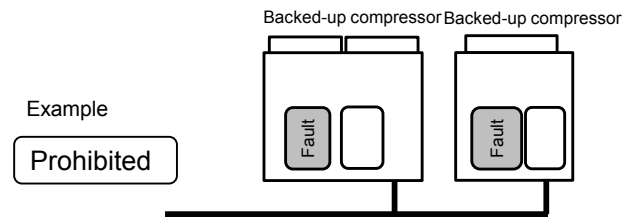

Note 3: Keep the number of backed-up outdoor units under outdoor unit backup operation to one in the system (single refrigerant line).

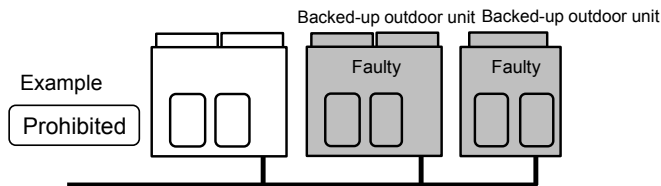

Note 4: It is prohibited to combine compressor backup operation and outdoor unit backup operation.

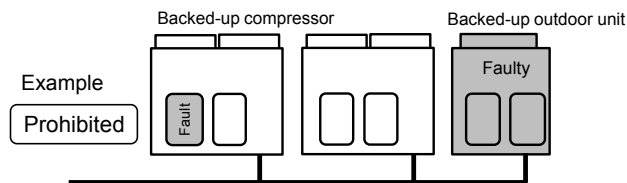

Note 5: When the chassis of different size are combined, do not perform back up operation with the large size chassis.

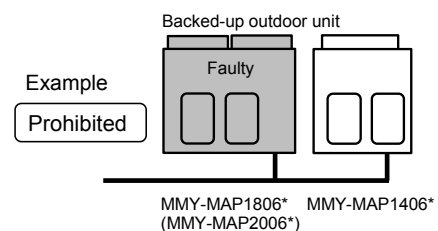
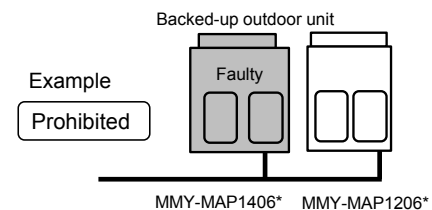

9-2. Compressor Backup Operation Setting

<Outline>

If a fault occurs to one of the compressors installed in outdoor unit, follow the procedure described below to back up the faulty compressor by using the remaining, normal compressor.

<Work Procedure>

- (1) Turn off the power supply to all the outdoor units connected to the system.
- (2) Set the DIP switches of SW06, provided on the interface P.C. board of the outdoor unit with the faulty compressor, as shown in the table below.

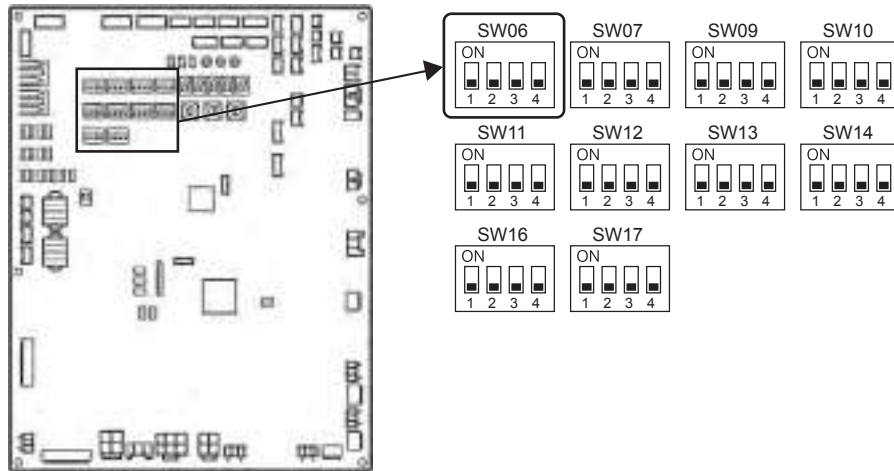

Two-compressor model	SW06			
	Bit 1	Bit 2	Bit 3	Bit 4
Factory default setting	OFF	OFF	OFF	OFF
When compressor No.1 (front left) is faulty	ON	OFF	OFF	OFF
When compressor No.2 (front right) is faulty	OFF	ON	OFF	OFF

(3) Change the connection of wiring between Comp-IPDU and Fan-IPDU, as shown in the below.

Outdoor Unit (8, 10, 12, 14HP)

Model: MMY-MAP0806FT*, MAP1006FT*, MAP1206FT*, MAP1406FT*

1. When compressor No.1 (front left) is faulty : No change the connection of wiring

2. When compressor No.2 (front right) is faulty :

Change the connection of wiring between Comp-IPDU and Fan-IPDU as shown in the below.

Ex. MMY-MAP0806FT*, MAP1006FT*

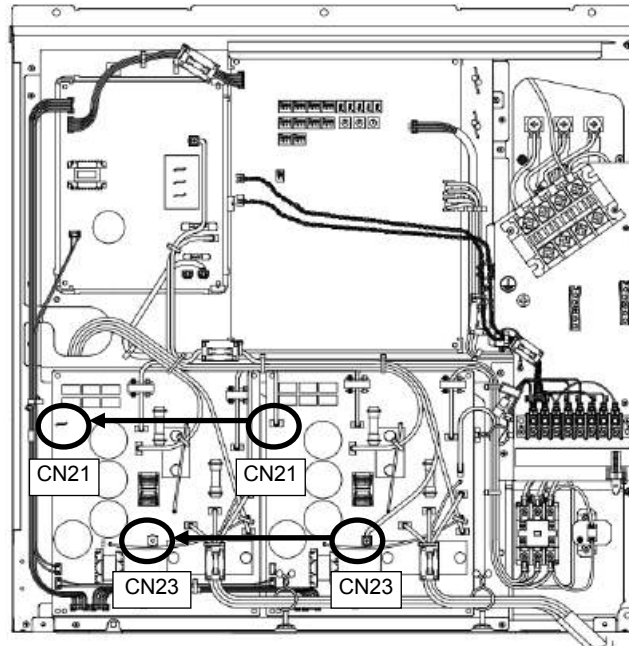

Change the connection of wiring which is connected to the CN21, 23 of Comp-IPDU2

- Change to CN21 of Comp-IPDU1 from CN21 of Comp-IPDU2
- Change to CN23 of Comp-IPDU2 from CN23 of Comp-IPDU2

Ex. MMY- MAP1206FT*, MAP1406FT*

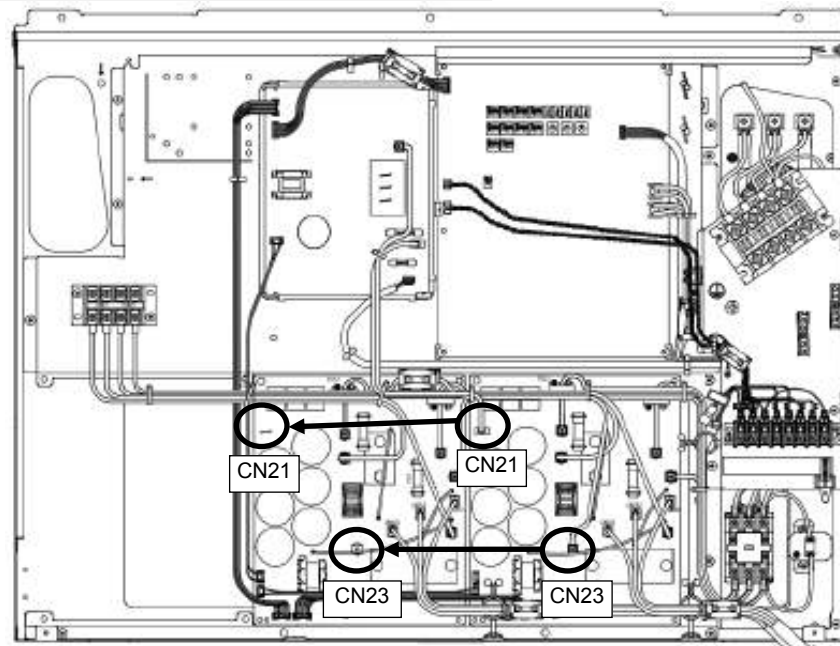

Change the connection of wiring which is connected to the CN21, 23 of Comp-IPDU2

- Change to CN21 of Comp-IPDU1 from CN21 of Comp-IPDU2
- Change to CN23 of Comp-IPDU2 from CN23 of Comp-IPDU2

Outdoor Unit (16, 18, 20HP)

Model: MMY-MAP1606FT*, MAP1806FT*, MAP2006FT*

1. When compressor No.1 (front left) is faulty :

Change the connection of wiring between Comp-IPDU and Fan-IPDU as shown in the below.

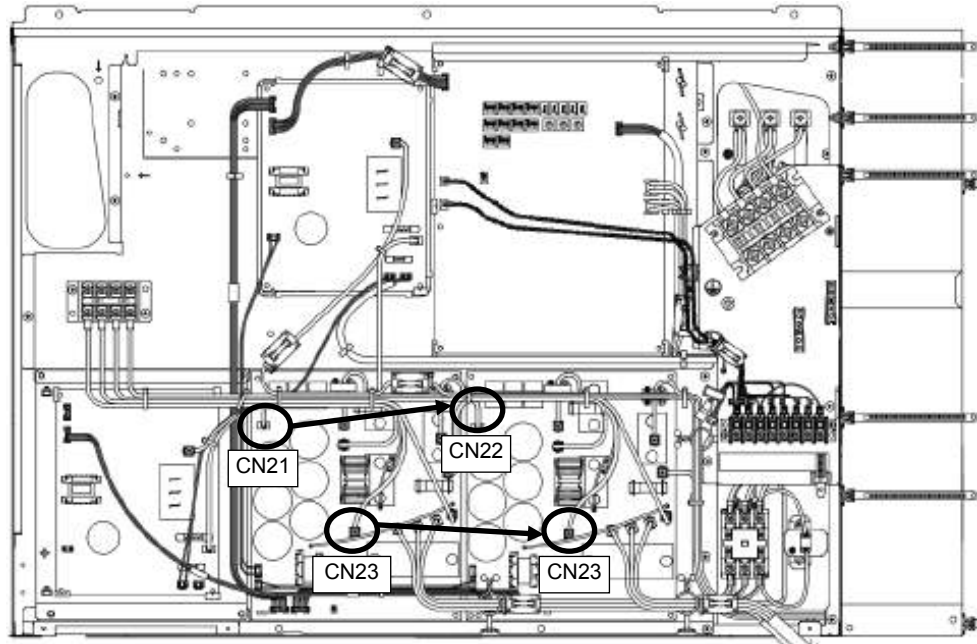

Change the connection of wiring which is connected to the CN21, 23 of Comp-IPDU1

- Change to CN22 of Comp-IPDU2 from CN21 of Comp-IPDU1
- Change to CN23 of Comp-IPDU2 from CN23 of Comp-IPDU1
(Tighten two wirings together with screw terminal)

2. When compressor No.2 (front right) is faulty :

Change the connection of wiring between Comp-IPDU and Fan-IPDU as shown in the below.

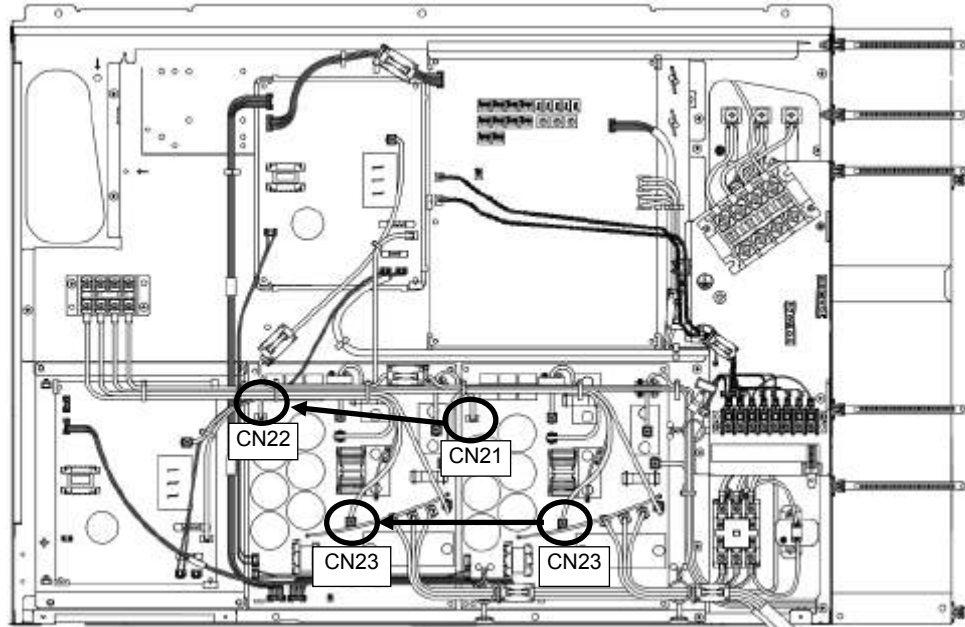

Change the connection of wiring which is connected to the CN21, 23 of Comp-IPDU2

- Change to CN22 of Comp-IPDU1 from CN21 of Comp-IPDU2
- Change to CN23 of Comp-IPDU1 from CN23 of Comp-IPDU2
(Tighten two wirings together with screw terminal)

9-3. Outdoor Unit Backup Operation Setting

<Outline>

This product allows outdoor unit backup operation setting to be performed either at the header unit or a follower unit. If any of the fault modes specified below occurs to one of the outdoor units in a multi-outdoor unit system, proceed with outdoor unit backup operation.

- A compressor failure (e.g. a layer short-circuit or a compressor failure in which no compressor is available to back up the faulty compressor)
- A failure of a pressure sensor (PD or PS) or a temperature sensor (TD1, TD2, TS1, TS2, TE1, TE2, TK1, TK2, TK4, TK5 or TL1)

Note: Keep the number of backed-up outdoor units to one in the system (single refrigerant line).

9-3-1. Follower outdoor unit backup operation setting (failure of follower outdoor unit)

<Work procedure>

(1) Turn off the power supply to all the indoor and outdoor units connected to the system.

[Setup of failed follower outdoor unit]

(2) Fully close the gas pipe service valve of the failed outdoor unit.

(3) Leave the service valves of the liquid and balance pipe fully open (to prevent refrigerant stagnation in the unit). However, if there is a leakage from an outdoor PMV (unable to close), fully close the liquid pipe service valve.

(4) <In case of fault in compressor, electrical part, I/F P.C. board, or IPDU P.C. board>

From this point on, keep the power supply to the failed unit off.

<In case of fault in refrigerating circuit or related part (pressure sensor, temperature sensor, refrigerating cycle part, or fan system part)>

Disconnect the connector [CN03] for outdoor-outdoor communication (BUS2) provided on the interface P.C. board.

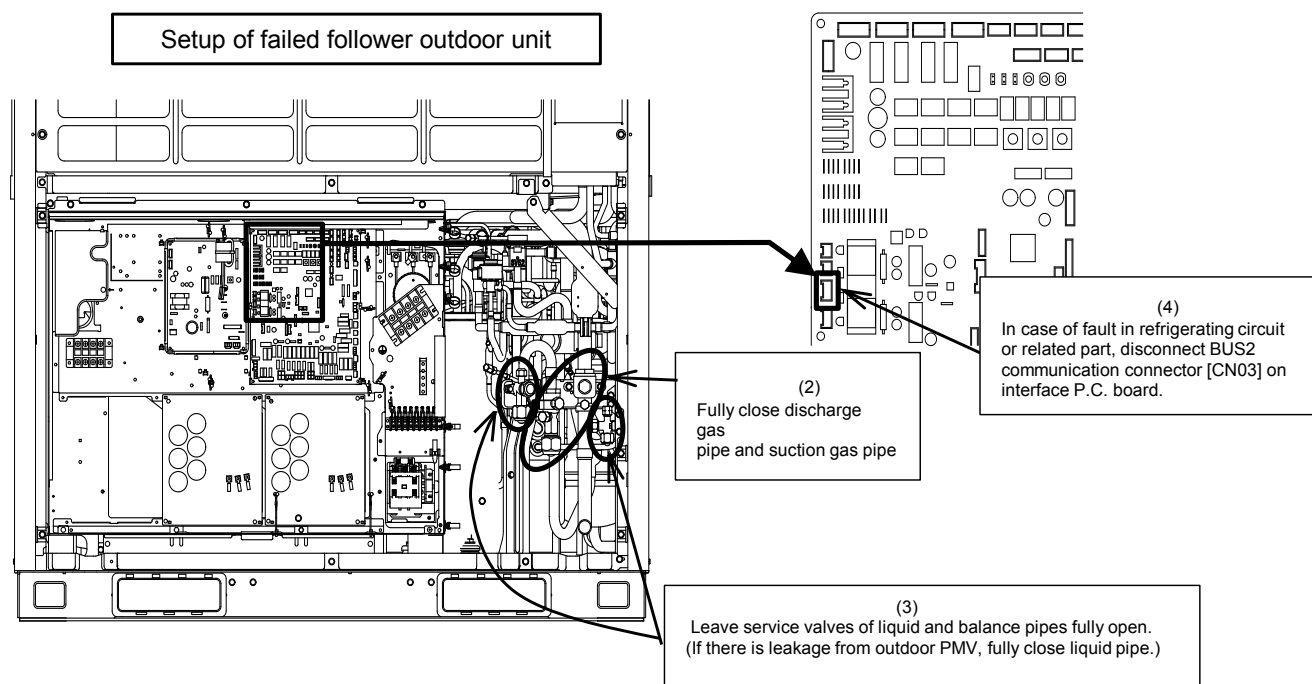

[Setup of header unit]

(5) Turn on Bit 2 of SW09 on the interface P.C. board of the header unit.
 (Setting to prevent connected indoor units capacity over trouble. (E16))

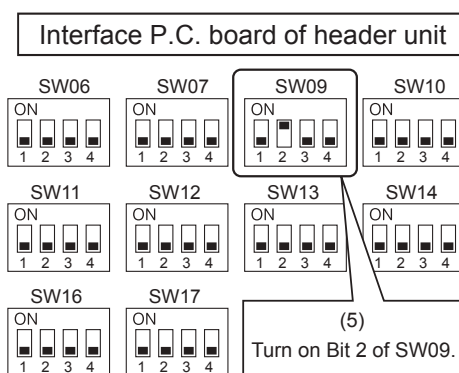

- (6) Turn on the power supply to all the units connected to the system other than the failed follower unit. Determine what to do with the power supply to the failed follower unit in the following manner.
- <In case of fault in compressor, electrical part, I/F P.C. board, or IPDU P.C. board>
 Leave the power supply off.
 - <In case of fault in refrigerating circuit or related part (pressure sensor, temperature sensor, refrigerating cycle part, or fan system part)>
 Turn on the power supply to protect the compressor (by turning on the case heater).
- (When the power supply to the unit is turned on, [E19] (trouble in the number of outdoor header units) will be displayed on the 7-segment display. However, this will not cause any problems.)
- (7) Perform settings needed to gain permission for backup operation from the header unit (trouble clearance).
- 1) Set SW01/02/03 on the interface P.C. board to 1/1/1 and confirm that [U1] [E26] (dropping out of an outdoor unit) is displayed on the 7-segment display.
 - 2) Set SW01/02/03 on the interface P.C. board to 2/16/1. Upon confirming that [Er] [... ..] is displayed on the 7-segment display, press SW04 and hold for 5 seconds or more.
 - 3) [Er] [... CL] (trouble clearance completed) will be displayed on the 7-segment display.
 - 4) Set SW01/02/03 back to 1/1/1. (The display should change to [U1] [- - -].)

- (7)
 Set SW01/02/03 to 1/1/1
 [U1] [E26] will be displayed.
 ↓
 Set SW01/02/03 to [2/16/1].
 [Er] [... ..] will be displayed.
 ↓
 Press SW04 and hold for 5 seconds or more
 [Er] [... CL] will be displayed.
 ↓
 Set SW01/02/03 back to 1/1/1.
 [U1] [- - -] will be displayed.

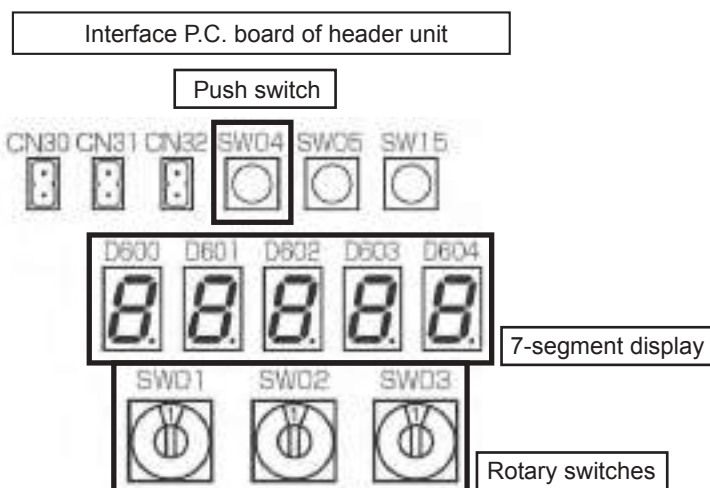

This is the end of follower outdoor unit backup operation setting. Check the operation.

9-3-2. Header outdoor unit backup operation setting (failure of header outdoor unit)

<Work procedure>

(1) Turn off the power supply to all the units connected to the system at the source.

[Setup of failed header outdoor unit]

(2) Fully close the discharge gas pipe and suction gas pipe service valve of the failed outdoor unit.

(3) Leave the service valves of the liquid and balance pipes fully open (to prevent refrigerant stagnation in the failed outdoor unit).

However, if there is a leakage from an outdoor PMV (unable to close), fully close the liquid pipe service valve.

(4) <In case of fault in compressor, electrical part, I/F P.C. board, or IPDU P.C. board>

From this point on, keep the power supply to the failed unit off.

<In case of fault in refrigerating circuit or related part (pressure sensor, temperature sensor, refrigerating cycle part, or fan system part)>

Disconnect the connector [CN03] for outdoor-outdoor communication (BUS2) provided on the interface P.C. board.

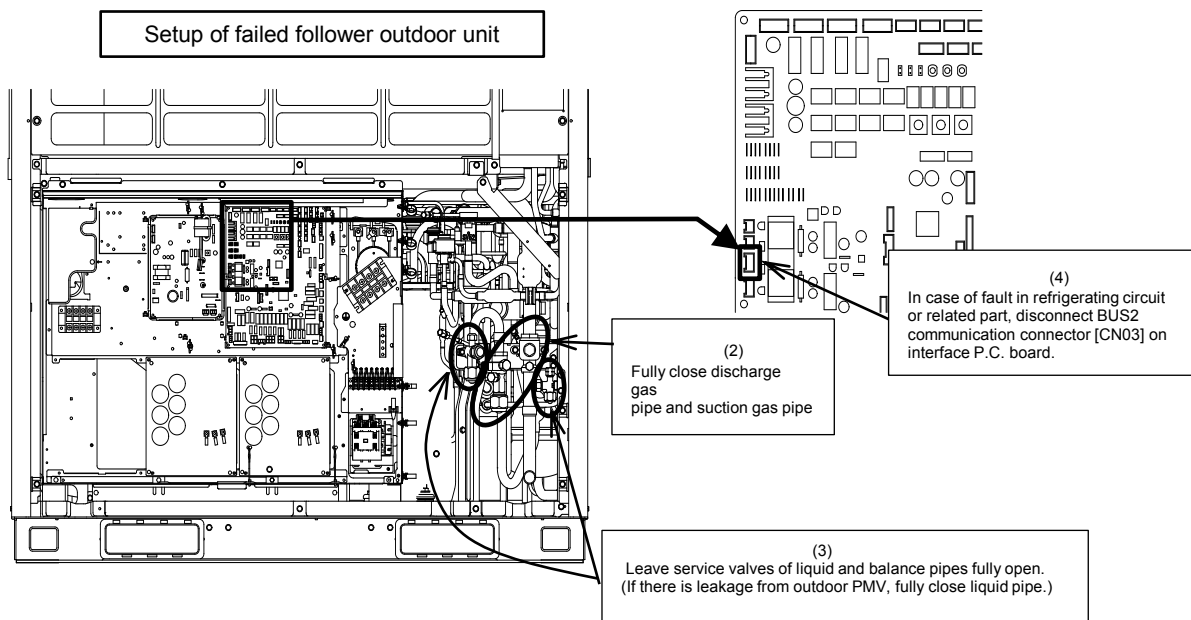

[Selection of new header unit]

(5) Select a new header unit from the follower units on the basis of the following criteria:

- If only one follower unit is connected, select it as the header unit.
- If two follower units are connected, select the follower unit that is nearest to the failed header unit.

[Setup of new header unit]

(6) Set SW13 and SW14 on the interface P.C. board same as the setting of failed header unit (refrigerant line address setting).

(7) Turn on Bit 2 of SW09 on the interface P.C. board. (Setting to prevent connected indoor unit capacity over trouble. (E16))

(8) Set Bits 1 and 2 of SW30 on the interface P.C. board same as that of the failed header unit (terminator resistance setting).

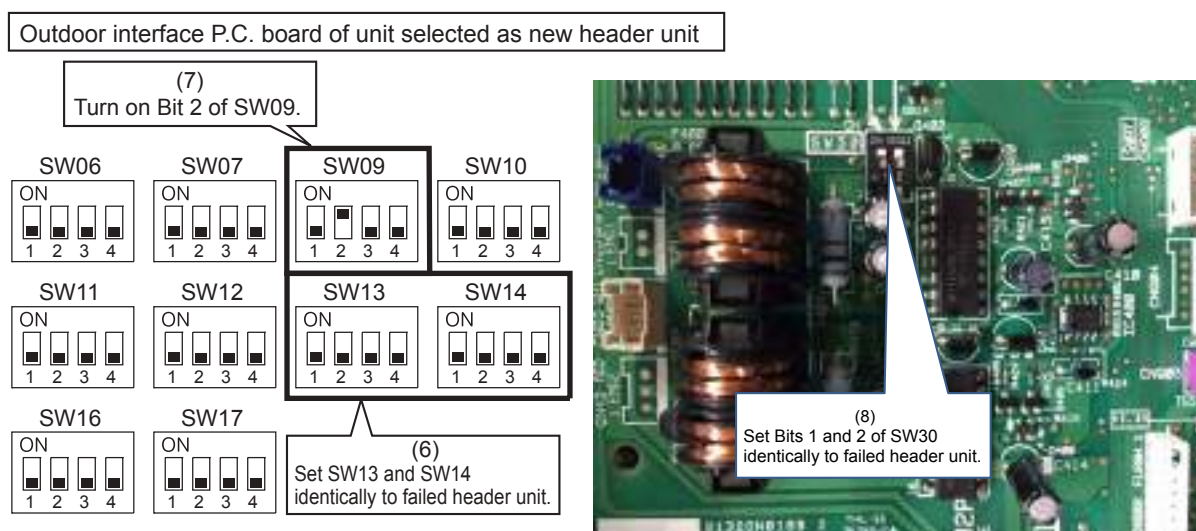

[Wiring changes to communication line]

(9) Redirect the indoor-outdoor communication line connected to the failed header unit [U1/U2] to the unit selected as the header unit [U1/U2].

(10) If a central control device is connected, connect the central control communication line [U3/U4] to the communication line terminal of the unit selected as the new header unit [U3/U4], and connect up the tie connector between the [U1/U2] and [U3/U4] terminals.

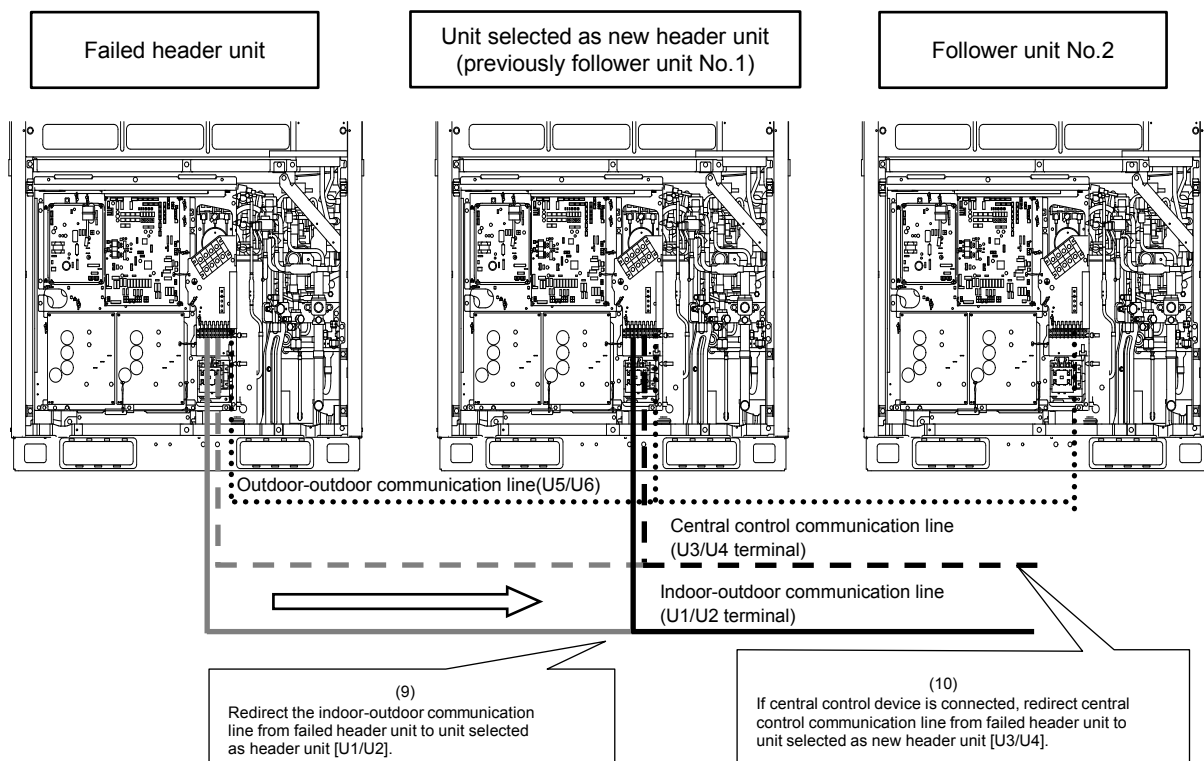

(11) Turn on the power supply to all the units connected to the system other than the failed unit.

Determine what to do with the power supply to the failed unit in the following manner.

<In case of fault in compressor, electrical part, I/F P.C. board, or IPDU P.C. board>

Leave the power supply off.

<In case of fault in refrigerating circuit or related part (pressure sensor, temperature sensor, refrigerating cycle part, or fan system part)>

Turn on the power supply to protect the compressor (by turning on the case heater).

(When the power supply to the unit is turned on, [E19] (trouble in the number of outdoor header units) will be displayed on the 7-segment display. However, this will not cause any problems.)

This is the end of header outdoor unit backup operation setting. Check the operation.

10 OUTDOOR UNIT REFRIGERANT RECOVERY METHOD

10-1. Refrigerant Recovery from Failed Outdoor Unit (Pump-Down)

This product supports refrigerant pump-down, a function which allows refrigerant to be recovered from an outdoor unit in need of repair using a normal outdoor unit in a system featuring multiple outdoor units.

10-1-1. Note for refrigerant recovery operation

When performing pump-down operation, take note of the following matters:

- Note 1:** The pump-down refrigerant recovery rate changes with outside temperature and other factors. After pump-down is completed, recover any residual gas using a refrigerant recovery device, etc., and be sure to measure the amount of recovered refrigerant. (The refrigerant recovery rate can be improved by heating the accumulator of the outdoor unit to be repaired during pump-down operation.)
- Note 2:** If pump-down has been performed, the system cannot be operated until the faulty outdoor unit is repaired. (Continued operation would be impossible due to a refrigerant overcharge.)
- Note 3:** If outdoor PMV1 happen to be troubled (unable to open) or PMV4 fails while fully closed, the refrigerant in the heat exchangers (or sub-heat exchangers) cannot be recovered. In that case, recover any residual gas in the heat exchangers (or sub-heat exchangers) using a tube piercing valve or some other tool. After a pump-down operation, do not perform any brazing until the residual gas in the heat exchangers is recovered.

10-1-2. Refrigerant recovery procedure A (Case of no outdoor unit backup operation setting)

<Work procedure>

Turn on the power supply to the system at the source, but leave the system switched off.

If the trouble involves poor insulation of a compressor motor, remove the motor leads before the power is turned on.

[Setup of failed outdoor unit]

- (1) Connect the check joint of liquid pipe and the low pressure-side check joint using a charge hose, and purge the hose of air (to recover refrigerant from the liquid tank and heat exchangers).
- (2) Fully close the liquid pipe service valve of the failed outdoor unit. (Leave the service valves of the gas and balance pipes fully open.)
- (3) If the oil is likely to have degraded due to a compressor trouble, disconnect the SV3A valve connector of the failed outdoor unit (to prevent the degraded oil from flowing into other outdoor units).
- (4) Set SW01/02/03 on the interface P.C. board of the failed outdoor unit to 2/11/1. After [rd] [... ..] is displayed on the 7-segment display, press SW04 and hold for 5 seconds or more.

(5) [rd] [... FF] will be displayed on the 7-segment display, and pump-down operation will start.

* To put the operation on hold midway, turn off the power supply to all the outdoor units, or press SW05 on the interface P.C. board.

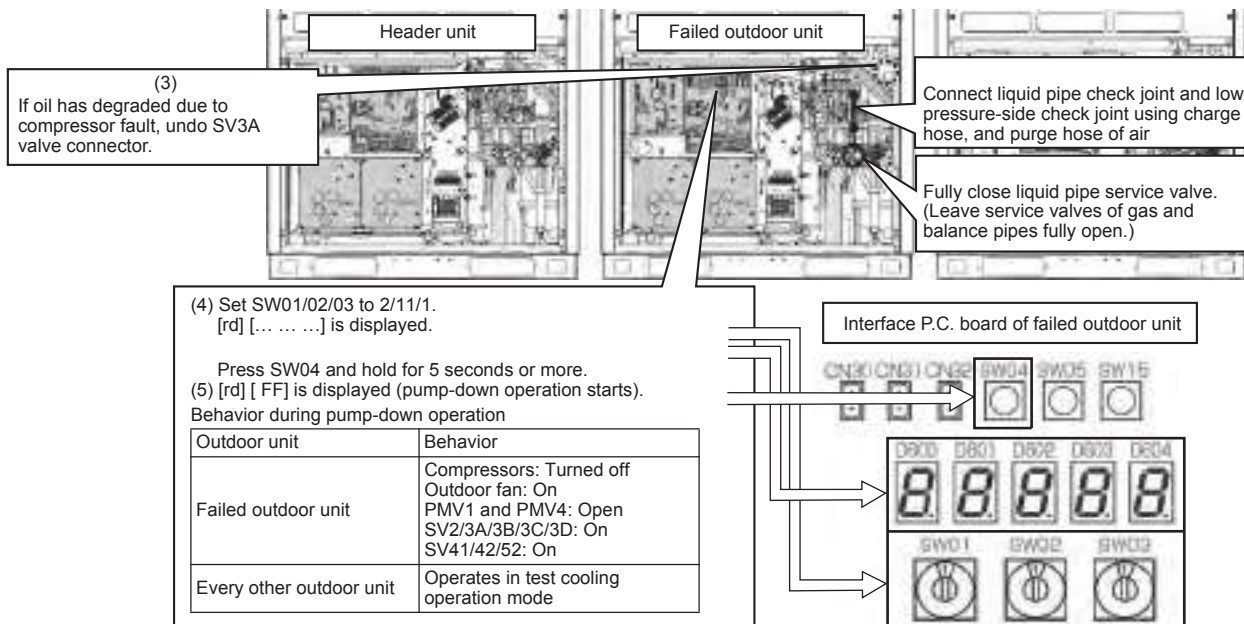

(6) Approx. 10 minutes after the system starts up, fully close the gas pipe service valve of the failed outdoor unit.

(7) Press SW04 of the failed outdoor unit to have pressure data (MPa) displayed.

(The display switches each time SW04 is pressed.)

Display Example

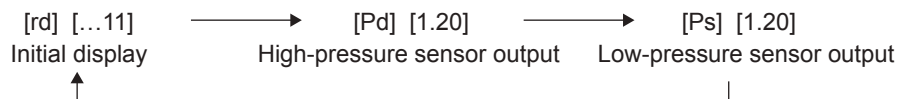

[Selection of outdoor unit for pressure adjustment]

(8) Of all outdoor units operating in the pump-down mode, select the one with the lowest unit No. as an outdoor unit for pressure adjustment.

Identifying Unit No.

The unit No. is the number displayed on the 7-segment display when SW01/02/03 are set to 1/1/1.

([U#] [- - -]: # represents the unit No.)

[Setup of outdoor units other than unit for pressure adjustment and failed unit]

(9) Leaving the balance pipes of the unit for pressure adjustment and the failed unit fully open, fully close the balance pipe service valves of all other outdoor units.

[Setup of outdoor unit for pressure adjustment]

(10) Set SW01/02/03 on the interface P.C. board of the outdoor unit for pressure adjustment to 1/2/2.

(11) As the low-pressure sensor output is displayed on the 7-segment display, adjust the pressure to around 0.12 MPa by slowly closing the gas pipe service valve, with checking pressure data.

(12) Compare the low-pressure sensor outputs of the failed unit with that of the unit for pressure adjustment, and wait until the two pressure readings become almost the same. After letting the system continue operating for a while longer, fully close the gas pipe service valve of the unit for pressure adjustment.

[Setup of failed outdoor unit]

- (13) When the low-pressure sensor output of the failed outdoor unit falls below 0.10MPa, fully close the balance pipe packed valve, and press SW05 on the interface P.C. board to finish the pump-down operation.
- (14) Turn off the power supply to all the outdoor units, and recover the residual refrigerant in the outdoor unit using a refrigerant recovery device. Be sure to measure the amount of recovered refrigerant. (This is necessary to determine how much additional refrigerant will be needed after the completion of the repair.)

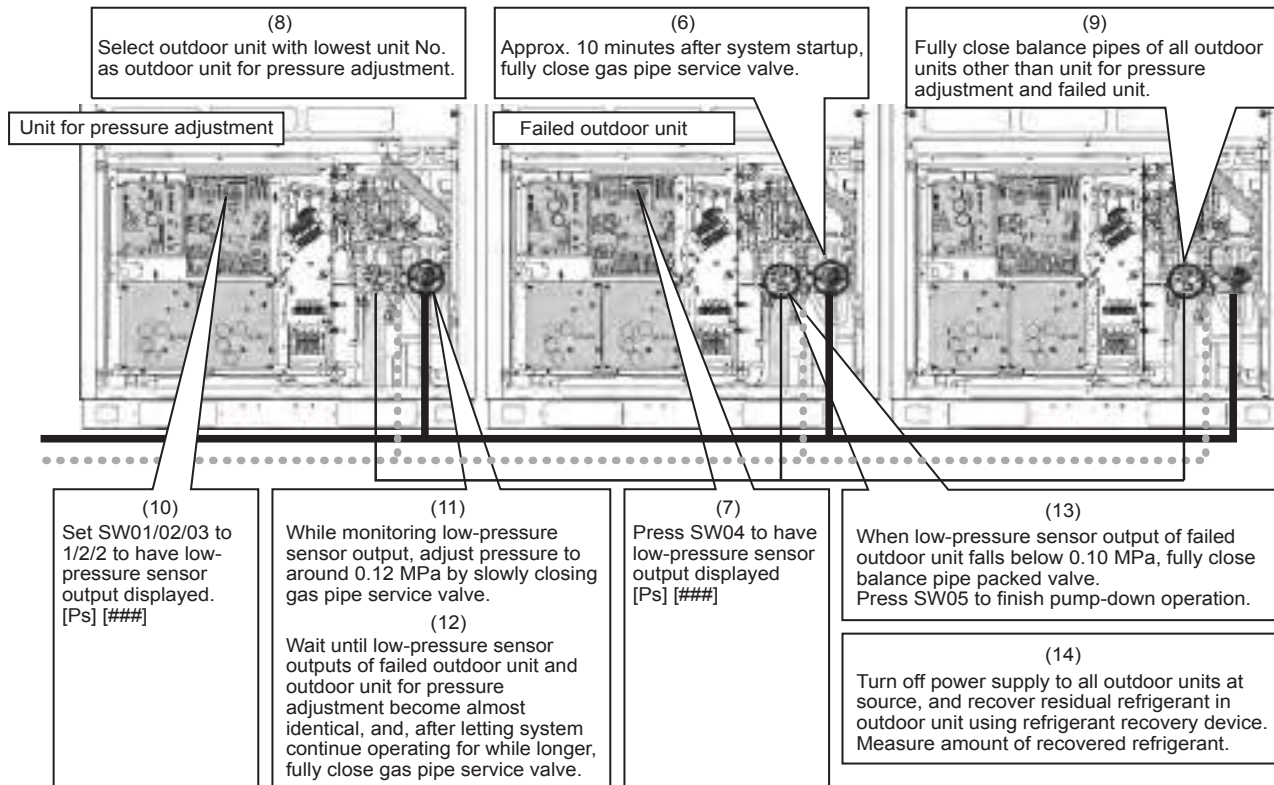

This is the end of the refrigerant recovery operation.

Set SW01/02/03 of the failed outdoor unit and the outdoor unit for pressure adjustment back to 1/1/1.

10-1-3. Refrigerant recovery procedure B (Case of outdoor unit backup operation setting)

<Outline>

If outdoor unit backup operation setting is performed, use an alternative refrigerant recovery procedure as described below, provided that the power cannot be turned on for the failed outdoor unit. (Refrigerant will be recovered from the failed outdoor unit using the test cooling operation function.)

Note 1: If cooling-season outdoor unit backup operation or outdoor unit backup operation is in progress with the power supply to the failed outdoor unit turned on, follow the procedure described in “10-1-2. Refrigerant recovery procedure A (Case of no outdoor unit backup operation setting)”. If outdoor unit backup operation setting is performed with the power supply to the failed outdoor unit turned on, recovery operation can only start after putting the outdoor-outdoor communication connector on the interface P.C. board of that unit [CN03] back to its initial state and resetting the power supply.

Note 2: If the power cannot be turned on the failed outdoor unit, the solenoid valves and PMVs of the unit cannot be turned on, so that it reduces the amount of recovered refrigerant compared to a standard pump-down operation. Recover the residual gas in the unit using a refrigerant recovery device, and be sure to measure the amount of recovered refrigerant.

<Work procedure>

[Setup of failed outdoor unit]

- (1) Connect the liquid pipe check joint and the low pressure-side check joint using a gauge manifold, and purge the manifold of air (to recover refrigerant from the liquid tank and heat exchangers).
- (2) Fully close the liquid pipe packed valve of the failed outdoor unit.
(Leave the service valve of the gas pipe and the packed valve of the balance pipe fully open.)

[Setup of unit selected as header unit (hereafter “header outdoor unit”)]

- (3) Set SW01/02/03 on the interface P.C. board of the header outdoor unit to 2/5/1. After [C.] [... ..] is displayed on the 7-segment display, press SW04 and hold for 5 seconds or more.
- (4) After [C. ...] [... – C] is displayed on the 7-segment display, the system starts operating in the test cooling operation mode.
- (5) Set SW01/02/03 on the interface P.C. board of the header outdoor unit to 1/2/2 to have the low-pressure sensor output (MPa) displayed on the 7-segment display.

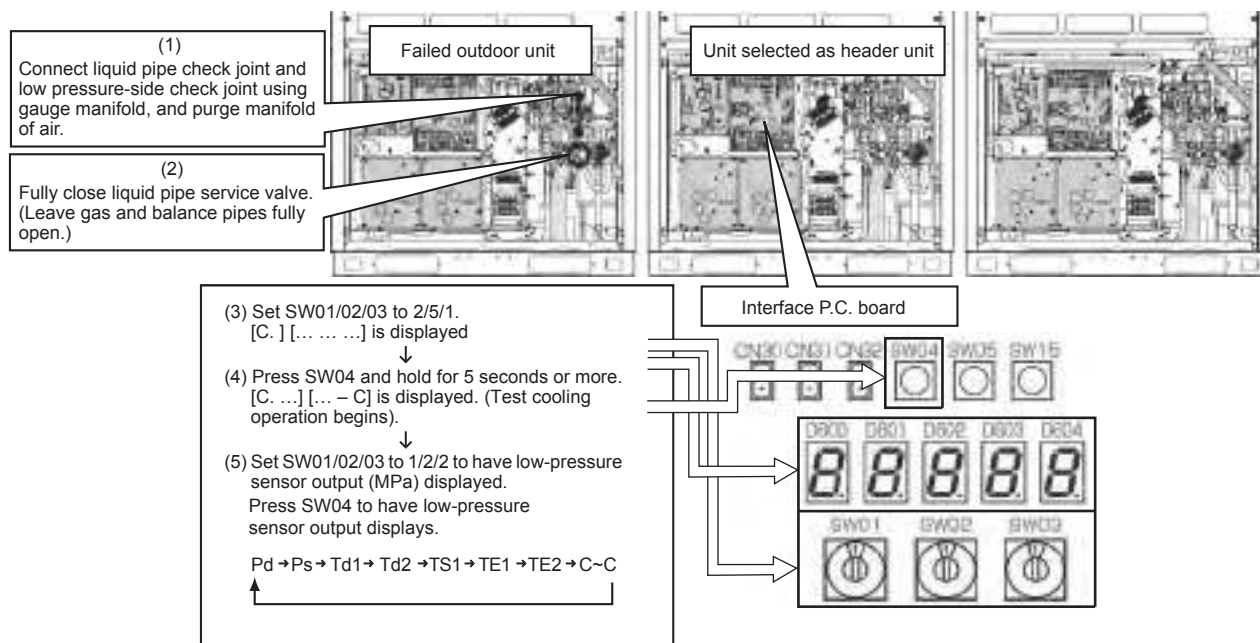

- (6) Approx. 10 minutes after the system starts up, fully close the gas pipe service valve of the failed outdoor unit.

[Selection of outdoor unit for pressure adjustment]

- (7) Select the header unit as the unit for pressure adjustment.

[Setup of outdoor units other than header unit and failed unit]

(8) Leaving the balance pipes of the unit for pressure adjustment and the failed unit fully open, fully close the balance pipe packed valves of all other outdoor units.

[Setup of header unit]

(9) While monitoring the low-pressure sensor output, adjust the pressure to around 0.12 MPa by slowly closing the gas pipe service valve.

(10) Compare the manifold gauge pressure of the failed unit with the low-pressure sensor output of the header unit, and wait until the two pressure readings become almost identical. After letting the system continue operating for a while longer, fully close the gas pipe service valve of the unit for pressure adjustment.

[Setup of failed outdoor unit]

(11) When the manifold gauge pressure of the failed outdoor unit falls below 0.10 MPa, fully close the balance pipe packed valve, and press SW05 on the interface P.C. board to finish the test cooling operation.

(12) Turn off the power supply to all the outdoor units, and recover the residual refrigerant in the outdoor unit using a refrigerant recovery device. Be sure to measure the amount of recovered refrigerant. (This is necessary to determine how much additional refrigerant will be needed after the completion of the repair.)

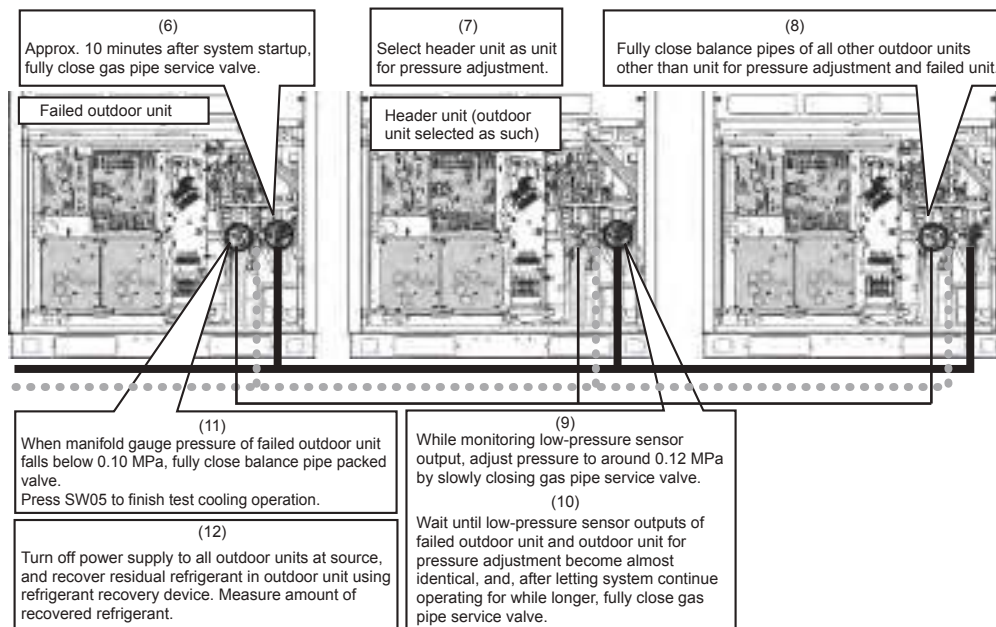

This is the end of the refrigerant recovery operation.
Set SW01/02/03 of the header unit back to 1/1/1.

10-2. How to Operate System While Failed Outdoor Unit Being Repaired

<Outline>

After refrigerant is recovered from the failed outdoor unit through a pump-down operation, the overall amount of refrigerant held by the system becomes excessive, and this makes it impossible to operate the remaining outdoor units even though they are not troubled. However, operation is still possible if the system-wide amount of refrigerant is adjusted in accordance with the procedure described below.

<Work procedure>

- (1) Follow the steps specified in “10-1. Refrigerant Recovery from Failed Outdoor Unit (Pump-Down)”.
- (2) Adjust the amount of refrigerant held by the system by removing some of it using a refrigerant recovery device, etc.

Determine the amount of refrigerant to be removed according to the capacity of the failed outdoor unit. (See the table below.)

Example: If a 18HP outdoor unit is under repair in a 50HP system:

Amount of refrigerant required by system as it was initially (50HP in capacity)=51.0kg

Amount of refrigerant required by system with available outdoor units only (32HP in capacity)=37.0kg

Amount of refrigerant to be removed from system =51.0-37.0=14kg

- (3) Set up the outdoor unit from which refrigerant has been recovered in the manner described in “9-3. Outdoor Unit Backup Operation Setting”.

This completes the procedure.

System capacity (HP)	Combined outdoor units (HP)			Amount of refrigerant (kg)
8	8			13.0
10	10			14.0
12	12			19.0
14	14			21.0
16	16			23.0
18	18			25.0
20	20			26.0
22	12	10		28.0
24	14	10		30.0
26	14	12		34.0
28	14	14		34.0
30	16	14		36.0
32	18	14		37.0
34	18	16		38.0
36	18	18		40.0
38	20	18		44.0
40	20	20		46.0
42	14	14	14	47.0
44	16	14	14	48.0
46	18	14	14	49.0
48	18	16	14	50.0
50	18	18	14	51.0
52	18	18	16	53.0
54	18	18	18	55.0

* MMY-***FT8(J)P-UK capacity range is from 8HP to 42HP.

10-3. Work procedure after Repair

When vacuuming in the repaired outdoor unit, follow the procedure described below.

<Work procedure>

(1) Fully open PMV1 and PMV4 in accordance with the table below.

Note: PMV full-opening operation via short-circuiting of the CN30 pins is automatically undone after 2 minutes, causing the valves to fully close. To maintain fully open state, turn off the power switch of the outdoor unit within 2 minutes of the short-circuiting of the CN30 pins.

SW12				CN30	PMV operation
Bit 1	Bit 2	Bit 3	Bit 4		
OFF	OFF	OFF	OFF	Short-circuit	PMV1 fully open for 2 minutes.
ON	OFF	OFF	OFF	Short-circuit	PMV4 fully opens for 2 minutes.

(2) Be sure to perform vacuuming in from the three check joints shown in the diagram below (liquid pipe, discharge pipe and suction pipe).

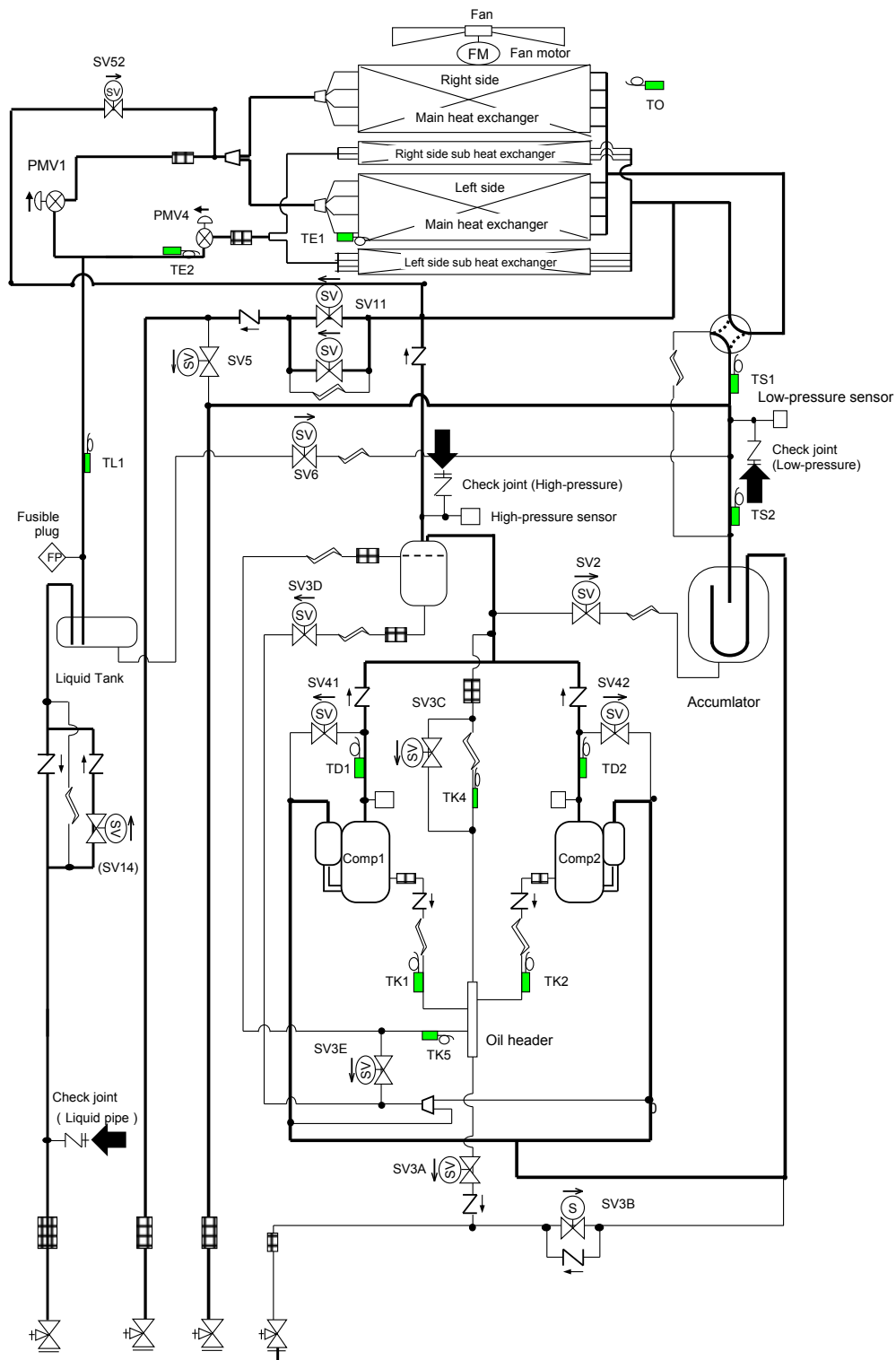

11 REPLACING COMPRESSORS

11-1. Compressor Replacement Procedure (Outline)

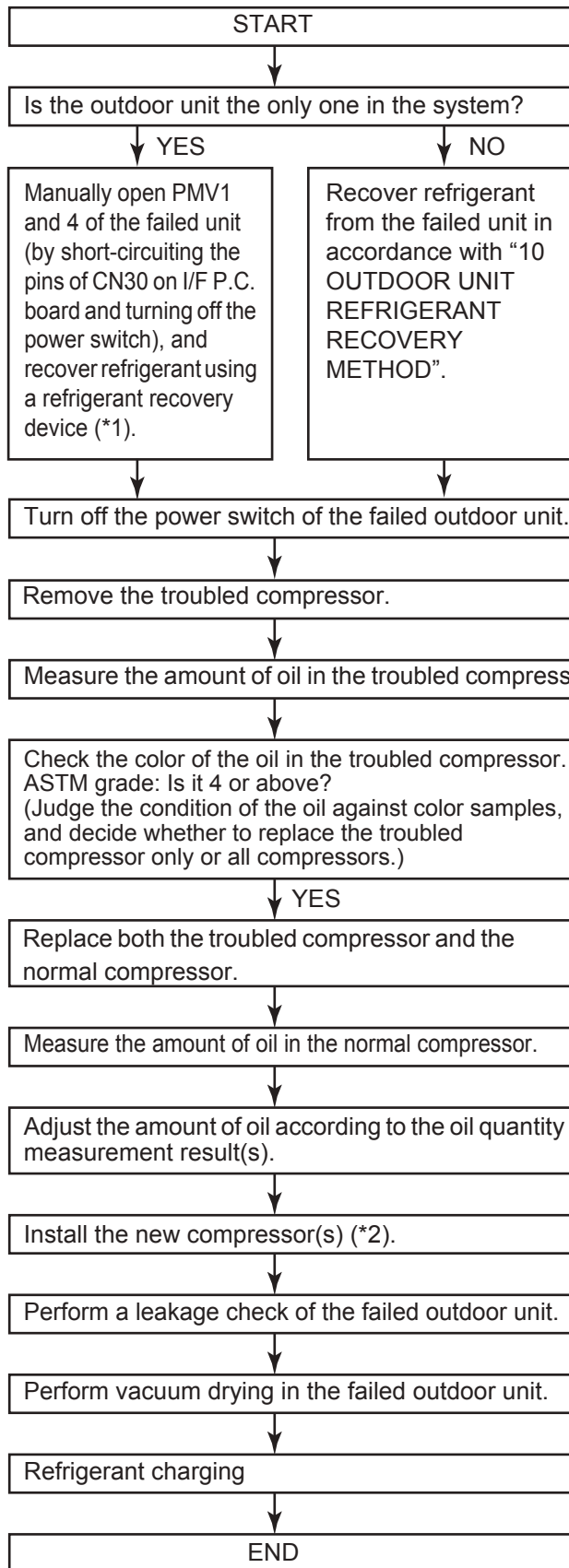

⚠ WARNING

In situations such as indoor unit relocation and repairs, it is not possible to recover all the refrigerant held by the system in the outdoor units. It could cause a serious accident, such as blow out or injury. Be sure to perform refrigerant recovery using a refrigerant recovery device.

⚠ WARNING

When detaching a pipe by heating with a burner at brazed joint, take care as any oil left in the piping may burn in a momentary flash of fire when the brazed filler metal melts.

*1 The full-opening of PMV1 and 4 via short-circuiting of the CN30 pins is automatically undone after 2 minutes, causing the valves to fully close. To maintain fully open state, turn off the power switch of the outdoor unit within 2 minutes.

*2 The SHRM-e (6 series) and the SHRM-i (4 series) use different types of compressors. Be sure to check the service part code.

This flowchart only shows the standard compressor replacement procedure. Since the situation can differ site by site, perform the task in accordance with the following judgment criteria:

- (1) New compressors are charged with 1900cc of oil per unit.
- (2) The amount of oil held by an outdoor unit is as shown below.

Model MAP-	0806*,1006*	1206*,1406*, 1606*, 1806*, 2006*
Amount of oil [cc]	4300	4800

- (3) When a compressor is dismantled, it usually contains 800-1400cc oil. The amount of oil held by an oil separator is usually 0-1000cc for MAP0806*, MAP1006*, MAP1206*, MAP1406*, MAP1606*, MAP1806* and MAP2006*

11-2. Replacement of Compressors

<Checking color of oil in troubled compressor>

- Lay the faulty compressor down, draw a small amount of oil via the oil equalization pipe, and check its color against color samples.
- Determine the number of compressors to be replaced according to the color checking result.
 ASTM grade: Below 4 → Replace the troubled compressor only.
 ASTM grade: 4 or above → Replace both the troubled compressor and the normal compressor(s).

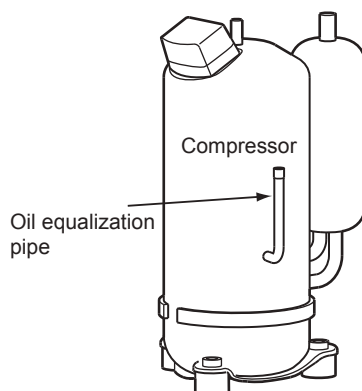

WARNING

When detaching a pipe by heating with a burner at brazed joint, take care as any oil left in the piping may burn in a momentary flash of fire when the brazing filler metal melts.

[When replacing troubled compressor only]

<Measuring amount of oil in troubled compressor>

Amount of oil in troubled compressor: $A \text{ [cc]} = (\text{Weight of compressor as it was dismantled (kg)} - D) \times 1042$ (Specific volume of oil: 1042 [cc/kg])

(kg)

Compressor model	D : Weight (not include oil)
RA641A3TB-20M	23.6
RA421A3TB-20MD	21.9

※Please check the type name of the compressor as it was dismantled.

<Adjusting amount of oil in new compressor> (1900cc at shipment)

- Perform the adjustment on the basis of how much oil the troubled compressor contained, A [cc], by following the steps below.

1 Amount of oil in faulty compressor A [cc]: $0 \leq A < 1000$

(1) Adjust the amount of oil in the new compressor to 1000cc.

(Lay the new compressor down and draw 900 [cc] of oil via the oil-equalization pipe.)

Notes:

- Do not draw more than 900 [cc] of oil as it may cause damage to the compressor.
- If the troubled compressor contained 500cc or less, there may have been a problem with the oil equalization circuit, etc. Perform checks in accordance with "11-3. Check Procedure to Search Cause of Compressor Oil Shortage".

2 Amount of oil in troubled compressor A [cc]: $1000 \leq A < 1900$

- (1) Adjust the amount of oil in the new compressor to A cc.
(Lay the new compressor down and draw $(1900 - A)$ [cc] of oil via the oil equalization pipe.)

3 Amount of oil in troubled compressor A [cc]: $1900 \leq A$

- (1) Adjust the amount of oil in the new compressor to A cc.
(Insert a hose into the discharge pipe or oil equalization pipe of the new compressor and inject $(A - 1900)$ [cc] of oil using a funnel, etc.)

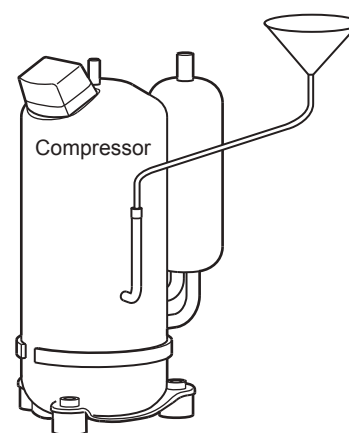

[When replacing normal as well as troubled compressor] - applicable to MMY-MMP0806* and 1006*

<Remove the normal compressor>

- Remove the normal compressor in the same way as the troubled compressor.

Note:

- Be sure to insulate the removed compressor leads using insulation tape, etc.

⚠ WARNING

When detaching a pipe by heating with a burner at brazed joint, take care as any oil left in the piping may burn in a momentary flash of fire when the brazing filler metal melts.

<Measuring amount of oil in normal compressor>

- As was the case with the troubled compressor, measure the amount of oil contained by placing the compressor on a scale.

Amount of oil in normal compressor: $B \text{ [cc]} = (\text{Weight of compressor as it was dismantled (kg)} - D) \times 1042$
(Specific volume of oil: 1042 [cc/kg])

Note:

Compressor model	D : Weight (not include oil)
RA421A3TB-20MD	21.9

(kg)

※Please check the type name of the compressor as it was dismantled.

<Adjusting amount of oil in new compressors>

- Perform the adjustment on the basis of how much oil the troubled compressor contained, A [cc], and how much oil the normal compressor contained, B [cc], by following the steps below.

1 Combined amount of oil in troubled and normal compressors A+B [cc]: $0 \leq A+B < 2000$

(1) Adjust the amount of oil in the two new compressors to 1000cc each (total 2000cc).

- Lay the compressors down and draw 900 [cc] of oil from each of them via their oil equalization pipes.

Notes:

- Do not draw more than 900 [cc] of oil from a compressor as it may cause damage.
- If troubled compressor contained 500cc or less, there may have been a problem with the oil equalization circuit, etc. Perform checks in accordance with “11-3. Check Procedure to Search Cause of Compressor Oil Shortage”.

2 Combined amount of oil in troubled and normal compressors A+B [cc]: $2000 \leq A+B < 4300$

(1) Adjust the amount of oil in the two new compressors to $(A+B)/2$ cc each.

- Lay the compressor down and draw $[4300-(A+B)]/2$ [cc] of oil from each of them via their oil equalization pipes.

3 Combined amount of oil in troubled and normal compressors A+B [cc]: $4300 \leq A+B$

(1) Adjust the amount of oil in the two new compressors to $(A+B)/2$ cc each.

(Insert a hose into the discharge pipe or oil equalization pipe of each compressor and inject $(A+B)/2-1900$ [cc] of oil using a funnel, etc.)

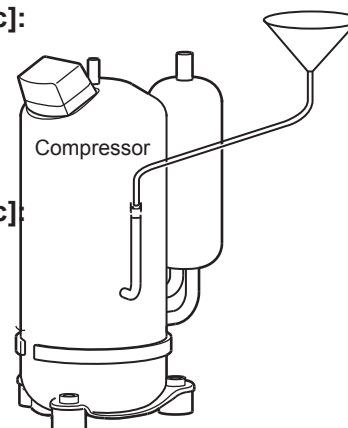

[When replacing normal as well as faulty compressor] - applicable to MMY-MAP1206*, 1406*, 1606*, 1806* and 2006*

<Remove the normal compressor>

- Remove the normal compressor in the same way as the troubled compressor.

Note:

- Be sure to insulate the removed compressor leads using insulation tape, etc.

⚠ WARNING

When detaching a pipe by heating with a burner at brazed joint, take care as any oil left in the piping may burn in a momentary flash of fire when the brazing filler metal melts.

<Measuring amounts of oil in normal compressor>

- As was the case with the troubled compressor, measure the amount of oil contained by placing each compressor on a scale.
Amount of oil in normal compressor: $B \text{ [cc]} = (\text{Weight of compressor as it was dismantled (kg)} - D) \times 1042$
(Specific volume of oil: 1042 [cc/kg])

Note:

Compressor model	D : Weight (not include oil)
RA641A3TB-20M	23.6

(kg)

※Please check the type name of the compressor as it was dismantled.

<Adjusting amount of oil in new compressors>

- Perform the adjustment on the basis of how much oil the troubled compressor contained, A [cc], and how much oil the normal compressor contained, B [cc], by following the steps below.

1 Combined amount of oil in troubled compressor and normal compressor A+B [cc]: $0 \leq A+B < 2000$

(1) Adjust the amount of oil in the two new compressors to 1000cc each (total 2000cc).

- Lay the compressors down and draw 900 [cc] of oil from each of them via their oil equalization pipes.

Notes:

- Do not draw more than 900 [cc] of oil from a compressor as it may cause damage.
- If the troubled compressor contained 500cc or less, there may have been a problem with the oil equalization circuit, etc. Perform checks in accordance with "11-3. Check Procedure to Search Cause of Compressor Oil Shortage".

2 Combined amount of oil in troubled compressor and normal compressor A+B [cc]: $2000 \leq A+B < 4800$

(1) Adjust the amount of oil in the two new compressors to $(A+B)/2$ cc each.

- Lay the compressor down and draw $[4800-(A+B)]/2$ [cc] of oil from each of them via their oil equalization pipes.

3 Combined amount of oil in troubled compressor and normal compressor A+B [cc]: $4800 \leq A+B$

(1) Adjust the amount of oil in the two new compressors to $(A+B)/2$ cc each (Insert a hose into the discharge pipe or oil equalization pipe of each compressor and inject $(A+B)/2-1900$ [cc] of oil using a funnel, etc.)

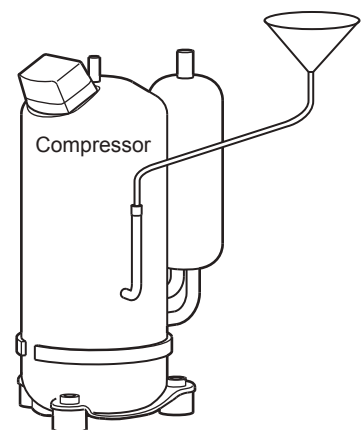

<Installing compressor>

- Install a compressor by following the dismantling procedure in reverse.
- The dismantling process may have loosened compressor leads and quick connectors. Prior to installation, therefore, tighten them a little with a pair of pliers, and verify that they are tight after reconnection.

Notes:

- Although a compressor is provided with only two hexagonal bolts, it is standard.
- The tightening torque of the hexagonal bolts, used to mount the compressor, is 200kg/cm.
- If oil has been drawn from the accumulator, repair the cut pipe through pinching and brazing.

<Vacuum-pumping>

(Single outdoor unit system)

- Before performing vacuum-pumping, fully open PMV1 and 4. If they are closed, the heat exchangers of the outdoor unit cannot be vacuum-pumped.
- Connect a vacuum pump consecutively to the check joints placed in the liquid and discharge pipes and on the high-pressure side of the suction pipe, and turn it on.
- Operate the vacuum drying until the vacuum gauge indicates 1 mmHg.

<Method to fully open PMV manually>

- (1) Turn on the power switch of the outdoor unit.
- (2) With the Bits 1 and 2 of SW12 set to off, short-circuit the pins of CN30.
- (3) Disconnect the connectors of PMV1 from the I/F P.C. board.
- (4) With the Bits 1 and 2 of SW12 set to off and on, respectively, short-circuit the pins of CN30.
- (5) Disconnect the connector of PMV4 from the I/F P.C. board
- (6) With the Bits 1 and 2 of SW12 set to on and off, respectively, short-circuit the pins of CN30.
- (7) Turn off the power switch of the outdoor unit.

Note: Steps (6) is not required for MMY-MAP0806* and 1006*.

<Refrigerant charging>

- Inject the same amount of refrigerant as the recovered residual refrigerant via the charging port of the liquid-side service valve.

11-3. Check Procedure to Search Cause of Compressor Oil Shortage

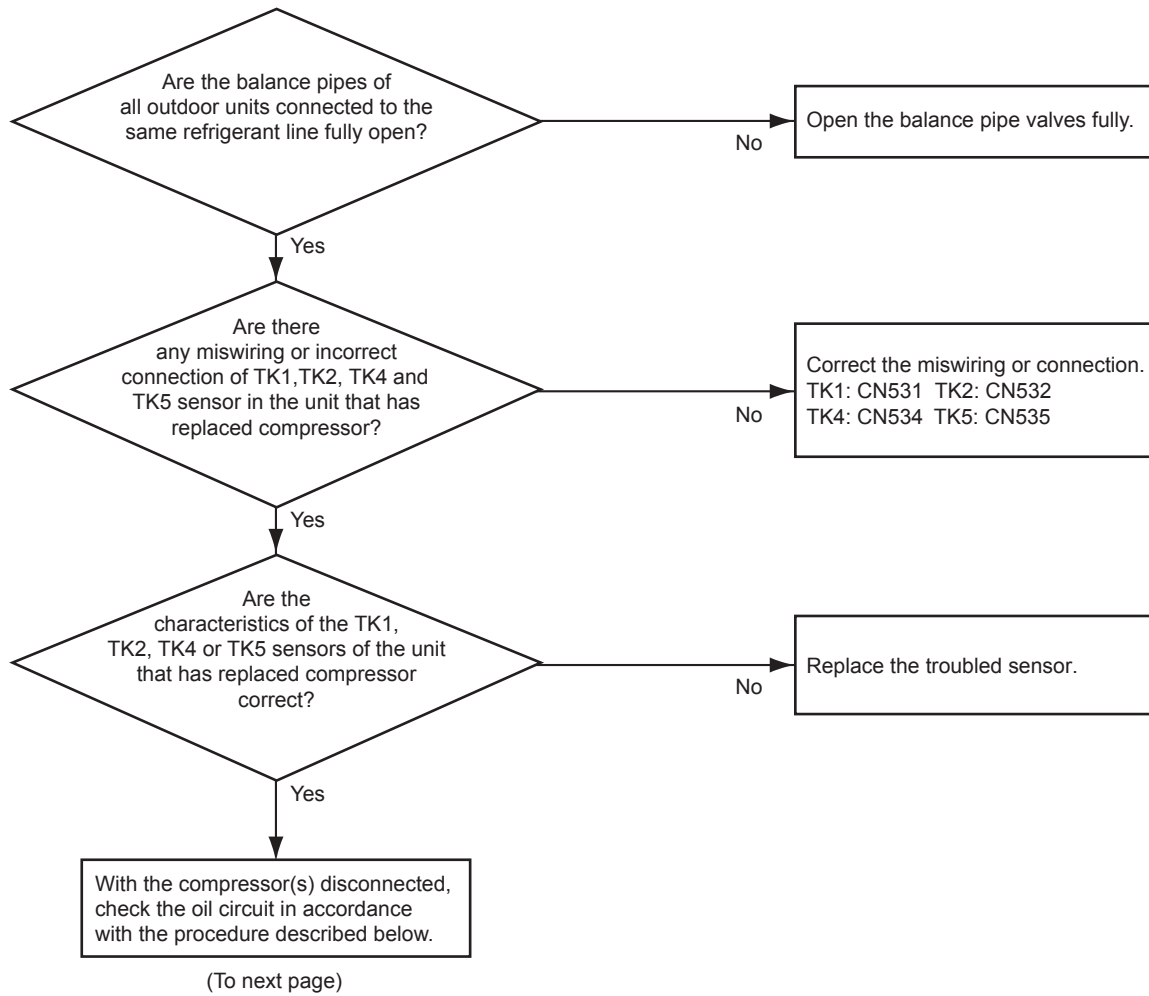

<MMY-MAP0806* and MAP1006*>

Check items and procedures to follow when checking oil circuit with compressor(s) disconnected

Check item	Location	Procedure
Leakage of outdoor PMV Leakage of check valve in discharge pipe convergent section	A,B,C	1) Pressure nitrogen from check joint of the liquid pipe under condition that PMV1 and 4 are fully closed, confirm the pressure using high-pressure check joint. If pressure of the high-pressure check joint rises, leakage from any of PMV1, 4 (A, B) and discharge check valve (C) is considered. Therefore replace all PMV1, 4 (A, B), discharge check valve (C). 2) If pressure did not rise, open PMV1 fully and then confirm pressure of the high-pressure check joint. When pressure was up, open fully PMV4 only and confirm pressure of the high-pressure check joint again. 3) When pressure was up, there is leakage from discharge check valve (C). Therefore replace them. If pressure did not rise, there is leakage from discharge check valve. Therefore replace them.
Leakage of check valve in discharge pipe	E	4) With pressure applied to the check joint of with nitrogen, if gas escapes from the discharge pipe section of the disconnected compressor, there is a leak from the check valve of discharge pipe (E). Replace the part.
Leakage of check valve in oil equalization circuit	F	5) With pressure applied to the check joint of with nitrogen, if gas escapes from the oil equalization pipe section of the disconnected compressor, there is a leak from the oil equalization pipe check valve (F). Replace the part.
Leakage of SV3A valve	G	6) With pressure applied to the check joint of with nitrogen, manually open the SV3B valve. If gas escapes from the suction pipe section of the disconnected compressor, there is a leak from the SV3A valve. Replace the part.
Leakage of SV3B valve	H	7) Then manually open the SV3A valve. If gas escapes from the suction pipe section of the disconnected compressor, there is a leak from the SV3B valve. Replace the part.
Clogging of SV3E valve Clogging of oil-return distributor	I	8) With pressure applied to the check joint of with nitrogen, manually open the SV3E valve. If gas does not escape from the suction pipe section of the disconnected compressor, the SV3E valve or oil-return distributor is clogged. Replace the part.
Clogging of SV3D valve Clogging of oil-return capillary Clogging of oil-return distributor	J	9) With pressure applied to the check joint of with nitrogen, manually open the SV3D valve. If gas does not escape from the suction pipe section of the disconnected compressor, the SV3D valve, oil-return capillary or oil-return distributor is clogged. Replace the part.

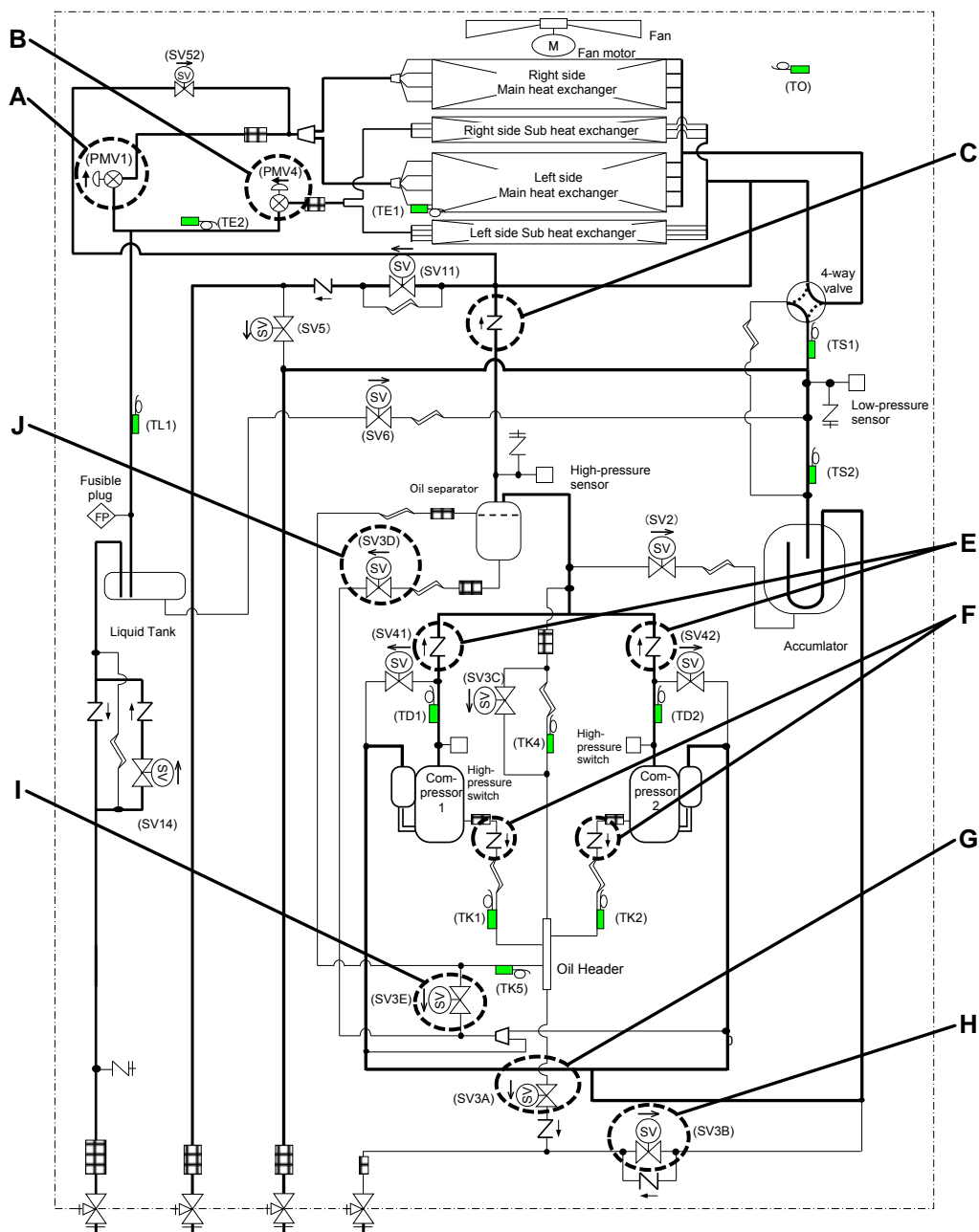



<MMY-MAP1606*, MAP1806* and MAP2006*>



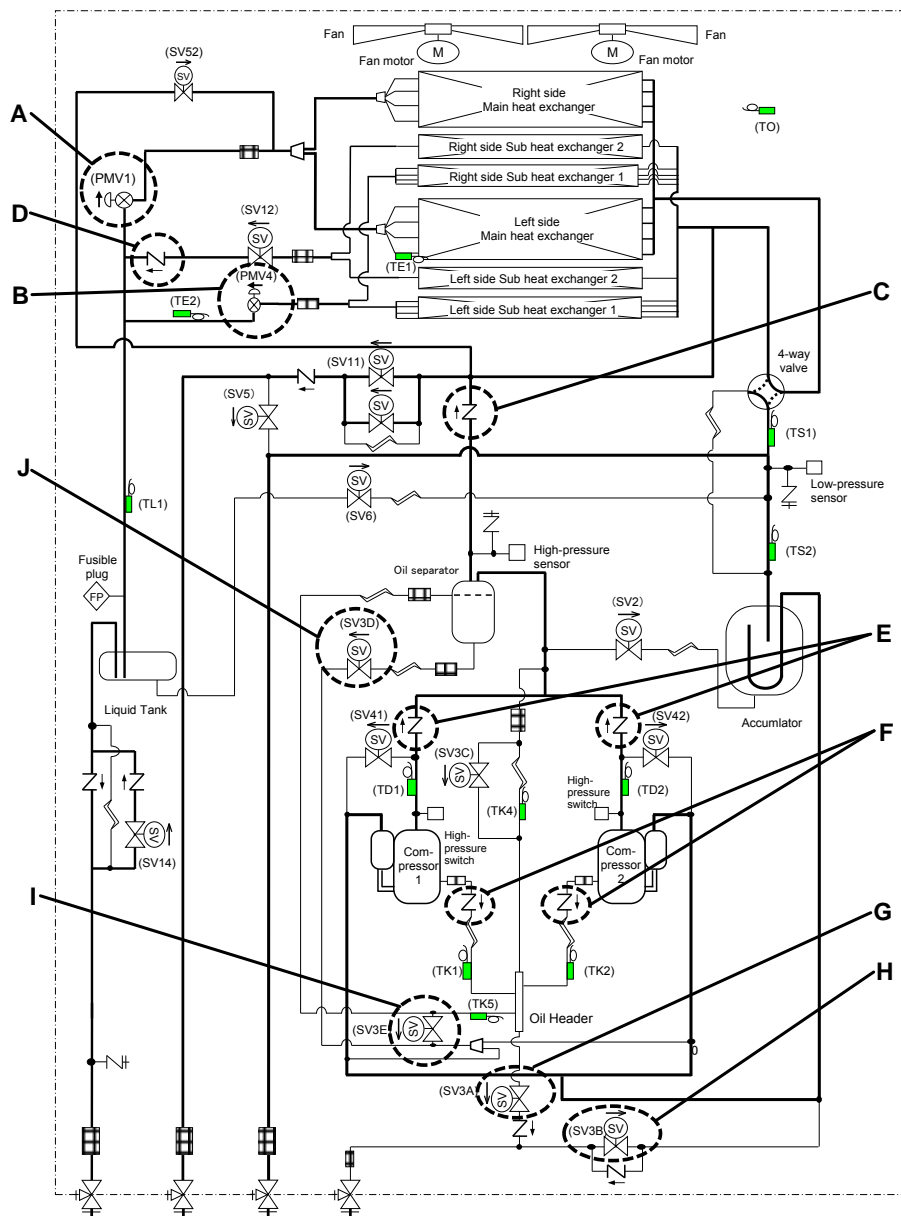

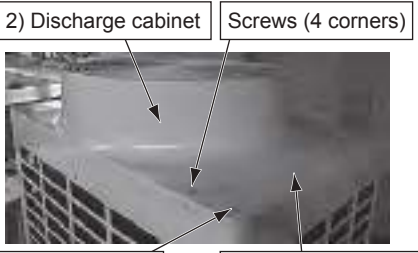
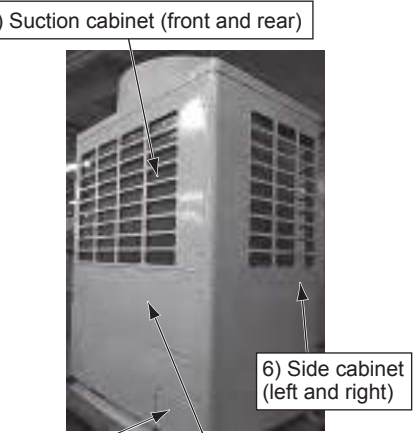
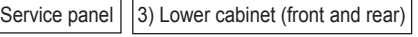
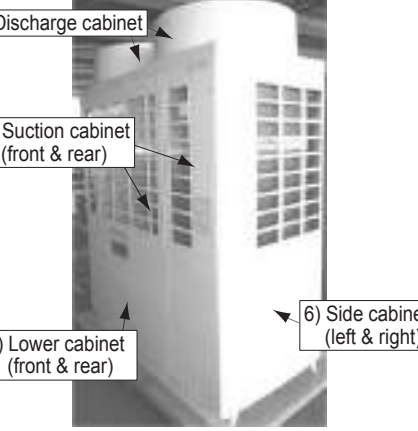

Check items and procedures to follow when checking oil circuit with compressor(s) disconnected

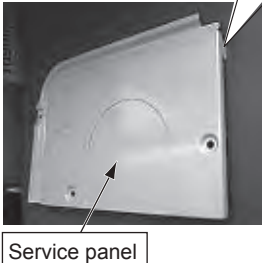
Check item	Location	Procedure
Leakage of outdoor PMV Leakage of check valve in discharge pipe convergent section	A,B C,D	1) Pressure nitrogen from check joint of the liquid pipe under condition that PMV1 and 4 are fully closed, confirm the pressure using high-pressure check joint. If pressure of the high-pressure check joint rises, leakage from any of PMV1, 4 (A, B), check valve (D) and discharge check valve (C) is considered. Therefore replace all PMV1, 4 (A, B), check valve (D), discharge check valve (C). 2) If pressure did not rise, open PMV1 fully and then confirm pressure of the high-pressure check joint. When pressure was up, open fully PMV4 only and confirm pressure of the high-pressure check joint again. 3) When pressure was up, there is leakage from check valve (D) and discharge check valve (C). Therefore replace them. If pressure did not rise, there is leakage from discharge check valve. Therefore replace them.
Leakage of check valve in discharge pipe	E	4) With pressure applied to the check joint of with nitrogen, if gas escapes from the discharge pipe section of the disconnected compressor, there is a leak from the check valve of discharge pipe (E). Replace the part.
Leakage of check valve in oil equalization circuit	F	5) With pressure applied to the check joint of with nitrogen, if gas escapes from the oil equalization pipe section of the disconnected compressor, there is a leak from the oil equalization pipe check valve (F). Replace the part.
Leakage of SV3A valve	G	6) With pressure applied to the check joint of with nitrogen, manually open the SV3B valve. If gas escapes from the suction pipe section of the disconnected compressor, there is a leak from the SV3A valve. Replace the part.
Leakage of SV3B valve	H	7) Then manually open the SV3A valve. If gas escapes from the suction pipe section of the disconnected compressor, there is a leak from the SV3B valve. Replace the part.
Clogging of SV3E valve Clogging of oil-return distributor	I	8) With pressure applied to the check joint of with nitrogen, manually open the SV3E valve. If gas does not escape from the suction pipe section of the disconnected compressor, the SV3E valve or oil-return distributor is clogged. Replace the part.
Clogging of SV3D valve Clogging of oil-return capillary Clogging of oil-return distributor	J	9) With pressure applied to the check joint of with nitrogen, manually open the SV3D valve. If gas does not escape from the suction pipe section of the disconnected compressor, the SV3D valve, oil-return capillary or oil-return distributor is clogged. Replace the part.

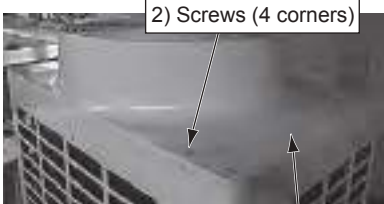

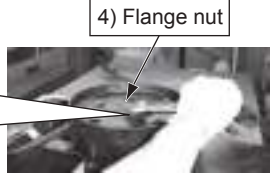

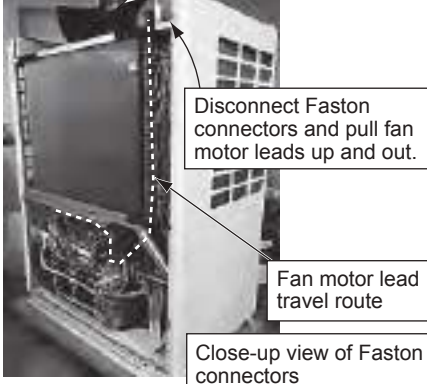
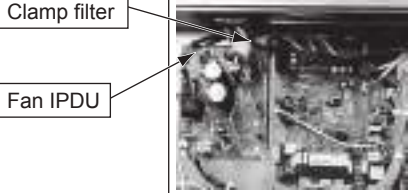

12 OUTDOOR UNIT PARTS REPLACEMENT METHODS

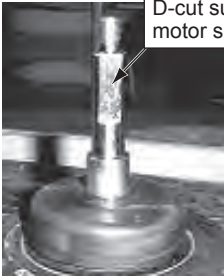
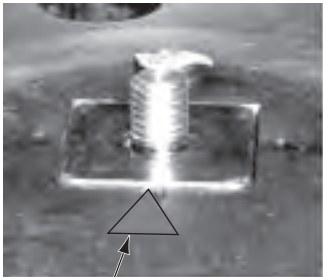
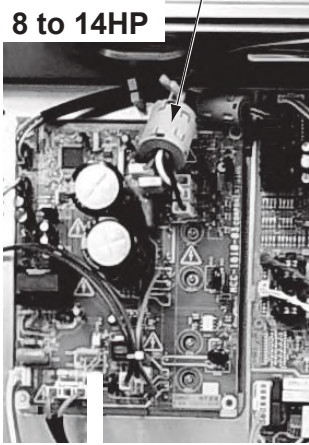
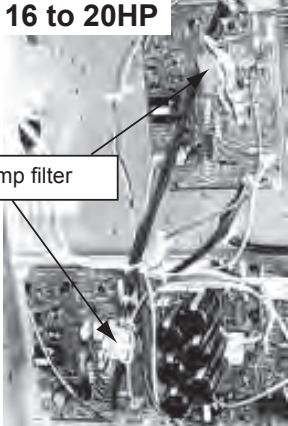

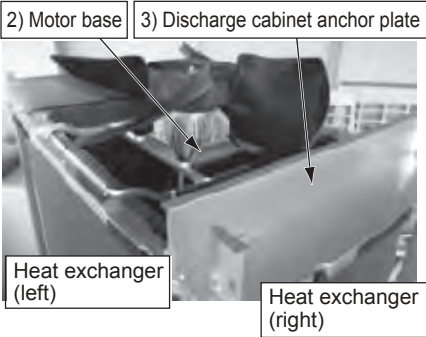
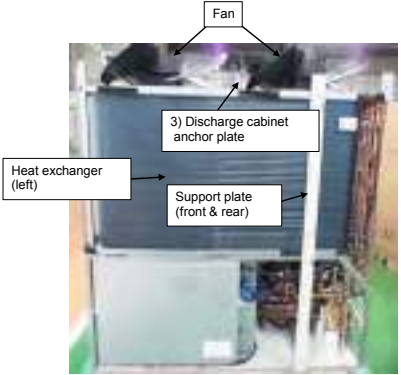
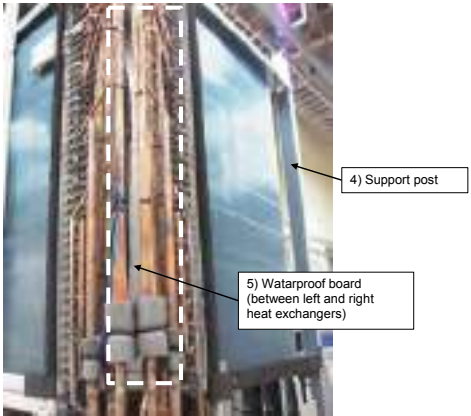
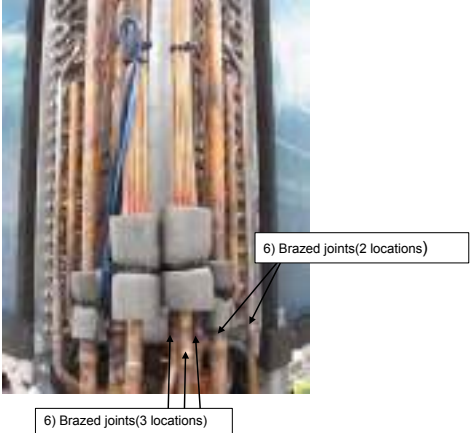
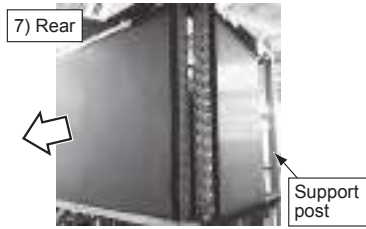

No.	Part to be replaced	Work procedure	Remarks
1	Cabinet	<p>⚠ WARNING</p> <p>Wear a pair of gloves. Otherwise, you will risk an injury involving a replacement part or some other object.</p> <p>1. Detachment</p> <p>1) Stop the air conditioner operation, and turn off the circuit breaker.</p> <p>2) Remove the screws for the discharge cabinet. (M5 × 16, 4 pcs.)</p> <div data-bbox="534 765 994 862" style="border: 1px solid black; padding: 2px;"> <p>With a 12, 14HP unit, the discharge cabinet side covers need to be removed. Left and right: (M5 × 16, 2 pcs.) - 2 sets</p> </div> <p>Remove the two discharge cabinets for 16, 18, 20HP unit.</p> <p>3) Remove the screws for the lower cabinet. Front and rear: (M5 × 10, 7 pcs. for front and 6 pcs. for rear)</p> <p>Remove the two front lower cabinets and two rear lower cabinets for 16, 18, 20HP unit. (M5 × 10, 13 pcs (Front) M5 × 10, 10 pcs (Rear))</p> <p>4) Remove the screws for the service panel. (M5 × 10, 2 pcs.)</p> <p>5) Remove the screws for the suction cabinet. Front and rear: (M5 × 10, 4 pcs. each)</p> <div data-bbox="534 1235 994 1307" style="border: 1px solid black; padding: 2px;"> <p>In the case of a 12, 14HP unit: M5 × 10, 5 pcs. each</p> </div> <p>Remove the two front discharge cabinets and two rear discharge cabinets for 16, 18, 20HP unit. (M5 × 10, 9 pcs (Front) M5 × 10, 9 pcs (Rear))</p> <p>6) Remove the screws for the discharge cabinet side cabinet. Left and right: (M5 × 10, 6 pcs. each)</p> <p>Remove the two front support plates and two rear support plates for 16, 18, 20HP unit. (M5 × 10, 6 pcs) - 2 set</p> <p>2. Attachment</p> <p>Carry out installation by following the detachment procedure in reverse (6) → 1)).</p> <p>Be careful of the hooks provided on the suction cabinet, service panel and lower cabinet.</p>	      

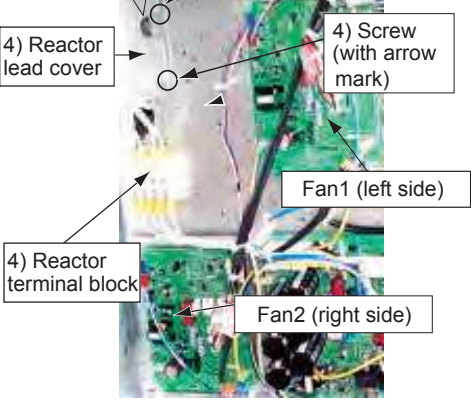
No.	Part to be replaced	Work procedure	Remarks
2	Propeller fan Fan motor	<p>⚠ WARNING</p> <p>Wear a pair of gloves. Otherwise, you will risk an injury involving a replacement part or some other object.</p> <hr/> <p>1. Detachment</p> <ol style="list-style-type: none"> 1) Stop the air conditioner operation, and turn off the circuit breaker. 2) Remove the screws for the discharge cabinet. (M5 × 10, 4 pcs.) 3) Remove the heat exchanger partition plate (upper). (M5 × 10, 2 pcs.) * With a 12, 14HP unit, the fan motor can be replaced without removing the discharge cabinet side covers. 4) Remove the flange nut securing the fan motor and propeller fan. (To loosen the nut, turn it clockwise.) 5) Remove the square washer. 6) Remove the propeller fan. <p>⚠ CAUTION</p> <p>Lift it straight up. Do not forcibly pull it, or it may get stuck.</p> <hr/> <ol style="list-style-type: none"> 7) Disconnect the Faston connectors for the fan motor leads (3 pieces) from the Fan IPDU, and pull the leads up and out. 8) Remove the fan motor. (M6 × 20, 4 pcs.) • As for 16 to 20HP outdoor unit, the number of Fan, Fan motor, Motor base, Flange nut, Washer and Fan P.C Board are twice compare to 8 to 14HP outdoor unit because 2 Fans are equipped. 	 <p>2) Screws (4 corners)</p> <p>Discharge cabinet side cover</p>  <p>3) Heat exchanger partition plate (upper)</p>  <p>4) Flange nut</p>  <p>5) Square washer</p>  <p>6)</p>  <p>8) Screw (4 locations)</p>  <p>7)</p> <p>Disconnect Faston connectors and pull fan motor leads up and out.</p> <p>Fan motor lead travel route</p> <p>Close-up view of Faston connectors</p>  <p>Clamp filter</p> <p>Fan IPDU</p>

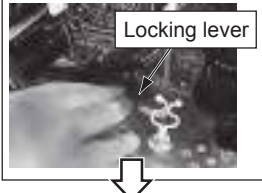
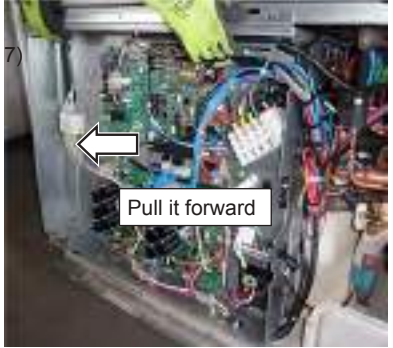
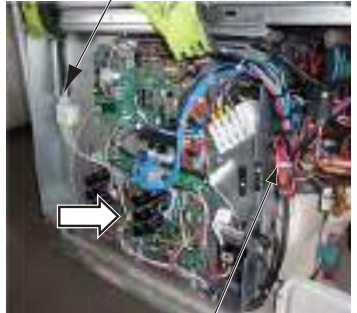

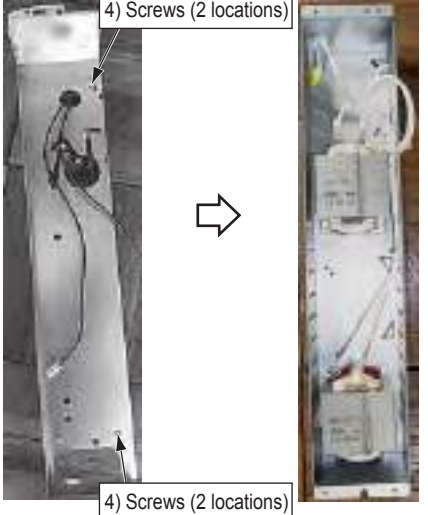

No.	Part to be replaced	Work procedure	Remarks
2	Propeller fan Fan motor (continued)	<p>2. CAUTION for replacement or attachment</p> <p>1) Insert the propeller fan while aligning the D-cut surface of the fan motor shaft with the arrow mark (△) on the fan. (If the propeller fan is tightly mounted on the shaft without securing alignment between the D-cut surface and the arrow mark (△), it may cause the fan to melt and fall off due to friction heat.)</p> <p>2) Be sure to put the square washer in place. (Otherwise, unusual noises and vibrations may result.)</p> <p>3) Tighten the flange nut at a torque of 15N•m (153kgf•cm). (To tighten the flange nut, turn it counterclockwise.)</p> <p>4) Remove the clamp filter from the fan motor with trouble, then attach the clamp filter to the substitution in the same way as before replacement. (Turn through the fan motor lead once around the clamp filter.)</p> <ul style="list-style-type: none"> Apply the same procedure again for 16 to 20HP unit to replace another clamp filter. 	 <p>D-cut surface of fan motor shaft</p>  <p>Arrow mark (△) of fan To be aligned with D-cut surface</p> <p>4) Clamp filter</p> <p>8 to 14HP</p>  <p>16 to 20HP</p>  <p>4) Clamp filter</p>

No.	Part to be replaced	Work procedure	Remarks
3	Heat exchanger	<p>⚠ WARNING</p> <p>Wear a pair of gloves. Otherwise, you will risk an injury involving a replacement part or some other object.</p> <hr/> <p>Before the work, be sure to recover the refrigerant of outdoor unit into cylinders or another unit connected to the same system. (Refer to the chapter on "refrigerant recovery methods to be used during compressor replacement".)</p> <p>1. Detachment (Right-Side Heat Exchanger as Example)</p> <p>1) Remove the cabinet. 2) Remove the motor base. (M5 × 10, 6 pcs.) Remove the two motor bases for 16 to 20HP unit. (M5 × 10, 6 pcs) - 2 set (Detach the fan motor leads as well.)</p> <div style="border: 1px solid black; padding: 5px; margin: 5px 0;"> <p>With a 12, 14HP unit, remove the discharge cabinet anchor plates. Left and right: (M5 × 10, 2 pcs.) - 2 sets</p> </div> <p>With 16 to 20HP unit, remove the discharge cabinet anchor plate. (M5 × 10, 2 pcs)</p> <p>3) Remove the upper partition plate. (M5 × 10, 5 pcs.)</p> <p>4) Remove the screws for the support post. (M5 × 10, 2 pcs.)</p> <p>5) Remove the screws for the waterproof board. (M4 × 10, 2 pcs.)</p> <p>6) Remove the brazed joints of the piping connected (8 to 14HP : 4 locations, 16 to 20HP : 5 locations).</p> <p>7) Remove the screws for the heat exchanger end plate and pull the heat exchanger out. (M5 × 10, 2 pcs.)</p>	 <p>2) Motor base 3) Discharge cabinet anchor plate</p> <p>Heat exchanger (left) Heat exchanger (right)</p>  <p>Fan</p> <p>3) Discharge cabinet anchor plate</p> <p>Heat exchanger (left)</p> <p>Support plate (front & rear)</p>  <p>4) Support post</p> <p>5) Waterproof board (between left and right heat exchangers)</p>  <p>6) Brazed joints(2 locations)</p> <p>6) Brazed joints(3 locations)</p>  <p>7) Rear</p> <p>Support post</p> <p>Pull heat exchanger out of rear end. (Left-side heat exchanger is pulled out of front end.)</p>

No.	Part to be replaced	Work procedure	Remarks
4	Inverter assembly	<p>⚠ WARNING</p> <p>Wear a pair of gloves. Otherwise, you will risk an injury involving a replacement part or some other object.</p> <p>1. Detachment</p> <p>1) Stop the air conditioner operation, and turn off the circuit breaker.</p> <p>2) Remove the inverter cover. (M4 × 10, 2 pcs.)</p> <p>3) Remove the wiring. (e.g. the power supply wire, compressor leads, coils, sensors and heaters)</p> <p>4) Steps only applicable to a 12 to 20HP unit</p> <ul style="list-style-type: none"> • Remove the reactor lead cover. (M4 × 10, 1 pc.) • Remove the screws securing the box. (M4 × 10, 1 pc.) • Detach the reactor leads. (4 terminal block bolts) <p>5) Remove the screws securing the box. (M5 × 10, 1 pc. each for top and bottom)</p> <p>In the case of a 12 to 20HP unit: M5 × 10, 3 pcs. for top and 2 pcs for bottom</p> <p>6) Disengage the hook by gently pressing down the locking lever with your finger. (The lower part of the box moves forward.)</p> <p>7) Hold the top board with both hands to disengage the top hook.</p> <p>2. Attachment</p> <p>Carry out installation by following the dismantling procedure in reverse (7 → 1)).</p> <p>Before pushing the lower part in, pull the reactor leads out. Take care so that the wiring does not get caught in the way.</p> <p>Reconnect all the wiring.</p>	<p>Remarks</p>  <p>4) Screw (with arrow mark)</p> <p>Removable design</p>  <p>4) Reactor lead cover</p> <p>4) Reactor terminal block</p> <p>4) Screw (with arrow mark)</p> <p>Fan1 (left side)</p> <p>Fan2 (right side)</p>  <p>5) Screw</p>  <p>5) Screws with arrow mark (2 locations)</p> <p>Locking lever</p>  <p>7)</p> <p>Pull it forward</p> <p>Before pushing lower part in, pull leads out through hole.</p>  <p>When pushing lower part in, be sure to keep wiring out of way.</p>

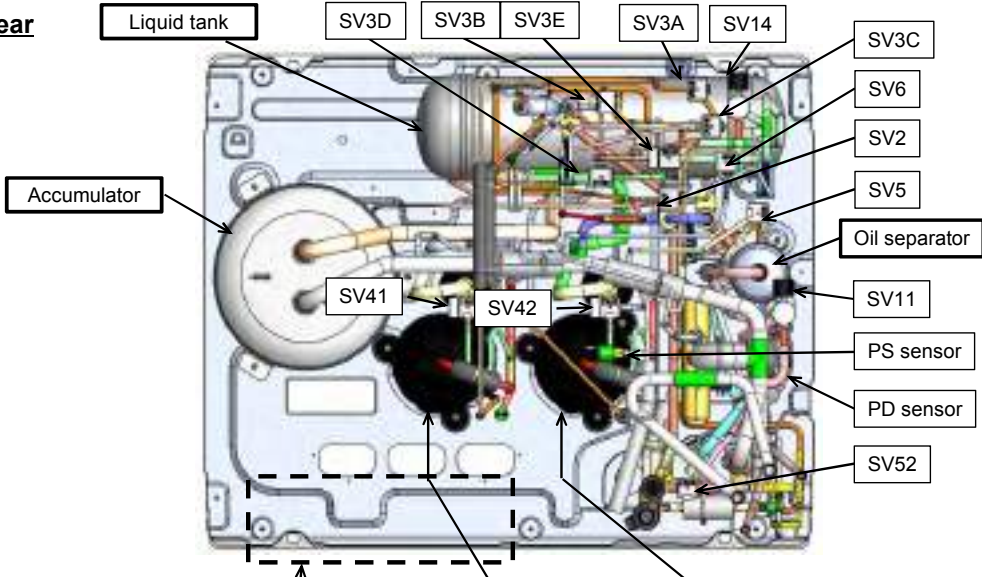
No.	Part to be replaced	Work procedure	Remarks
5	Reactor assembly	<p>⚠ WARNING</p> <p>Wear a pair of gloves. Otherwise, you will risk an injury involving a replacement part or some other object.</p> <hr/> <p>1. Detachment</p> <p>1) Stop the operation, and turn off the circuit breaker.</p> <p>2) Remove the inverter assembly. (See the inverter assembly dismantling method under item 4.)</p> <div data-bbox="513 669 1015 874" style="border: 1px solid black; padding: 5px;"> <p>3) With a 12 to 20HP unit, remove the separately mounted reactor box. To remove the reactor box, remove the screws at the top and bottom (M5 × 10) and unlock the box by sliding the stopper to the right. * Before pulling the reactor box, tilt it back to free the bottom.</p> </div> <p>4) Remove the reactor box located at the back of the inverter assembly. (M4 × 6, 4 pcs.) * The screws can be removed from the front.</p> <div data-bbox="531 1023 994 1114" style="border: 1px solid black; padding: 5px;"> <p>With a 12 to 20HP unit, remove the separately mounted anchor plate. (M4 × 6, 4 pcs.)</p> </div> <p>5) Remove and replace the reactor. (M4 × 6, 1 pc.)</p>	<p>• 12 to 20HP case</p> <div data-bbox="1072 349 1498 512"> <p>3) Screw Fixing claw (slide stopper to right)</p>  </div> <div data-bbox="1072 609 1498 837"> <p>3) Screw</p>  <p>Fixing claw (slide stopper to right)</p> </div> <div data-bbox="1072 862 1498 1379"> <p>4) Screws (2 locations)</p>  <p>4) Screws (2 locations)</p> </div> <p>• 8, 10HP case</p> <div data-bbox="1112 1464 1459 2017"> <p>4) Screws (2 locations)</p>  <p>4) Screws (2 locations)</p> </div>

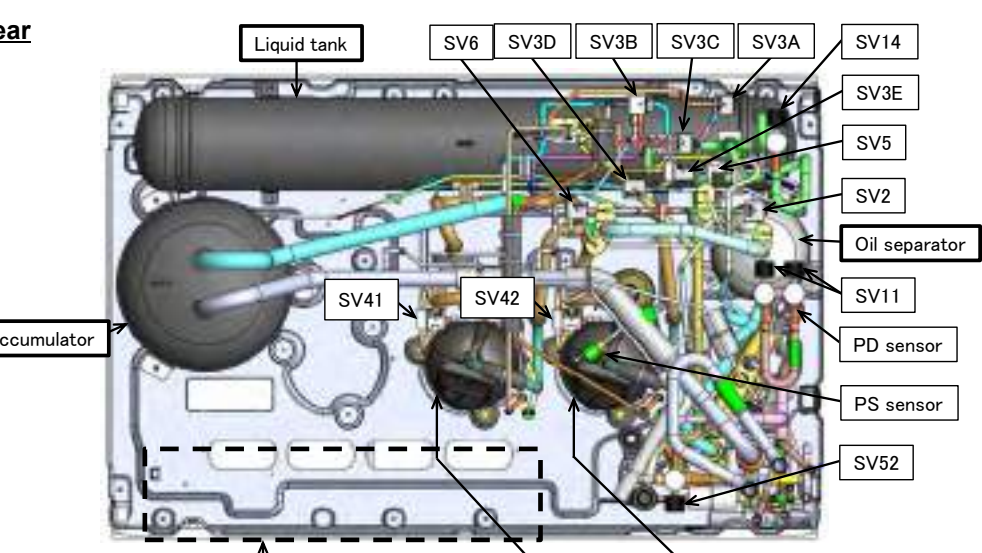
(For FT8(J)P-E, FT8(J)P-TR, FT8(J)P-UK model)

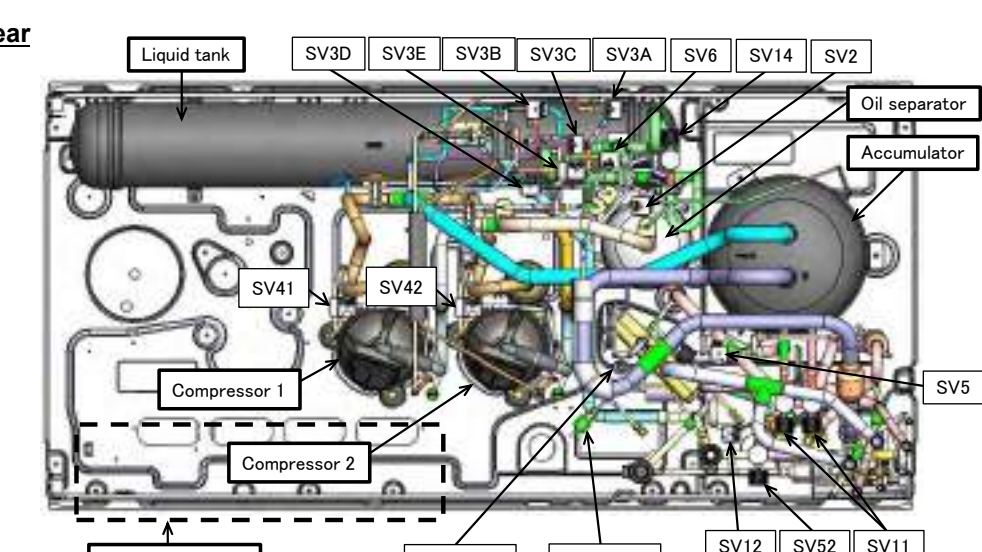
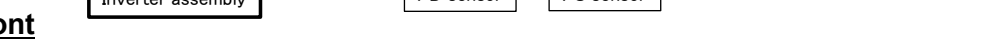
No.	Part to be replaced	Work procedure	Remarks
6	2-way valve coils Pressure sensors locations MAP0806* MAP1006*	<p>Rear</p>  <p>Front</p> 	
MAP1206* MAP1406*		<p>Rear</p>  <p>Front</p> 	
MAP1606* MAP1806* MAP2006*		<p>Rear</p>  <p>Front</p> 	

(For FT8(J)P, FT7(J)P, FT8P-A model)

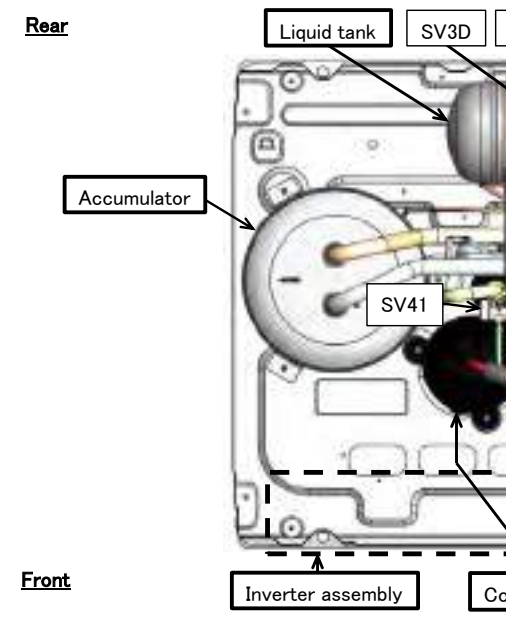
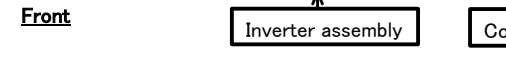
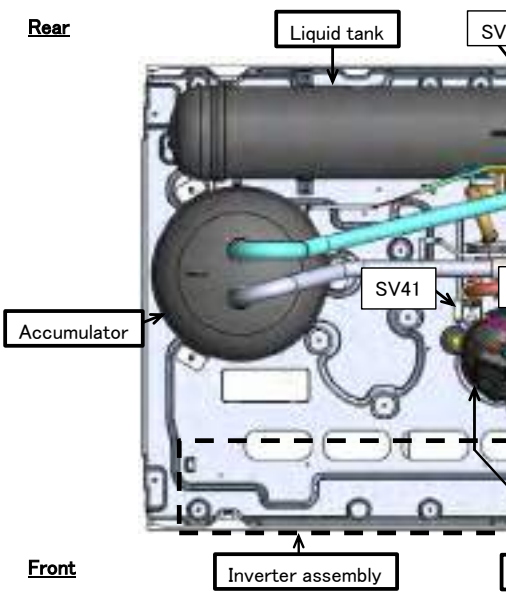
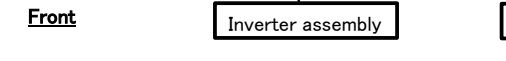
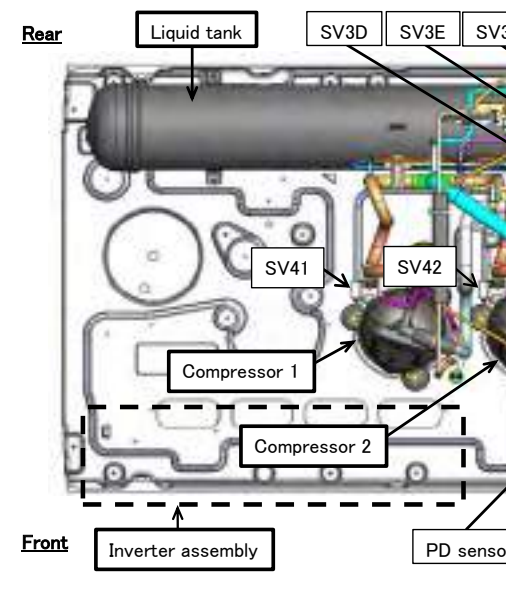
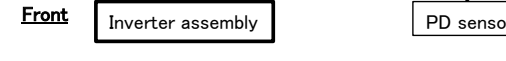

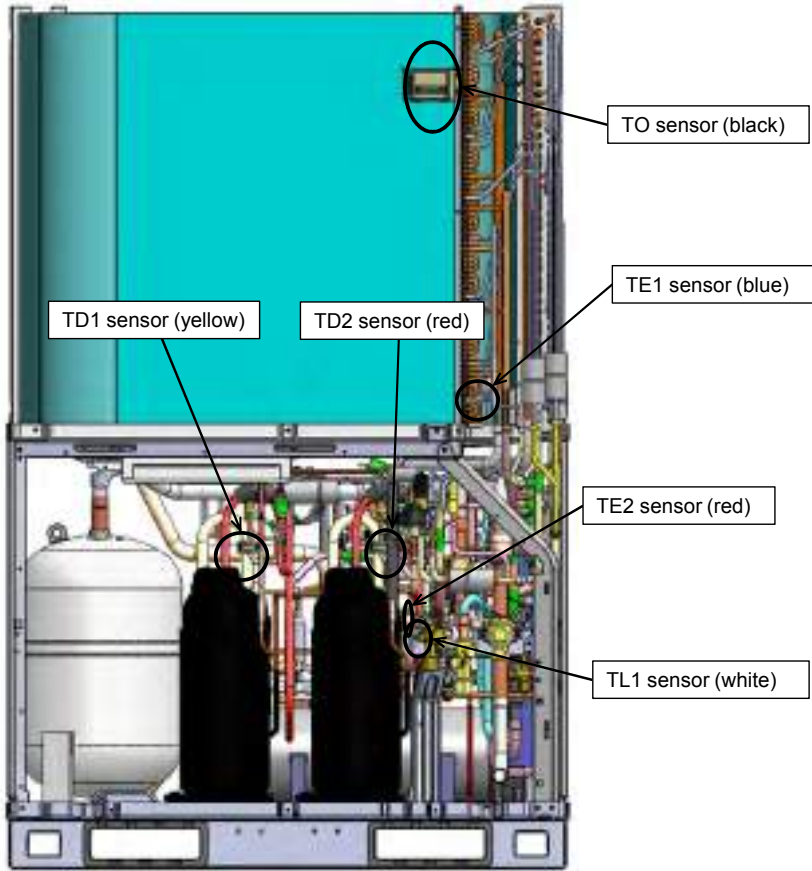
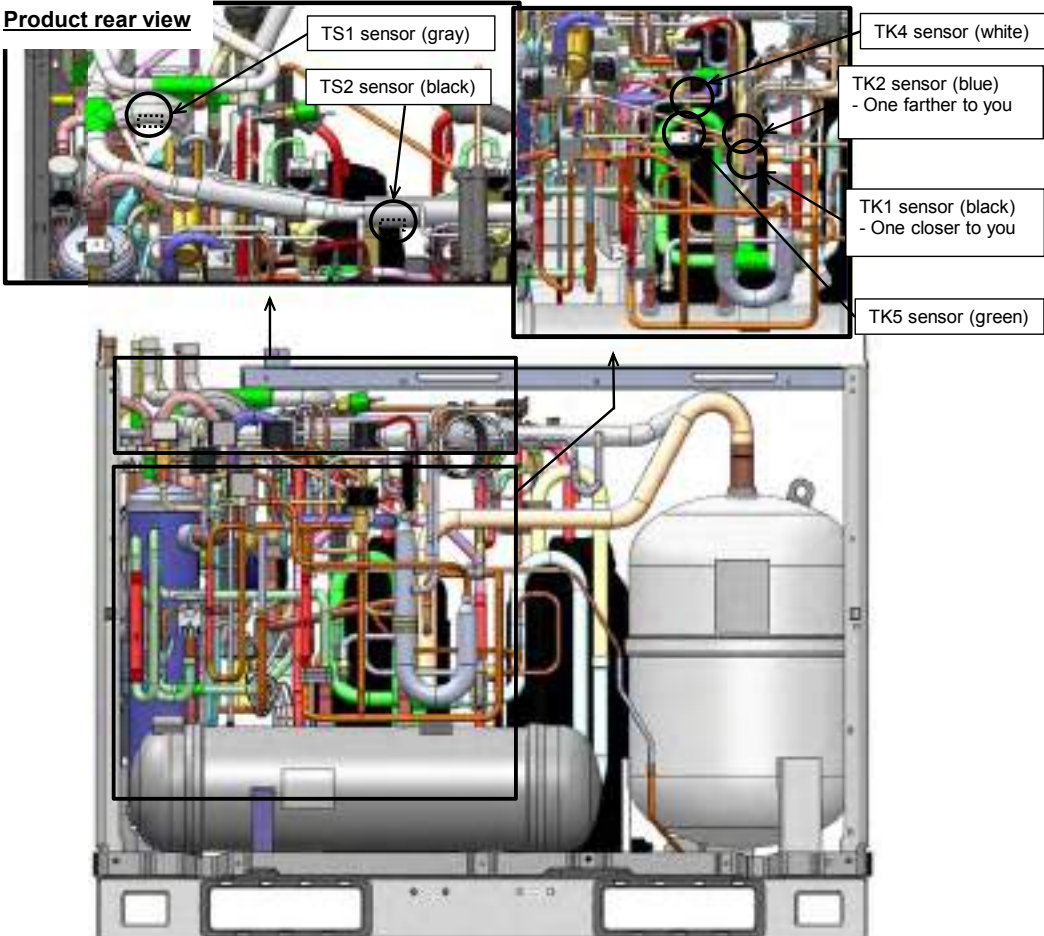
No.	Part to be replaced	Work procedure	Remarks
6	2-way valve coils Pressure sensors locations MAP0806* MAP1006*	<p>Rear</p>  <p>Front</p> 	
MAP1206* MAP1406*		<p>Rear</p>  <p>Front</p> 	
MAP1606* MAP1806* MAP2006*		<p>Rear</p>  <p>Front</p> 	

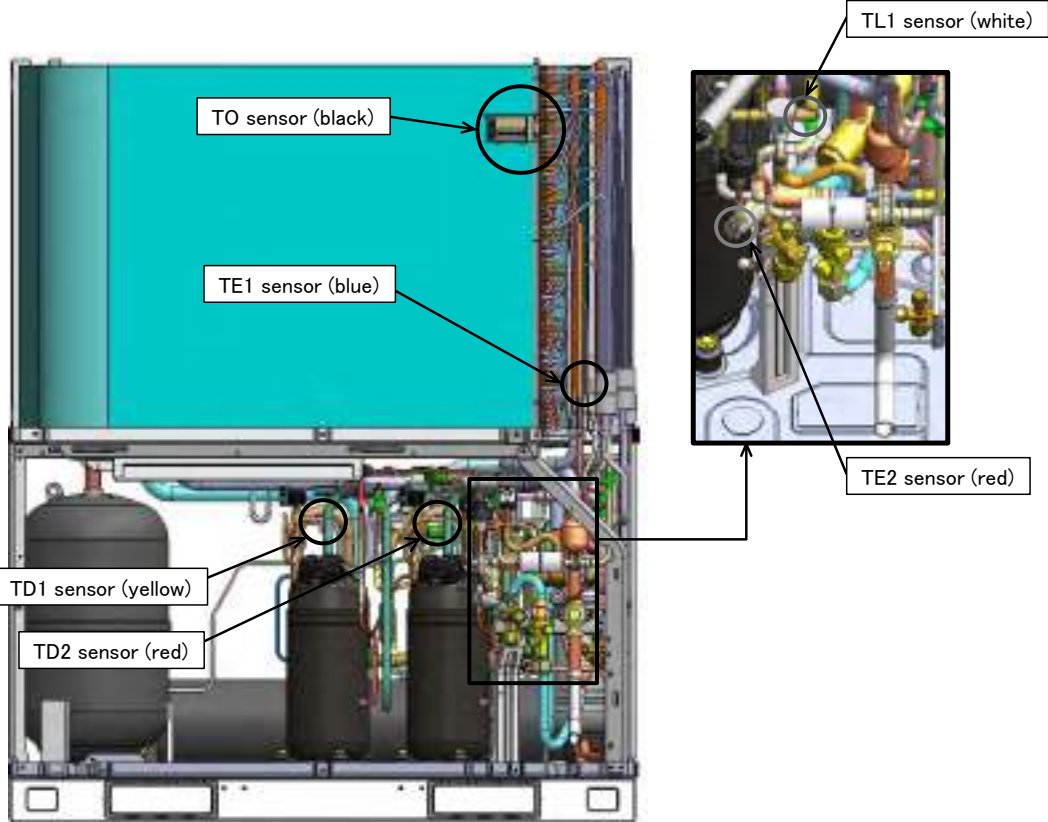
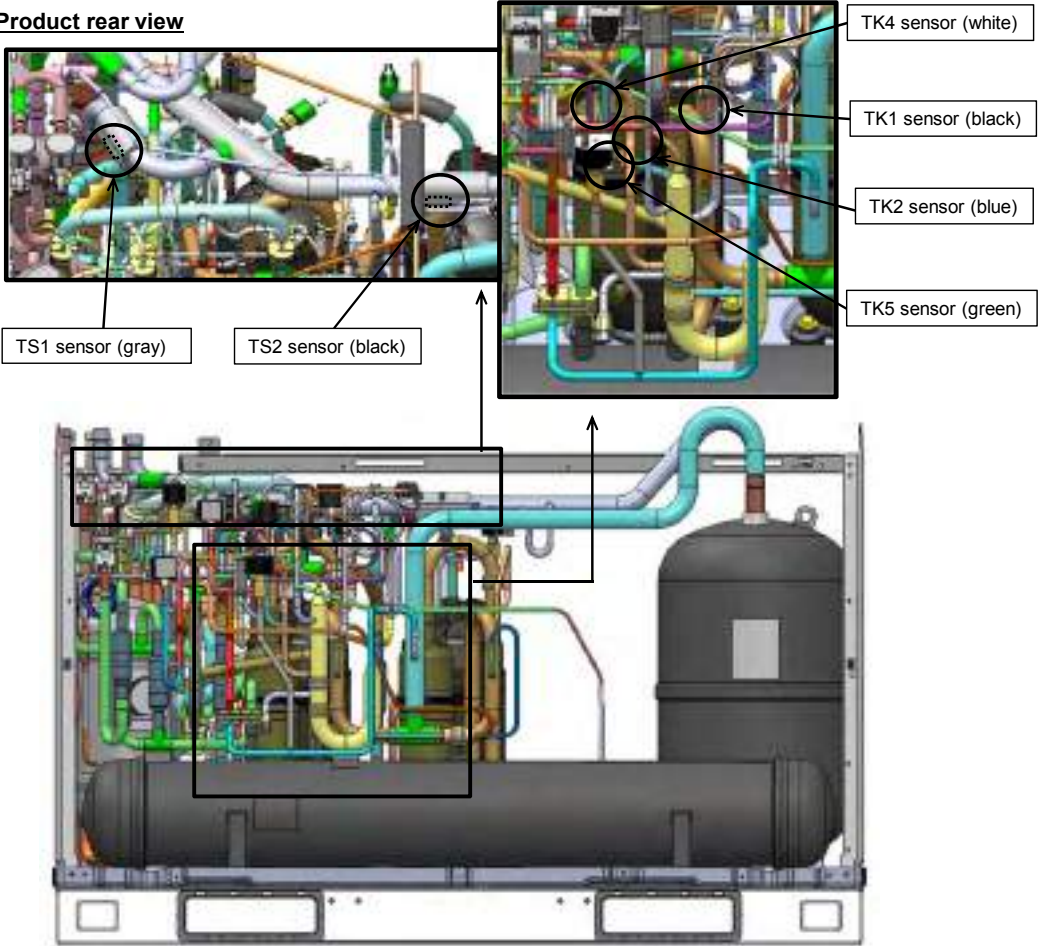
No.	Part to be replaced	Work procedure	Remarks
7	Temperature sensors - locations and identification colors MAP0806* MAP1006*	<p>Product front view</p>  <p>Product rear view</p> 	

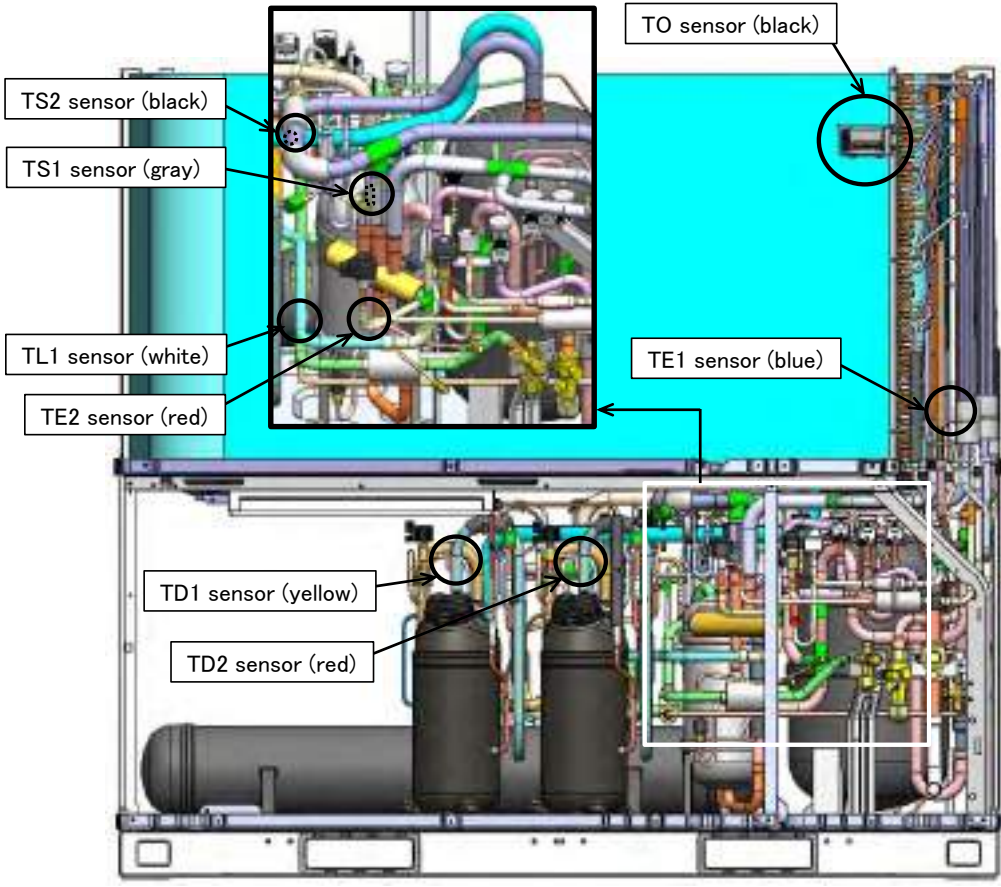
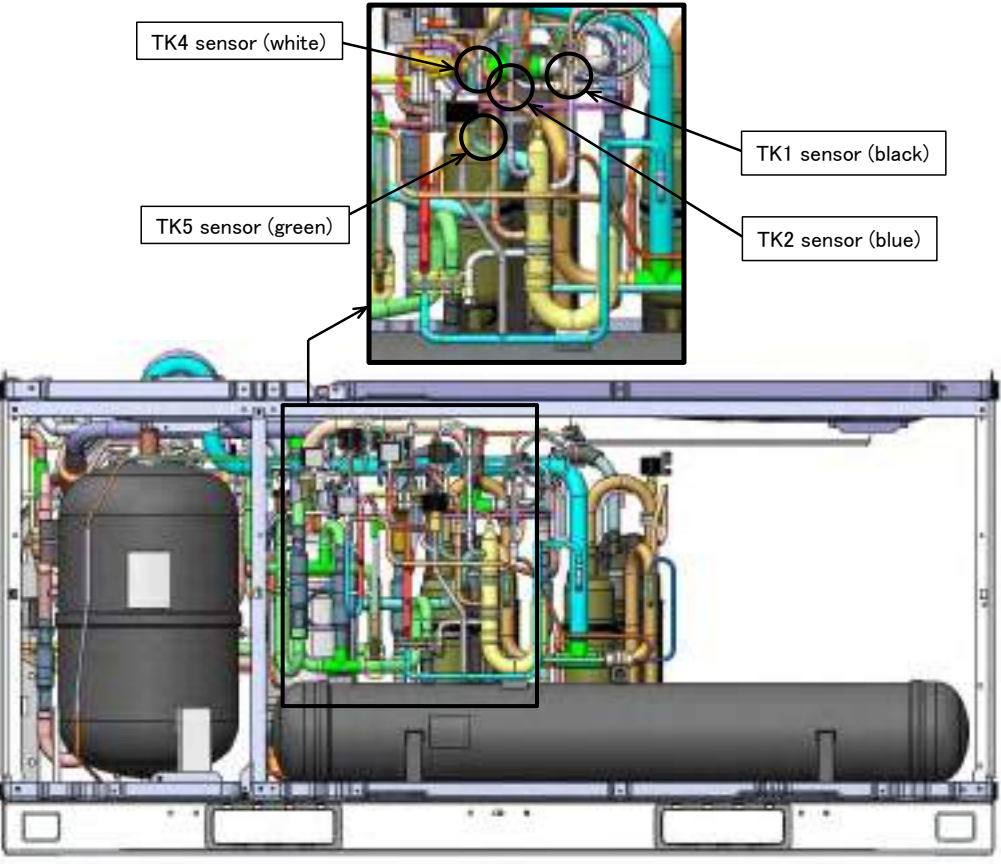
No.	Part to be replaced	Work procedure	Remarks
7	Temperature sensors - locations and identification colors MAP1206* MAP1406*	<p>Product front view</p>  <p>TO sensor (black)</p> <p>TE1 sensor (blue)</p> <p>TD1 sensor (yellow)</p> <p>TD2 sensor (red)</p> <p>TL1 sensor (white)</p> <p>TE2 sensor (red)</p>	<p>Product rear view</p>  <p>TS1 sensor (gray)</p> <p>TS2 sensor (black)</p> <p>TK4 sensor (white)</p> <p>TK1 sensor (black)</p> <p>TK2 sensor (blue)</p> <p>TK5 sensor (green)</p>

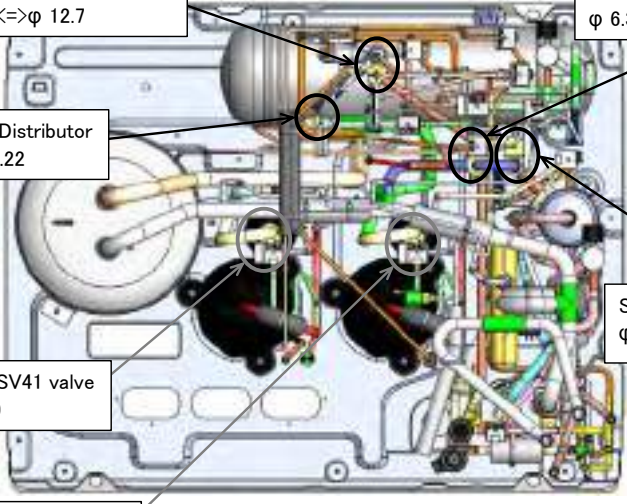
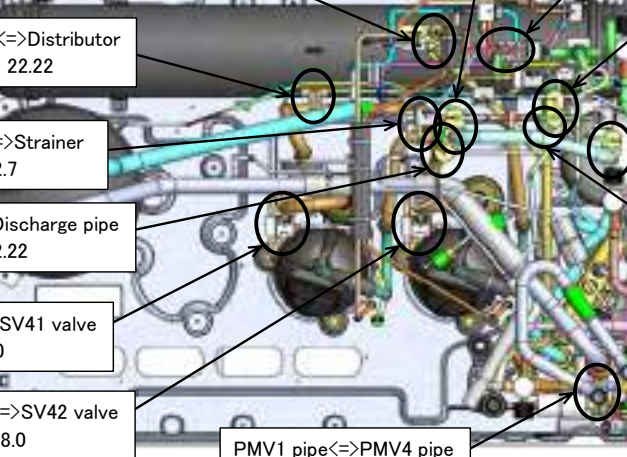
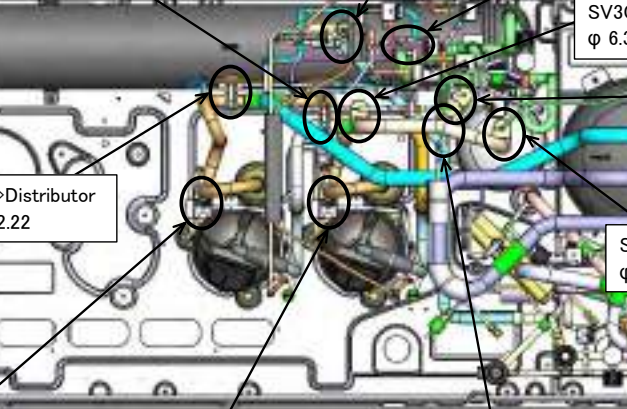
No.	Part to be replaced	Work procedure	Remarks
7	Temperature sensors - locations and identification colors MAP1606* MAP1806* MAP2006*	<p>Product front view</p>  <p>TS2 sensor (black)</p> <p>TS1 sensor (gray)</p> <p>TL1 sensor (white)</p> <p>TE2 sensor (red)</p> <p>TD1 sensor (yellow)</p> <p>TD2 sensor (red)</p> <p>TO sensor (black)</p> <p>TE1 sensor (blue)</p>	<p>Product rear view</p>  <p>TK4 sensor (white)</p> <p>TK5 sensor (green)</p> <p>TK1 sensor (black)</p> <p>TK2 sensor (blue)</p>

No.	Part to be replaced	Work procedure	Remarks
8	Pipe fixing rubber - detachment/ attachment MAP0806* MAP1006*	 <p>Oil header=>Liquid pipe φ 25.4=>φ 12.7</p> <p>Suction pipe=>Distributor φ 19.05=>φ 22.22</p> <p>Suction pipe=>SV41 valve φ 19.05=>φ 8.0</p> <p>Suction pipe=>SV42 valve φ 19.05=>φ 8.0</p> <p>SV2 valve=>Discharge pipe φ 6.35=>φ 15.88</p> <p>SV6 valve=>Discharge pipe φ 6.35=>φ 19.05</p>	
MAP1206* MAP1406*		 <p>Oil header=>Liquid pipe φ 25.4=>φ 15.88 2set</p> <p>Suction pipe=>Distributor φ 22.22=>φ 22.22</p> <p>Discharge pipe=>Strainer φ 19.05=>φ 12.7</p> <p>SV6 valve=>Discharge pipe φ 6.35=>φ 22.22</p> <p>Suction pipe=>SV41 valve φ 22.22=>φ 8.0</p> <p>Suction pipe=>SV42 valve φ 22.22=>φ 8.0</p> <p>SV3C valve=>Discharge pipe φ 6.35=>φ 22.22</p> <p>SV3AB valve=>Liquid pipe φ 9.52=>φ 15.88</p> <p>SV2 valve=>SV5 valve φ 6.35=>φ 8.0</p> <p>SV2 valve=>Discharge pipe φ 6.35=>φ 22.22</p> <p>Liquid pipe=>Balance pipe φ 15.88=>φ 9.52</p> <p>PMV1 pipe=>PMV4 pipe φ 15.88=>φ 12.7</p>	
MAP1606* MAP1806* MAP2006*		 <p>Discharge pipe=>Strainer φ 22.22=>φ 12.7</p> <p>Oil header=>Liquid pipe φ 25.4=>φ 19.05 3set</p> <p>Suction pipe=>Distributor φ 22.22=>φ 22.22</p> <p>Suction pipe=>SV41 valve φ 22.22=>φ 8.0</p> <p>Suction pipe=>SV42 valve φ 22.22=>φ 8.0</p> <p>Liquid pipe=>Balance pipe φ 19.05=>φ 9.52</p> <p>SV3A valve=>Liquid pipe φ 9.52=>φ 19.05</p> <p>SV3C valve=>Discharge pipe φ 6.35=>φ 25.4</p> <p>SV2 valve=>SV6 valve φ 6.35=>φ 6.35</p> <p>SV2 valve=>Discharge pipe φ 6.35=>φ 25.4</p> <p>PMV1 pipe=>PMV4 pipe φ 15.88=>φ 12.7</p>	

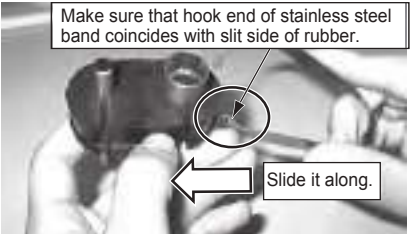
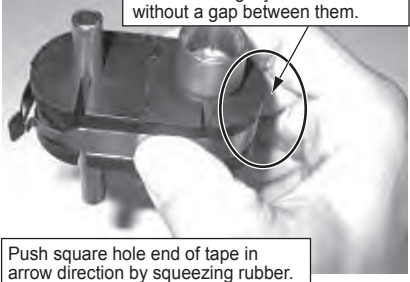
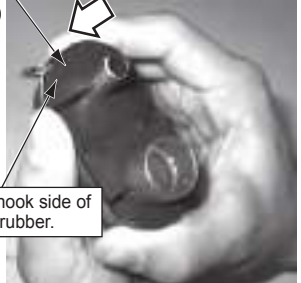
No.	Part to be replaced	Work procedure	Remarks
8	Pipe fixing rubber - detachment/ attachment (common)	<p>⚠ WARNING</p> <p>Wear a pair of gloves. Otherwise, you will risk an injury involving a replacement part or some other object.</p> <p>1. Detachment</p> <p>1) Hold the pipe fixing rubber in such a manner that your fingers and thumb are in contact with the two longitudinal ends of the piece, and squeeze it a little to create a small gap between the rubber and the stainless steel band wrapped around it.</p> <p>2) Push the hook end of the stainless steel band down to disengage the hook from the square hole.</p> <p>2. Attachment</p> <p>1) The pipe fixing rubbers use a two-segment design to accommodate a wide range of pipe combinations. When installing them, therefore, it is recommended to first split them up into segments and pair the segments up only after placing them on pipes of matching sizes separately. In this regard, make sure that the mating tooth and slit of pairing segments face each other.</p> <p>2) When placing a stainless steel band around pipe fixing rubber, make sure that the hook end of the stainless steel band coincides with the slit side of the rubber. (The band can be placed the other way around, but only at the expense of work efficiency.)</p> <p>3) Place the stainless steel band tightly around the pipe fixing rubber so that there is no gap between them. Take utmost care not to create a gap over the curved section of the rubber where the hairpin side of the band is located.</p> <p>4) While holding the rubber, press down the base of the hook lightly against the rubber, and engage the hook with the square hole by squeezing the curved section of the rubber where the square hole side of the band is located (see the arrow). (If the hook does not engage with the square hole, recheck whether there is a gap between the band and rubber.)</p>	<p>1)  Squeeze rubber to create small gap.</p> <p>2)  Push band down in arrow direction.</p> <p>Place two segments of damper on pipes of matching sizes separately, making sure tooth and slit of pairing segments face each other.</p> <p>1)  Align tooth and slit and push two segments towards each other.</p> <p>2)  Make sure that hook end of stainless steel band coincides with slit side of rubber. Slide it along.</p> <p>Place band tightly around rubber without a gap between them.</p> <p>3)  Push square hole end of tape in arrow direction by squeezing rubber.</p> <p>4)  Press down hook side of tape against rubber.</p>

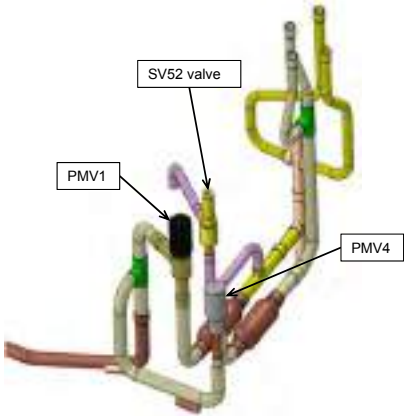
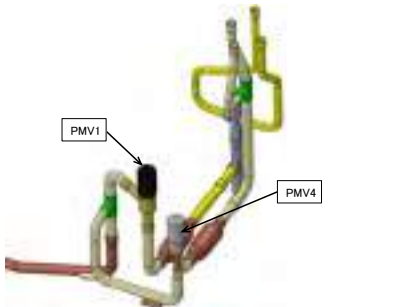
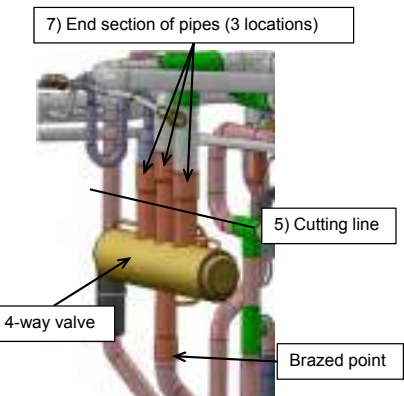
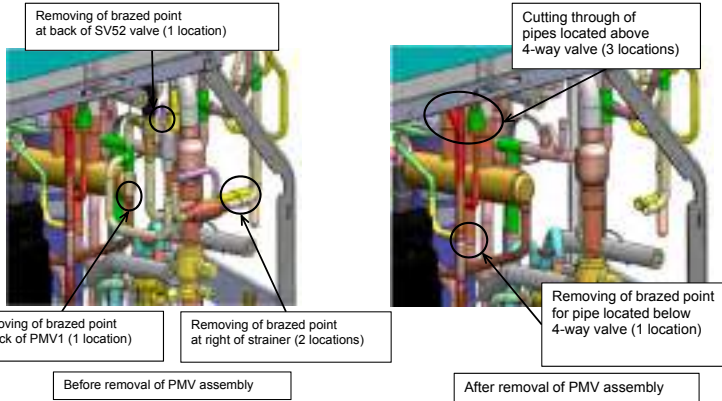
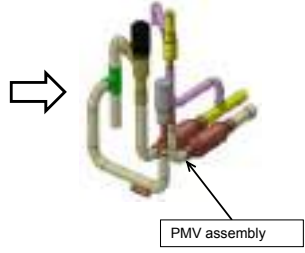
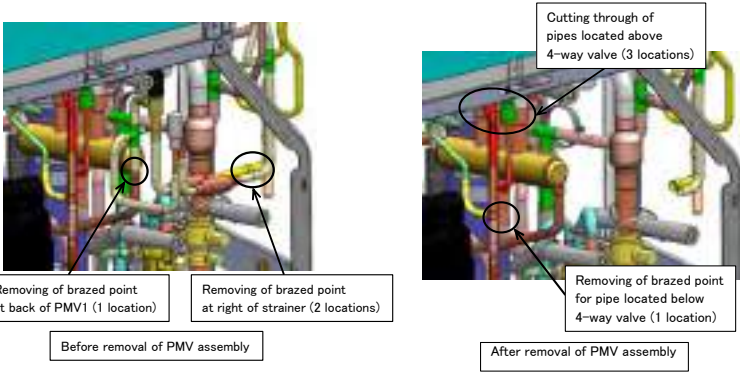
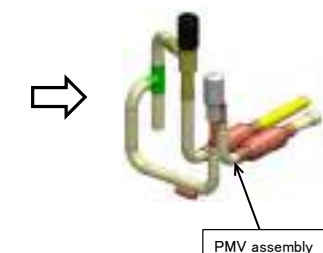
No.	Part to be replaced	Work procedure	Remarks
9	4-way valve - detachment/ attachment MAP0806* MAP1006*	<p>⚠ WARNING</p> <p>Wear a pair of gloves. Otherwise, you will risk an injury involving a replacement part or some other object.</p> <hr/> <p>Before starting the work, be sure to recover the refrigerant of outdoor unit by removing it with a refrigerant recovery device.</p> <p>1. Detachment</p> <ol style="list-style-type: none"> 1) Remove the lower cabinet (front side). 2) Remove the inverter box in accordance with the dismantling instructions. 3) Disconnect the 4-way valve coil, SV52 valve coil (*1), PMV1 coil and PMV4 coil and get all wiring located near the 4-way valve out of the way. (*1 Only FT8(J)P-E, FT8(J)P-TR, FT8(J)P-UK model) 4) Remove brazed points for the PMV assembly, which is placed in front of the 4-way valve. * Provide adequate cover for the PMV to protect it from overheating. 5) Since it is difficult to simultaneously remove the brazed points for the pipes located above the 4-way valve (3 locations), cut through them just below the brazed points using a saw, etc. 6) Detach the pipe located below the 4-way valve. 7) Remove the end sections of the pipes above the 4-way valve, which were cut in step 5). 8) Install a new 4-way valve. * Provide adequate cover for the 4-way valve to protect it from overheating. During the installation, insert pipes firmly into the 4-way valve, or a blockage or leakage involving brazing filler metal may result. 9) Reinstall the PMV assembly, which was removed in step 4). * Provide adequate cover for the PMV to protect it from overheating. 10) Reinstall all the coils removed in step 3), and put the wiring back to its initial state. 11) Reinstall the inverter box in accordance with the installation instructions. 12) Reinstall the lower cabinet. 	<p>For FT8(J)P-E, FT8(J)P-TR, FT8(J)P-UK model</p>  <p>For FT8(J)P, FT7(J)P, FT8P-A model</p>  
		<p>For FT8(J)P-E, FT8(J)P-TR, FT8(J)P-UK model</p> 	
		<p>For FT8(J)P, FT7(J)P, FT8P-A model</p> 	

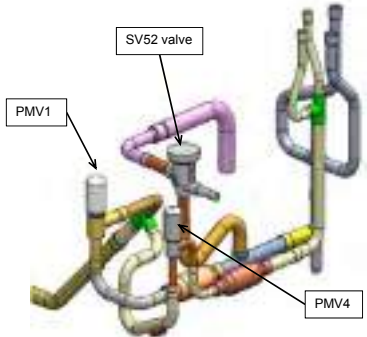
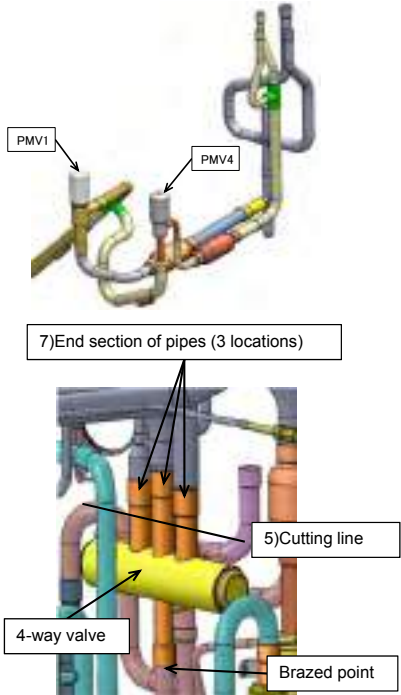
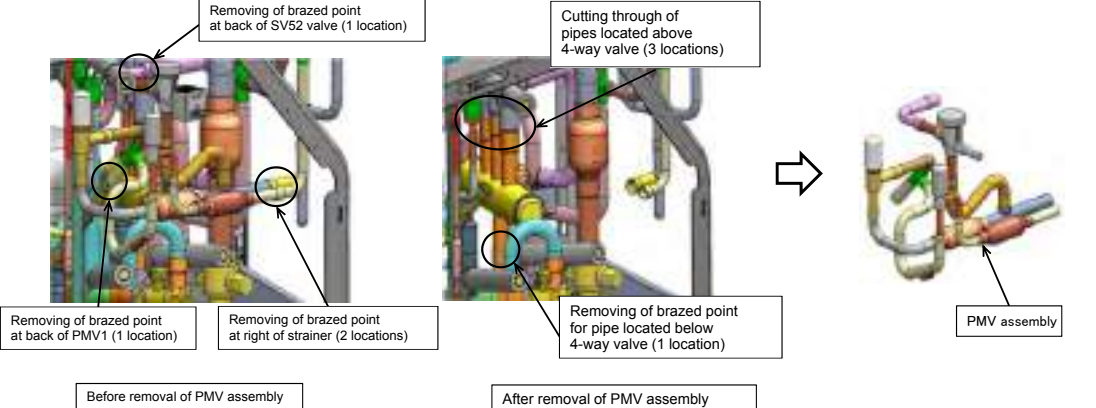
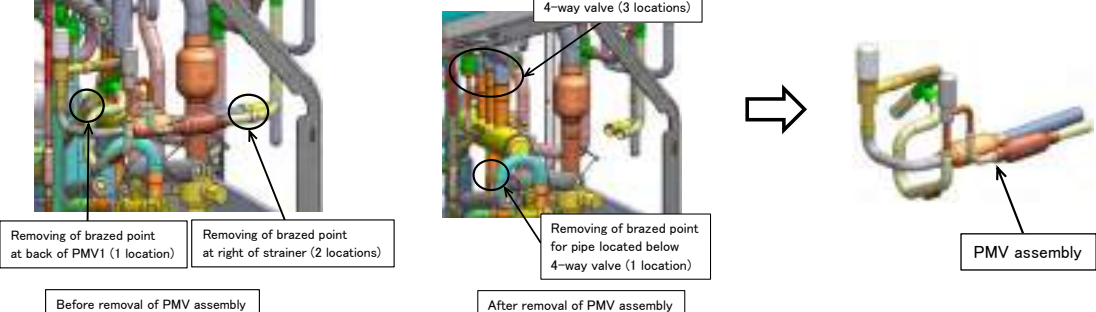
No.	Part to be replaced	Work procedure	Remarks
9	4-way valve - detachment/ attachment (continued) MAP1206* MAP1406*	<p>⚠ WARNING</p> <p>Wear a pair of gloves. Otherwise, you will risk an injury involving a replacement part or some other object.</p> <p>Before starting the work, be sure to recover the refrigerant of outdoor unit by removing it with a refrigerant recovery device.</p> <p>1. Detachment</p> <ol style="list-style-type: none"> Remove the lower cabinet (front side). Remove the inverter box in accordance with the dismantling instructions. Disconnect the 4-way valve coil, SV52 valve coil (*1), PMV1 coil and PMV4 coil and get all wiring located near the 4-way valve out of the way. (*1 Only FT8(J)P-E, FT8(J)P-TR, FT8(J)P-UK model) Remove brazed points for the PMV assembly, which is placed in front of the 4-way valve. <ul style="list-style-type: none"> * Provide adequate cover for the PMV proper to protect it from overheating. Since it is difficult to simultaneously remove the brazed points for the pipes located above the 4-way valve (3 locations), cut through them just below the brazed points using a saw, etc. Detach the pipe located below the 4-way valve. Remove the end sections of the pipes above the 4-way valve, which were cut in step 5). Install a new 4-way valve. <ul style="list-style-type: none"> * Provide adequate cover for the 4-way valve to protect it from overheating. During the installation, insert pipes firmly into the 4-way valve, or a blockage or leakage involving brazing filler metal may result. Reinstall the PMV assembly, which was removed in step 4). <ul style="list-style-type: none"> * Provide adequate cover for the PMV to protect it from overheating. Reinstall all the coils removed in step 3), and put the wiring back to its initial state. Reinstall the inverter box in accordance with the installation instructions. Reinstall the lower cabinet. 	<p>For FT8(J)P-E, FT8(J)P-TR, FT8(J)P-UK model</p>  <p>For FT8(J)P, FT7(J)P, FT8P-A model</p> 
For FT8(J)P-E, FT8(J)P-TR, FT8(J)P-UK model			
			
For FT8(J)P, FT7(J)P, FT8P-A model			
			

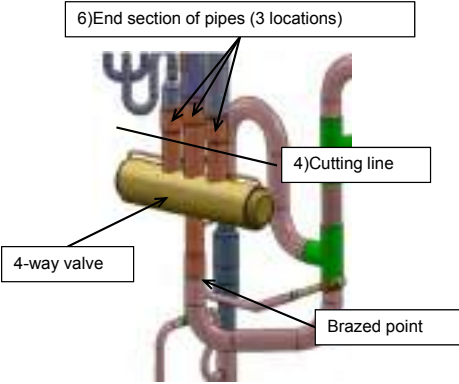
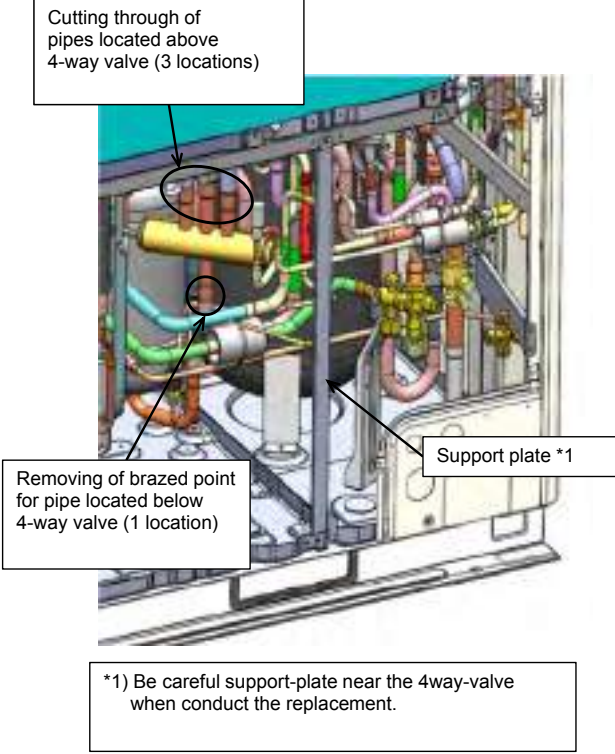
No.	Part to be replaced	Work procedure	Remarks
9	4-way valve - detachment/ attachment (continued) MAP1606* MAP1806* MAP2006*	<p>⚠ WARNING</p> <p>Wear a pair of gloves. Otherwise, you will risk an injury involving a replacement part or some other object.</p> <hr/> <p>Before starting the work, be sure to recover the refrigerant of outdoor unit by removing it with a refrigerant recovery device.</p> <p>1. Detachment</p> <ol style="list-style-type: none"> 1) Remove the lower cabinet (left and right). 2) Remove the inverter box in accordance with the dismantling instructions. 3) Disconnect the 4-way valve coil and get all wiring located near the 4-way valve out of the way. 4) Since it is difficult to simultaneously remove the brazed points for the pipes located above the 4-way valve (3 locations), cut through them just below the brazed points using a saw, etc. 5) Detach the pipe located below the 4-way valve. 6) Remove the end sections of the pipes above the 4-way valve, which were cut in step 5). 7) Install a new 4-way valve. <ul style="list-style-type: none"> * Provide adequate cover for the 4-way valve to protect it from overheating. During the installation, insert pipes firmly into the 4-way valve, or a blockage or leakage involving brazing filler metal may result. 8) Reinstall all the coils removed in step 3), and put the wiring back to its initial state. 9) Reinstall the inverter box in accordance with the installation instructions. 10) Reinstall the lower cabinet. 	 

13 P.C. BOARD EXCHANGE PROCEDURES

■ Outdoor Unit

13-1. Replacement of outdoor P.C. board

13-1-1 List of service P.C. boards

Parts code	Description	Applicable model	P.C. board type code	Product code
43T6W386	Interface P.C. board	MMY-MAP0806FT* MMY-MAP1006FT*	MCC-1673	ASM-PCB(I/F)
43T6V628	Inverter P.C. board for compressor		MCC-1669	ASM-PCB(A3IPDU)
43T6V627	Inverter P.C. board for fan		MCC-1659	ASM-PCB(FANIPDU)
43T6V623	Noise filter P.C. board		MCC-1608-A,B	ASM-PCB(N/F)
43T6V646	Demand Response P.C. board (For MMY-MAP****FT8P-A)		MCC-1653	ASM-PCB(DRC)

Parts code	Description	Applicable model	P.C. board type code	Product code
43T6W386	Interface P.C. board	MMY-MAP1206FT* MMY-MAP1406FT*	MCC-1673	ASM-PCB(I/F)
43T6V629	Inverter P.C. board for compressor		MCC-1669	ASM-PCB(A3IPDU)
43T6V627	Inverter P.C. board for fan		MCC-1659	ASM-PCB(FANIPDU)
43T6V623	Noise filter P.C. board		MCC-1608-A,B	ASM-PCB(N/F)
43T6V646	Demand Response P.C. board (For MMY-MAP****FT8P-A)		MCC-1653	ASM-PCB(DRC)

Parts code	Description	Applicable model	P.C. board type code	Product code
43T6W386	Interface P.C. board	MMY-MAP1606FT* MMY-MAP1806FT* MMY-MAP2006FT*	MCC-1673	ASM-PCB(I/F)
43T6V630	Inverter P.C. board for compressor		MCC-1660	ASM-PCB(A3IPDU)
43T6V627	Inverter P.C. board for fan		MCC-1659	ASM-PCB(FANIPDU)
43T6V624	Noise filter P.C. board (Left side)		MCC-1608-A,B	ASM-PCB(N/F)
43T6V625	Noise filter P.C. board (Right side)		MCC-1608-A,B	ASM-PCB(N/F)
43T6V646	Demand Response P.C. board (For MMY-MAP****HT8P-A)		MCC-1653	ASM-PCB(DRC)

13-1-2 Configuration of inverter assembly

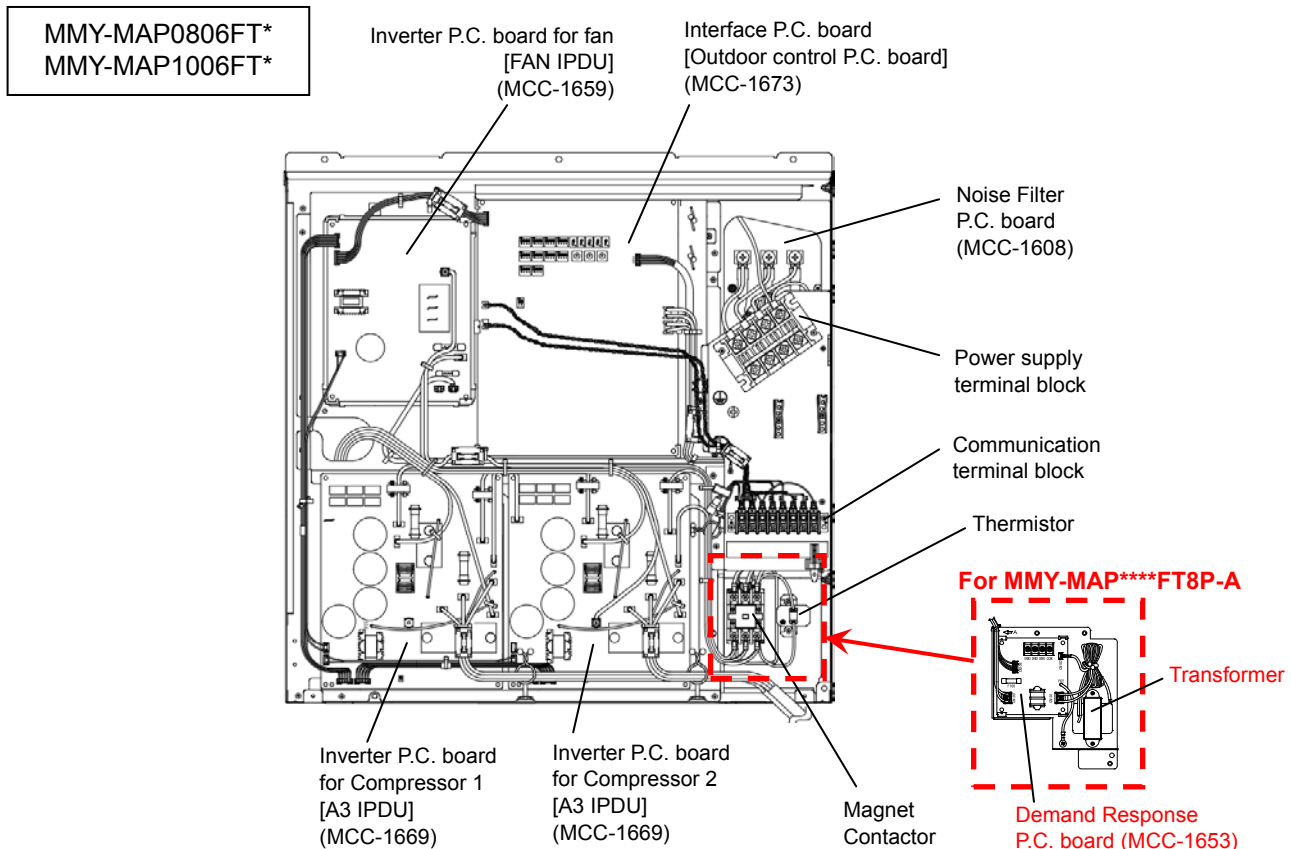

MMY-MAP1206FT*
MMY-MAP1406FT*

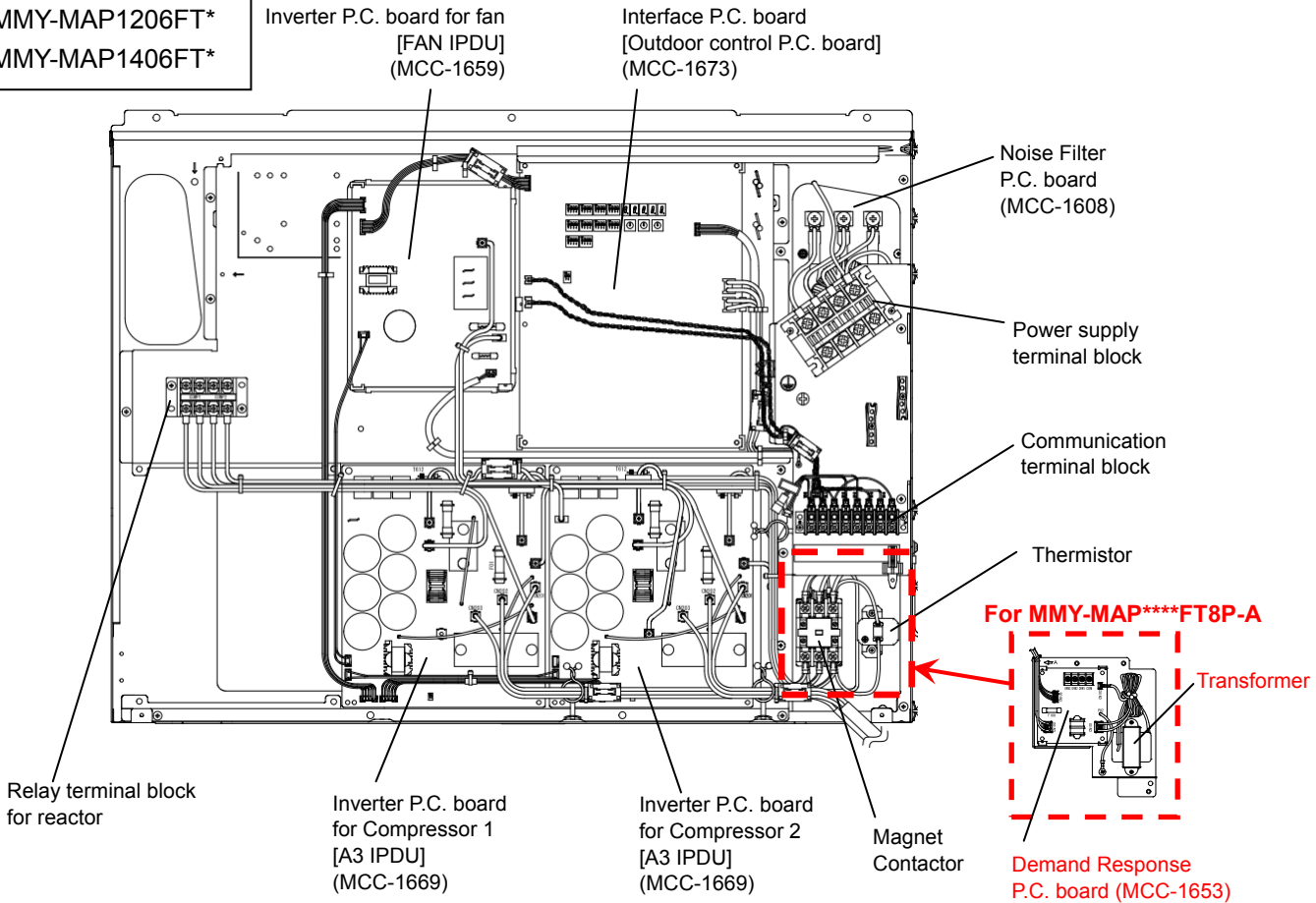

MMY-MAP1606FT*
MMY-MAP1806FT*
MMY-MAP2006FT*

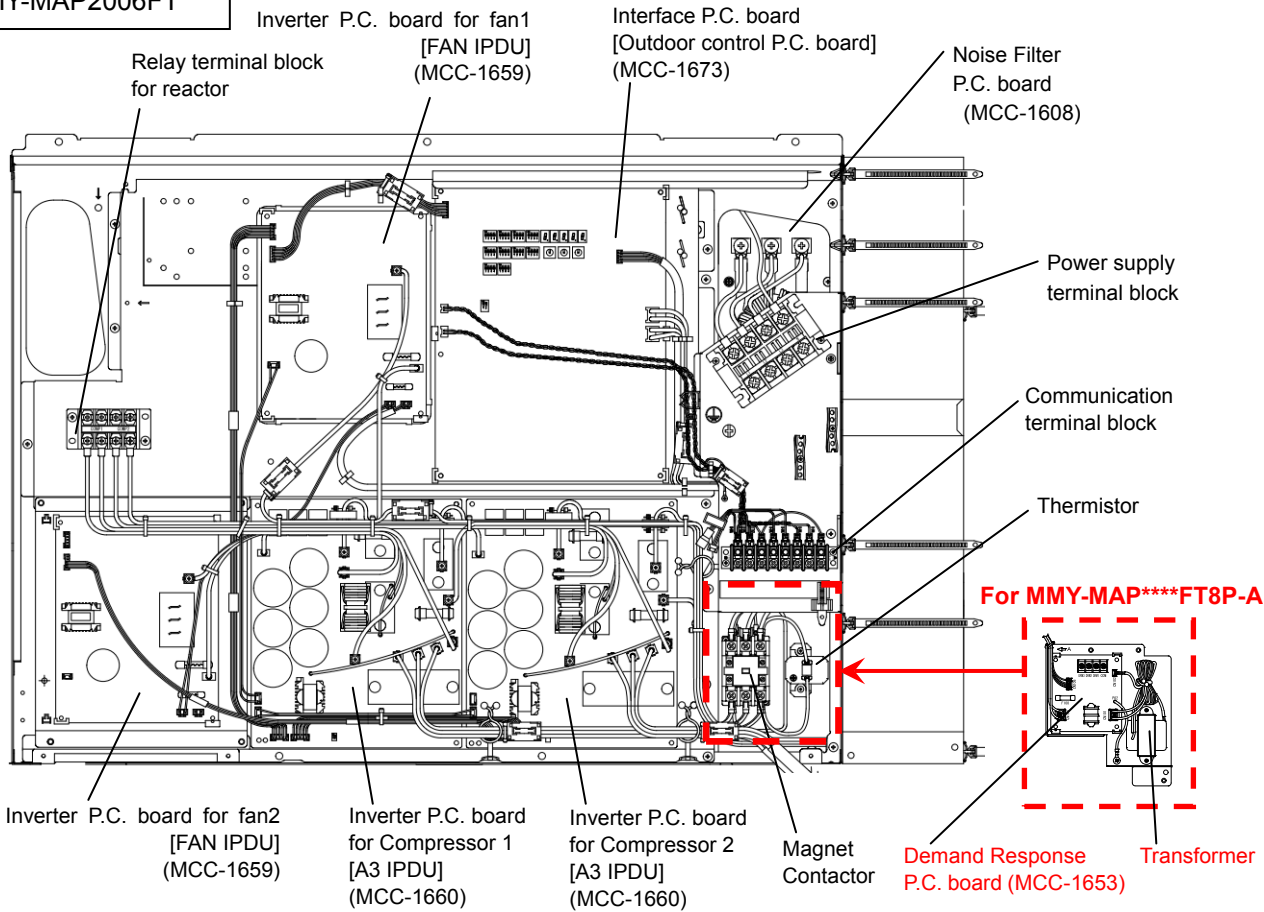

13-1-3.Interface P.C. Board (MCC-1673) Replacement Procedure

This Interface board is commonly installed in different models before shipment. When the board assembly is to be replaced, check the displayed inspection contents below and replace the board in accordance with the model, following the below procedure.

Replacement steps:

- (1) Turn off the power supply of the outdoor unit and wait at least 3 minutes.
- (2) Remove all of the connectors connected to the interface board. (Remove the connectors by pulling the connector body. Do not pull the wire).
- (3) Remove the interface board from the six PCB mounts (①).
- (4) Cut the jumper wires of the service board, as instructed in the table below.
The jumper setting differs from original supplied PCB, therefore be sure to configure the Jumpers as in the table below.
If the model is not specified, check code "L10" is displayed and the equipment will not operate.

Model name	Model size	J09	J10	J11	J12	J22	J27
Service P.C. Board		Yes	Yes	Yes	Yes	Yes	Yes
MMY-MAP0806FT8(J)P-E/-TR/-UK	990W	Cut	Cut	—	—	Cut	—
MMY-MAP1006FT8(J)P-E/-TR/-UK		—	Cut	—	—	Cut	—
MMY-MAP1206FT8(J)P-E/-TR/-UK	1210W	Cut	—	—	—	Cut	—
MMY-MAP1406FT8(J)P-E/-TR/-UK		Cut	Cut	Cut	Cut	Cut	—
MMY-MAP1606FT8(J)P-E/-TR/-UK	1600W	—	Cut	Cut	Cut	Cut	—
MMY-MAP1806FT8(J)P-E/-TR/-UK		Cut	—	Cut	Cut	Cut	—
MMY-MAP2006FT8(J)P-E/-TR/-UK		—	—	Cut	Cut	Cut	—
MMY-MAP0806FT8/7(J)P*	990W	Cut	Cut	—	—	Cut	Cut
MMY-MAP1006FT8/7(J)P*		—	Cut	—	—	Cut	Cut
MMY-MAP1206FT8/7(J)P*	1210W	Cut	—	—	—	Cut	Cut
MMY-MAP1406FT8/7(J)P*		Cut	Cut	Cut	Cut	Cut	Cut
MMY-MAP1606FT8/7(J)P*	1600W	—	Cut	Cut	Cut	Cut	Cut
MMY-MAP1806FT8/7(J)P*		Cut	—	Cut	Cut	Cut	Cut
MMY-MAP2006FT8/7(J)P*		—	—	Cut	Cut	Cut	Cut

* The characters in accordance with the destination may attach to the end of model name. (Blank, -A)

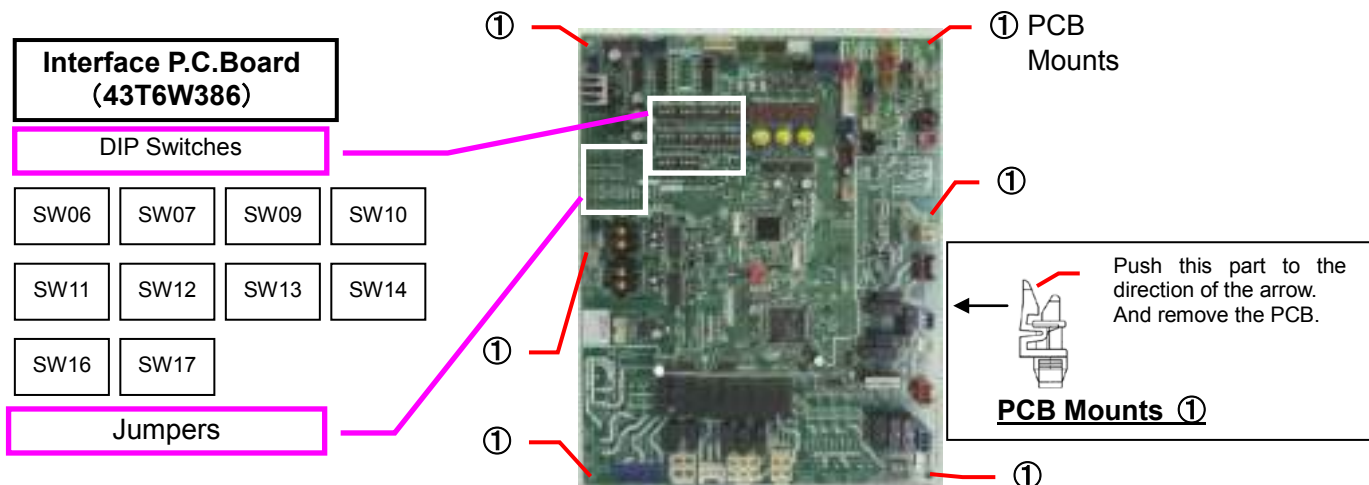

- (5) Set the DIP switch settings of the service board to match the switch settings of the PCB being replaced.
- (6) Install the service board to the outdoor control unit (Confirm that it is securely fixed to the PCB Mounts).
- (7) Connect the connectors (Confirm that they are correctly and securely inserted).
- (8) If a component on the board is bent during board replacement, adjust it manually ensuring that it is not short or contact other parts.
- (9) Install the cover, then turn on the power supply. Check the operation.

13-1-4.Comp-IPDU P.C. Board (MCC-1669) Replacement Procedure <8 to 10HP outdoor unit case>

This board is commonly installed in different models before shipment. Set the DIP switch (SW800) setting of the service board to the switch setting before replacement.

Replacement Steps:

- (1) Turn off the power supply of the outdoor unit and allow at least 3 minutes for the capacitor to discharge.
- (2) Remove all the connectors and the Faston and screw terminals(①) connected to the Compressor IPDU.
(Remove the connectors by pulling the connector body. Do not pull the wire).
- (3) Remove all the four screws(②) which secures the Compressor IPDU to the Heat sink.
(These screws are to be re-used after procedure.)
- (4) Remove the Compressor IPDU from the four spacers (③) by pinching the top of the spacers by round-nose pliers.

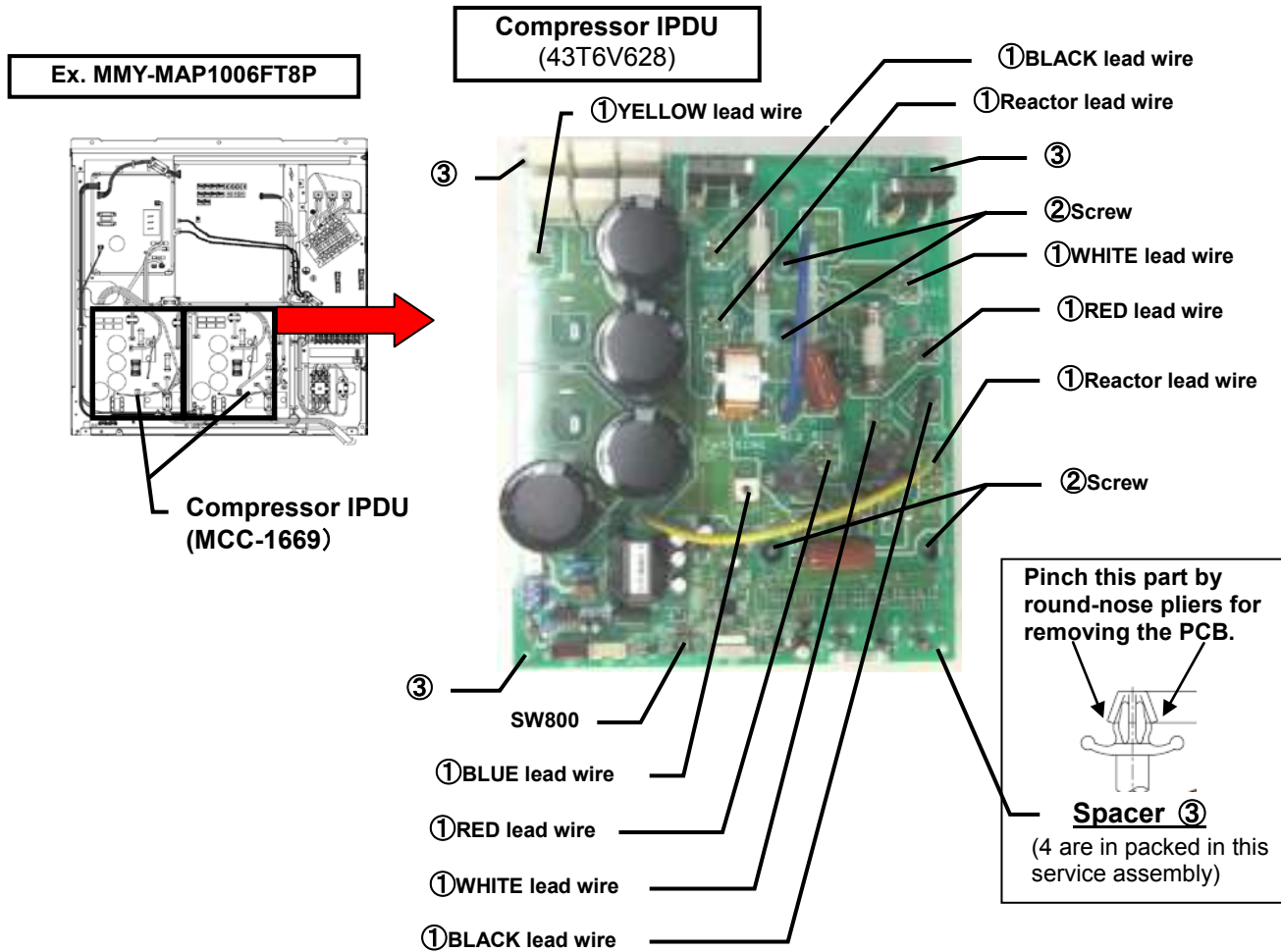

- (5) Set the DIP switch (SW800) setting of the service board to match the switch setting from the original PCB.
 -Set the DIP switch (SW800) depending on the position of the IPDU within the electrical box, as shown in the following diagram.

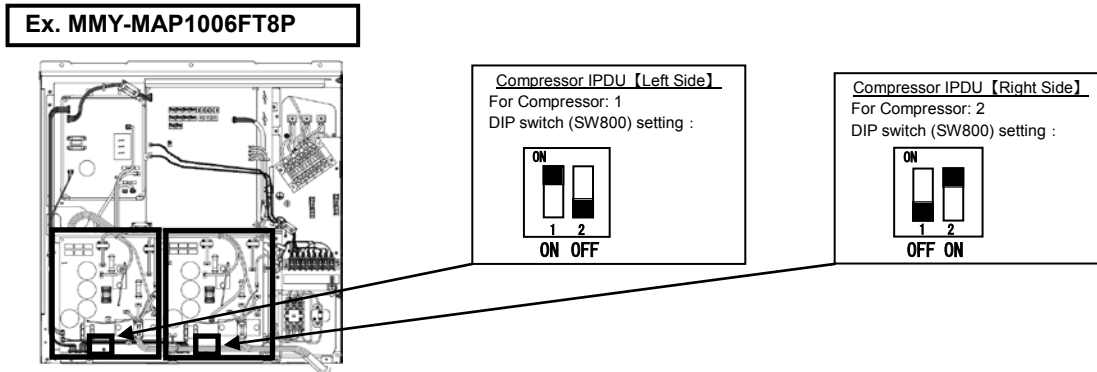

- (6) Apply the Silicone Thermal Grease to the semiconductors (DB01, Q201) on the service PC board, and align the positions of the heat sink holes to mount the Compressor IPDU on the outdoor control unit. And fix the Compressor IPDU to the outdoor control unit by the spacers (③).

Uniformly apply the Silicone Thermal Grease to the heat dissipating surfaces of the IPM (Q201) and rectifier (DB01).
 Note: Do this work carefully since allowing any dirt, scratches, etc. to be left on the PC board mounting areas of the semiconductors will impair the heat dissipation effect and may result in a failure.

Silicone Thermal Grease use one of the following

- Momentive Performance Materials "TIG1000"
- Dow Corning Toray "SC102"
- Mizutani Electric Ind "HSC1000"
- Shin-Etsu Chemical "G-746" or "G-747"

- (7) Screw the Compressor IPDU to the heat sink by the four screws that were removed in step (3). If the screws are loose, the effect component will generate heat, and cause it to breakdown. Do not use an electric driver or an air driver. As it can cause component damage. The torque of the screws for DB01 and Q201 is "1.2Nm".

- (8) Re-connect the connectors and Faston and screw terminals(①).
 Be sure that all the connectors and the screw terminals are connected correctly and securely inserted.

Note: ①When connecting the white lead wire which is connected to CN02, be absolutely sure that it is passed through the T611 transformer and then connected
 ②When connecting the black lead wire which is connected to CN03, be absolutely sure that it is passed through the T612 transformer and then connected
 (If it is not passed through the transformer, it will not be possible for the input current level to be measured correctly, and a compressor failure may result.)

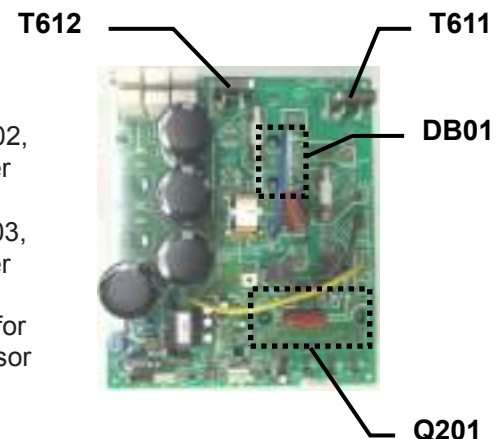

- (9) If the components on the PCB were bent during this procedure, straighten them so they do not touch other parts.

- (10) Install the cover, then turn on the supply. Check the operation.

13-1-5.Comp-IPDU P.C. Board (MCC-1669) Replacement Procedure <12 to 14HP outdoor unit case>

This board is commonly installed in different models before shipment. Set the DIP switch (SW800) setting of the service board to the switch setting before replacement.

Replacement Steps:

- (1) Turn off the power supply of the outdoor unit and allow at least 3 minutes for the capacitor to discharge.
- (2) Remove all the connectors and the Faston and screw terminals(①) connected to the Compressor IPDU.
(Remove the connectors by pulling the connector body. Do not pull the wire).
- (3) Remove all the four screws(②) which secures the Compressor IPDU to the Heat sink.
(These screws are to be re-used after procedure.)
- (4) Remove the Compressor IPDU from the four spacers (③) by pinching the top of the spacers by round-nose pliers.

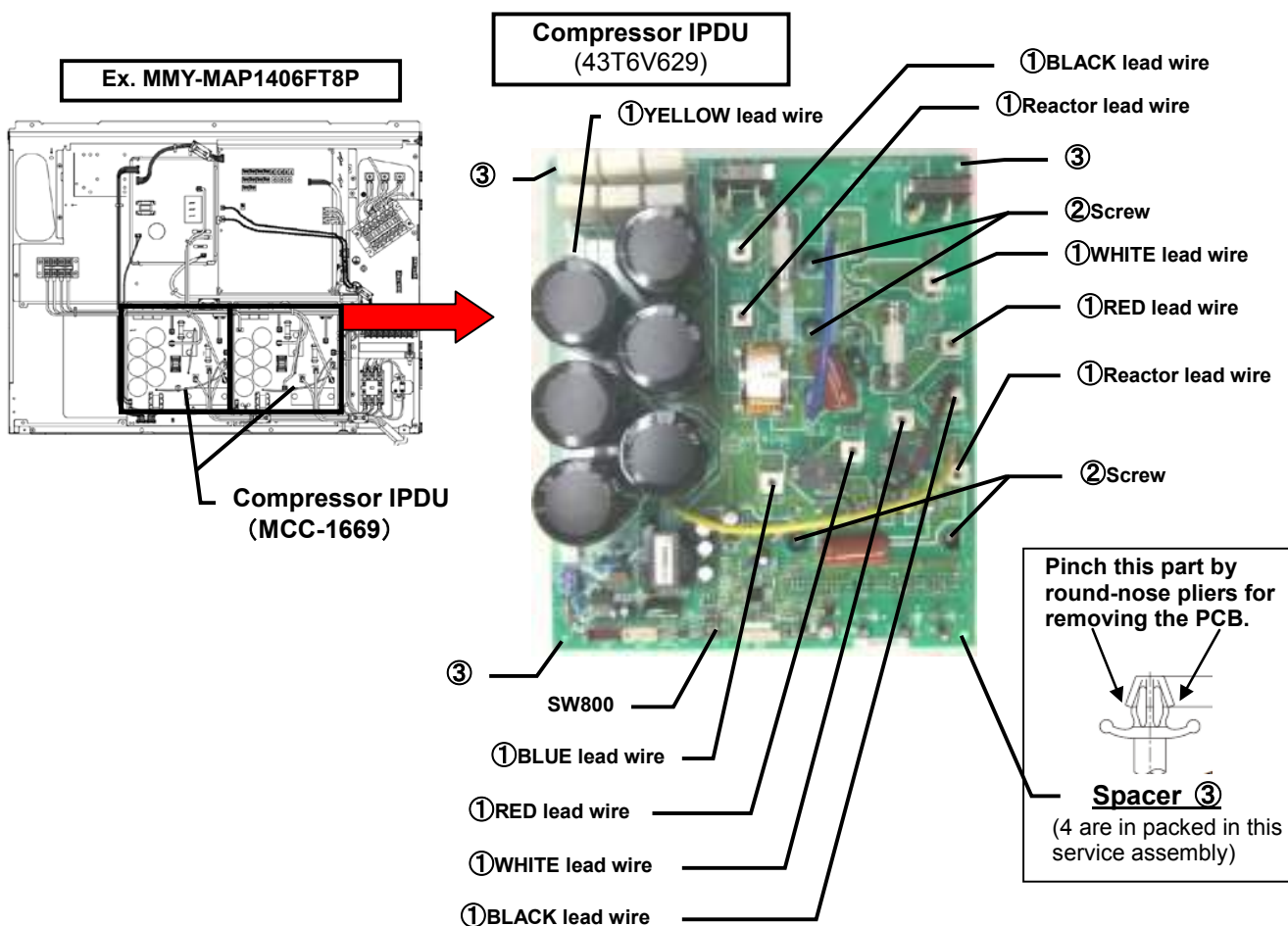

- (5) Set the DIP switch (SW800) setting of the service board to match the switch setting from the original PCB.
 -Set the DIP switch (SW800) depending on the position of the IPDU within the electrical box, as shown in the following diagram.

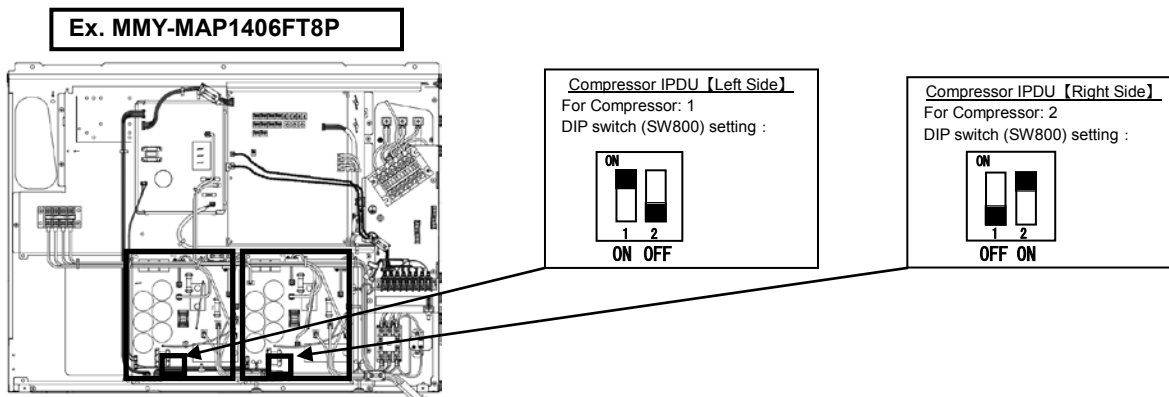

- (6) Apply the Silicone Thermal Grease to the semiconductors (DB01, Q201) on the service PC board, and align the positions of the heat sink holes to mount the Compressor IPDU on the outdoor control unit. And fix the Compressor IPDU to the outdoor control unit by the spacers (③).

Uniformly apply the Silicone Thermal Grease to the heat dissipating surfaces of the IPM (Q201) and rectifier (DB01).
 Note: Do this work carefully since allowing any dirt, scratches, etc. to be left on the PC board mounting areas of the semiconductors will impair the heat dissipation effect and may result in a failure.

Silicone Thermal Grease use one of the following

- Momentive Performance Materials "TIG1000"
- Dow Corning Toray "SC102"
- Mizutani Electric Ind "HSC1000"
- Shin-Etsu Chemical "G-746" or "G-747"

- (7) Screw the Compressor IPDU to the heat sink by the four screws that were removed in step (3). If the screws are loose, the effect component will generate heat, and cause it to breakdown. Do not use an electric driver or an air driver. As it can cause component damage. The torque of the screws for DB01 and Q201 is "1.2Nm".

- (8) Re-connect the connectors and Faston and screw terminals(①).
 Be sure that all the connectors and the screw terminals are connected correctly and securely inserted.

Note: ①When connecting the white lead wire which is connected to CN02, be absolutely sure that it is passed through the T611 transformer and then connected

②When connecting the black lead wire which is connected to CN03, be absolutely sure that it is passed through the T612 transformer and then connected
 (If it is not passed through the transformer, it will not be possible for the input current level to be measured correctly, and a compressor failure may result.)

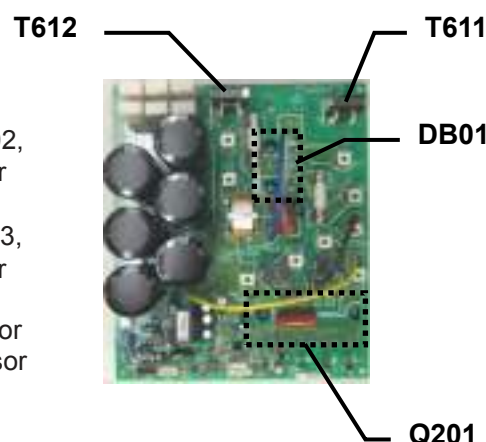

- (9) If the components on the PCB were bent during this procedure, straighten them so they do not touch other parts.

- (10) Install the cover, then turn on the supply. Check the operation.

13-1-6.Comp-IPDU P.C. Board (MCC-1660) Replacement Procedure <16 to 20HP outdoor unit case>

This board is commonly installed in different models before shipment. Set the DIP switch (SW800) setting of the service board to the switch setting before replacement.

Replacement Steps:

- (1) Turn off the power supply of the outdoor unit and allow at least 3 minutes for the capacitor to discharge.
- (2) Remove all the connectors and the Faston and screw terminals(①) connected to the Compressor IPDU.
(Remove the connectors by pulling the connector body. Do not pull the wire).
- (3) Remove all the eight screws(②) which secures the Compressor IPDU to the Heat sink.
(These screws are to be re-used after procedure.)
- (4) Remove the Compressor IPDU from the four spacers (③) by pinching the top of the spacers by round-nose pliers.

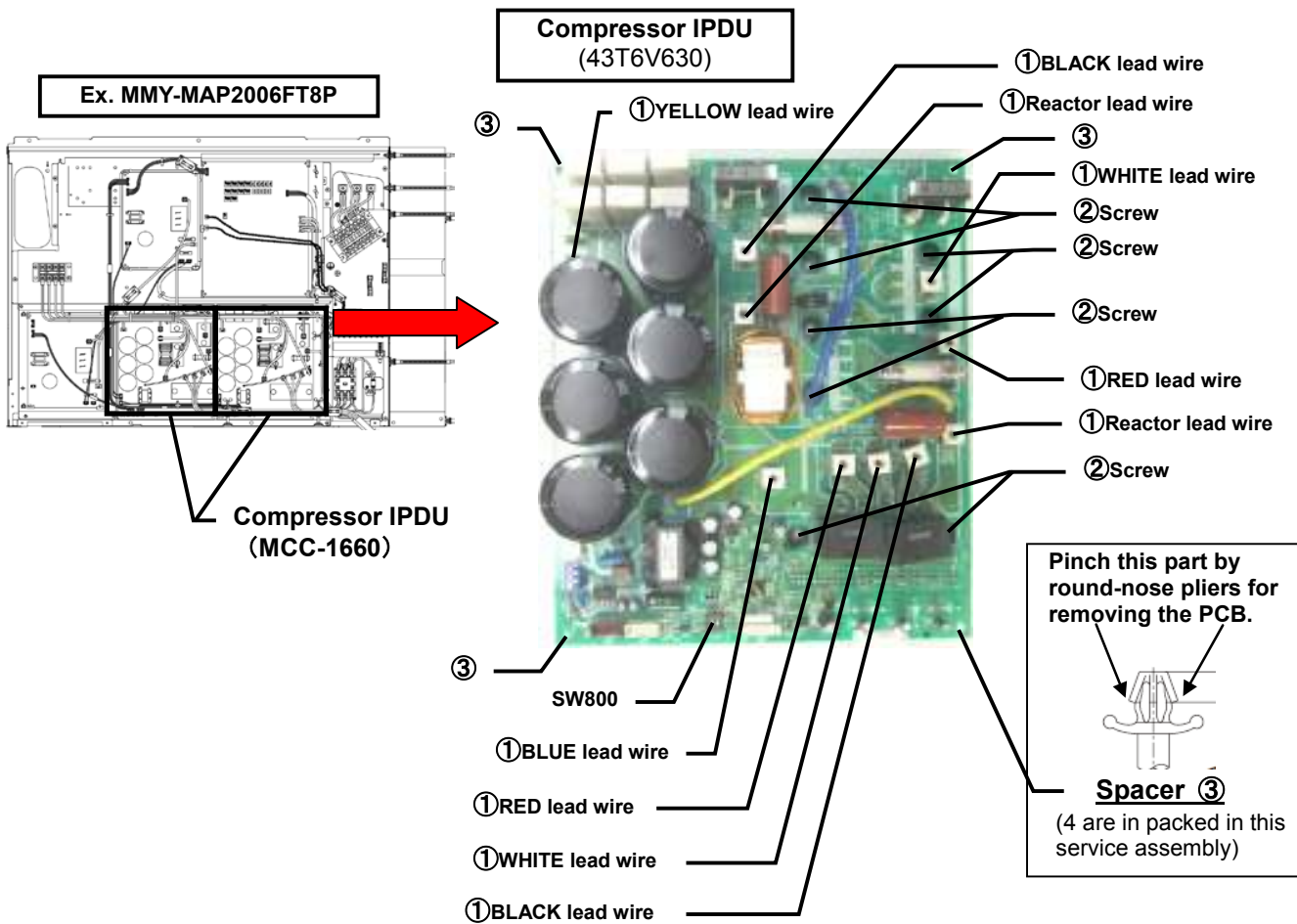

- (5) Set the DIP switch (SW800) setting of the service board to match the switch setting from the original PCB.
 -Set the DIP switch (SW800) depending on the position of the IPDU within the electrical box, as shown in the following diagram.

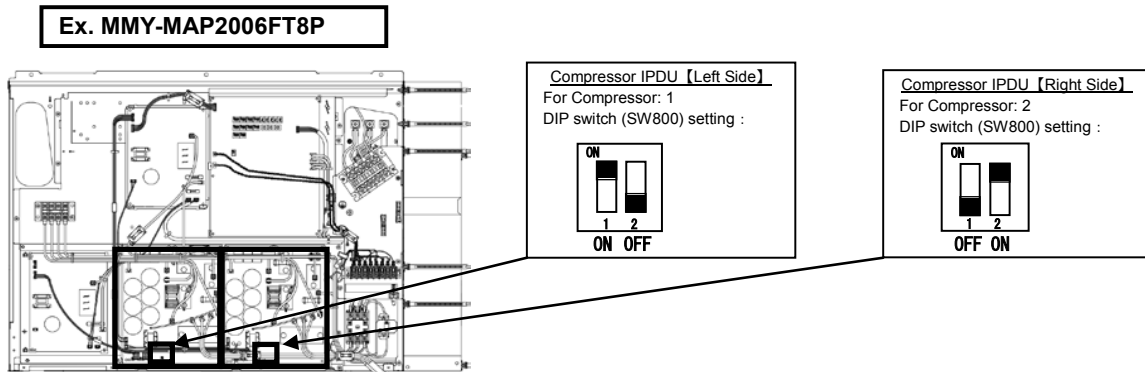

- (6) Apply the Silicone Thermal Grease to the semiconductors (DB01, DB02, DB03, Q201) on the service PC board, and align the positions of the heat sink holes to mount the Compressor IPDU on the outdoor control unit. And fix the Compressor IPDU to the outdoor control unit by the spacers (3).

Uniformly apply the Silicone Thermal Grease to the heat dissipating surfaces of the IPM (Q201) and rectifier (DB01, DB02, DB03).
 Note: Do this work carefully since allowing any dirt, scratches, etc. to be left on the PC board mounting areas of the semiconductors will impair the heat dissipation effect and may result in a failure.

Silicone Thermal Grease use one of the following
 •Momentive Performance Materials "TIG1000"
 •Dow Corning Toray "SC102"
 •Mizutani Electric Ind "HSC1000"
 •Shin-Etsu Chemical "G-746" or "G-747"

- (7) Screw the Compressor IPDU to the heat sink by the eight screws that were removed in step (3). If the screws are loose, the effect component will generate heat, and cause it to breakdown. Do not use an electric driver or an air driver. As it can cause component damage. The torque of the screws for DB01, DB02, DB03 and Q201 is "1.2Nm".

- (8) Re-connect the connectors and Faston and screw terminals(1).
 Be sure that all the connectors and the screw terminals are connected correctly and securely inserted.

- Note:** ①When connecting the lead wire, don't touch PCB part of the T202 transformer.
 ②When connecting the white lead wire which is connected to CN02, be absolutely sure that it is passed through the T611 transformer and then connected.
 ③When connecting the black lead wire which is connected to CN03, be absolutely sure that it is passed through the T612 transformer and then connected.
 ④When connecting the red lead wire which is connected to CN203, be absolutely sure that it is passed through the T201 transformer and then connected.
 ⑤When connecting the white lead wire which is connected to CN202, be absolutely sure that it is passed through the T202 transformer and then connected.
 (If it is not passed through the transformer, it will not be possible for the input current level to be measured correctly, and a compressor failure may result.)

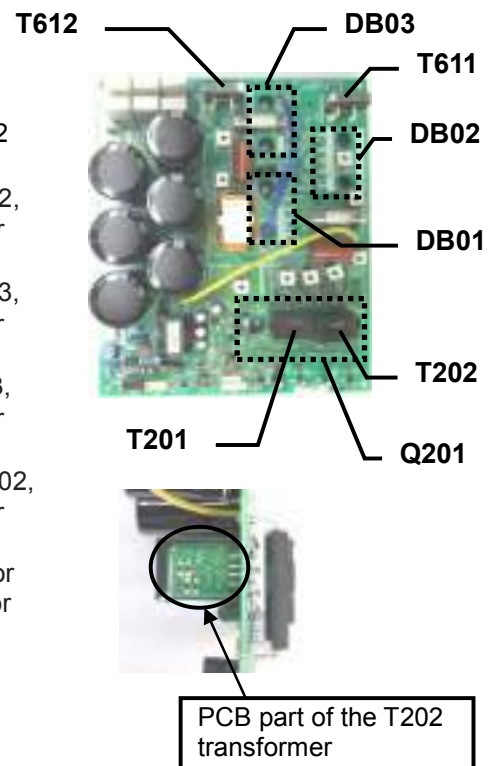

- (9) If the components on the PCB were bent during this procedure, straighten them so they do not touch other parts.
 (10) Install the cover, then turn on the supply. Check the operation.

13-1-7.Fan-IPDU P.C. Board (MCC-1659) Replacement Procedure

This board is commonly installed in different models before shipment. Set the DIP switch (SW800) setting of the service board to the switch setting before replacement.

Replacement steps:

- (1) Turn off the power supply of the outdoor unit and allow at least 3 minutes for the capacitor to discharge.
- (2) Remove all the connectors and the Faston and screw terminals(①) connected to the FAN IPDU.
(Remove the connectors and Faston terminals by pulling the connector body. Do not pull the wire).
- (3) Remove all the two screws(②) which secures the FAN IPDU to the Heat sink.
(These screws are to be re-used after procedure.)
- (4) Remove the Fan IPDU from the four PCB Mounts (③).

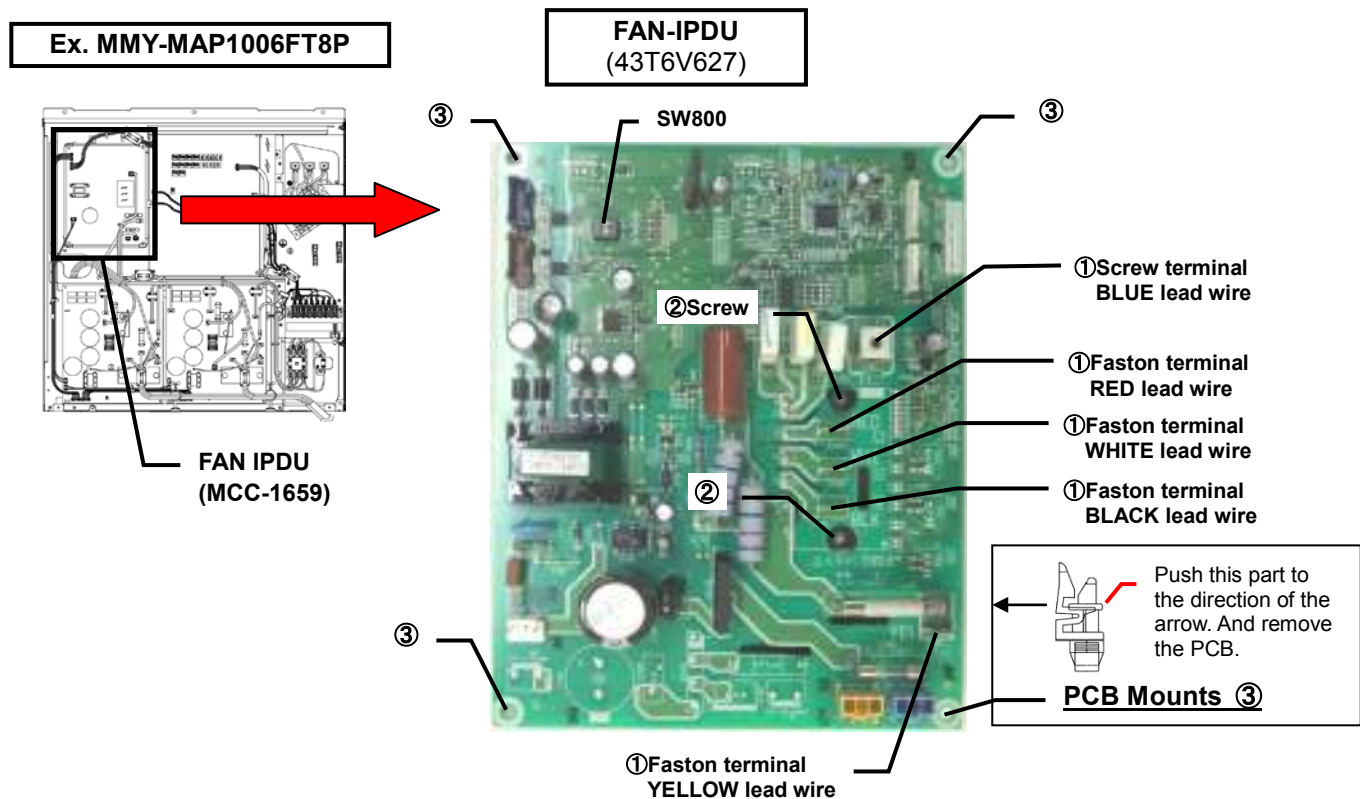

- (5) Confirm that no dirt or damage is on the sub heat sink. As it can reduce the heat transfer efficiency, and cause a breakdown.

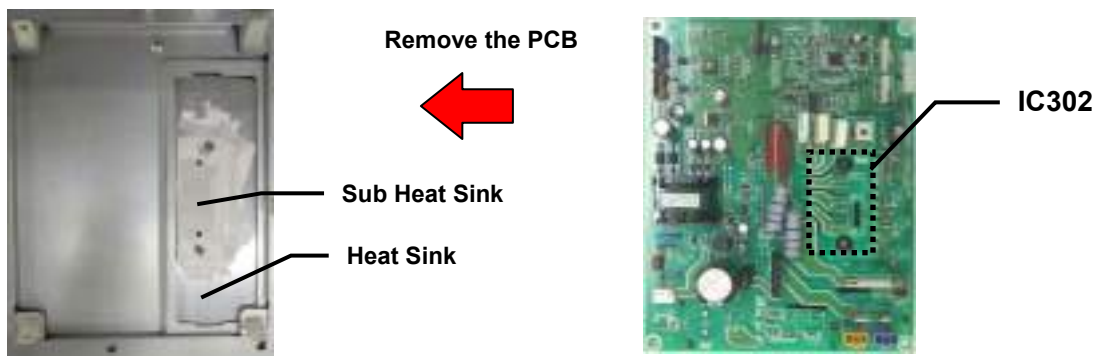

- (6) Set the DIP switch (SW800) setting of the service board to match the switch setting from the original PCB.
 -Set the DIP switch (SW800) depending on the position of the IPDU within the electrical box, as shown in the following diagram.

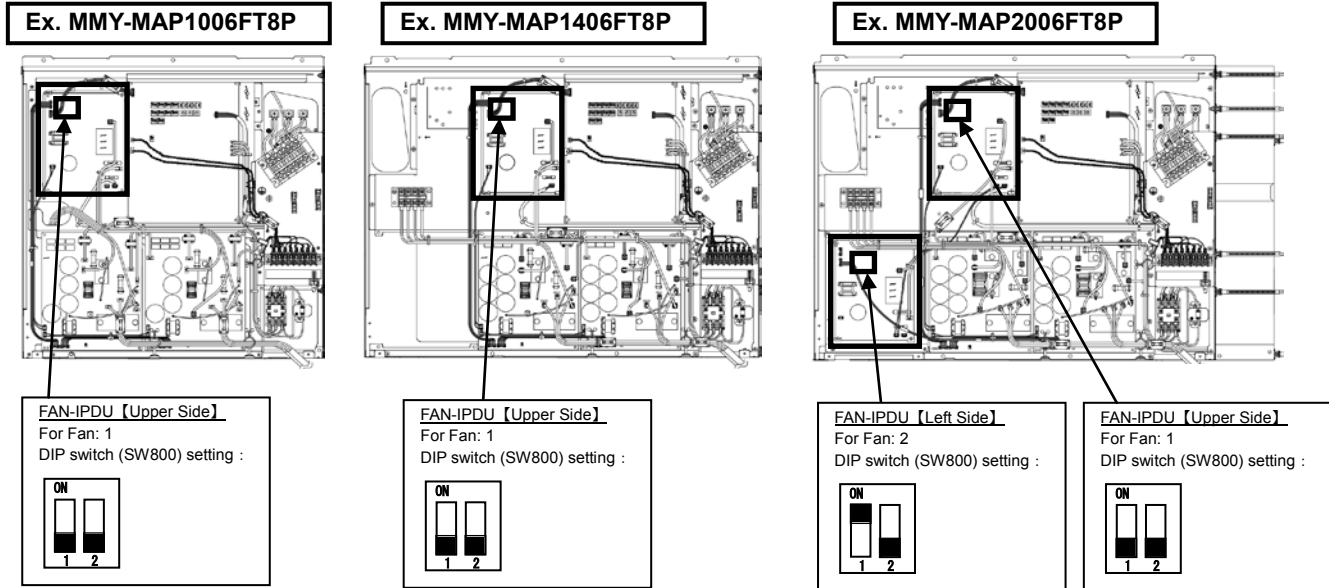

- (6) Apply the Silicone Thermal Grease to the semiconductors (IC302) on the service PC board, and align the PCB mount holes on the PCB with the PCB mounts, and fix the FAN IPDU to the outdoor control unit by clipping the PCB into the PCB mounts (③).

Uniformly apply the Silicone Thermal Grease to the heat dissipating surfaces of the IPM (IC302). .
 Note: Do this work carefully since allowing any dirt, scratches, etc. to be left on the PC board mounting areas of the semiconductors will impair the heat dissipation effect and may result in a failure.

Silicone Thermal Grease use one of the following
 •Momentive Performance Materials "TIG1000"
 •Dow Corning Toray "SC102"
 •Mizutani Electric Ind "HSC1000"
 •Shin-Etsu Chemical "G-746" or "G-747"

- (7) Screw the FAN IPDU to the heat sink by the two screws that were removed in step (3). If the screws are loose, the effected component will generate heat, and cause in to breakdown. Do not use an electric driver or an air driver, as it can cause component damage. The torque of 2 screws (IC302) is "0.55Nm".
- (8) Re-connect the connectors and Faston and screw terminals(①). Be sure that all the connectors and the Faston terminals are connected correctly and securely inserted.
- (9) If the components on the PCB were bent during this procedure, straighten them so they do not to touch other parts.
- (10) Install the cover, then turn on the supply. Check the operation.

13-1-8.Noise Filter P.C. Board (MCC-1608A, B) Replacement Procedure <8 to 14HP outdoor unit case>

Replacement steps:

- (1) Turn off the power supply of the outdoor unit and allow at least 3 minutes for the capacitor to discharge.
- (2) Remove the terminal block sub-assembly ①.
Remove the screws ② on the power supply terminal block ④ and the screws ③ securing the terminal block subassembly ①.
• The screws will be reused during the installation of the service P.C. board, so keep them in a safe place.

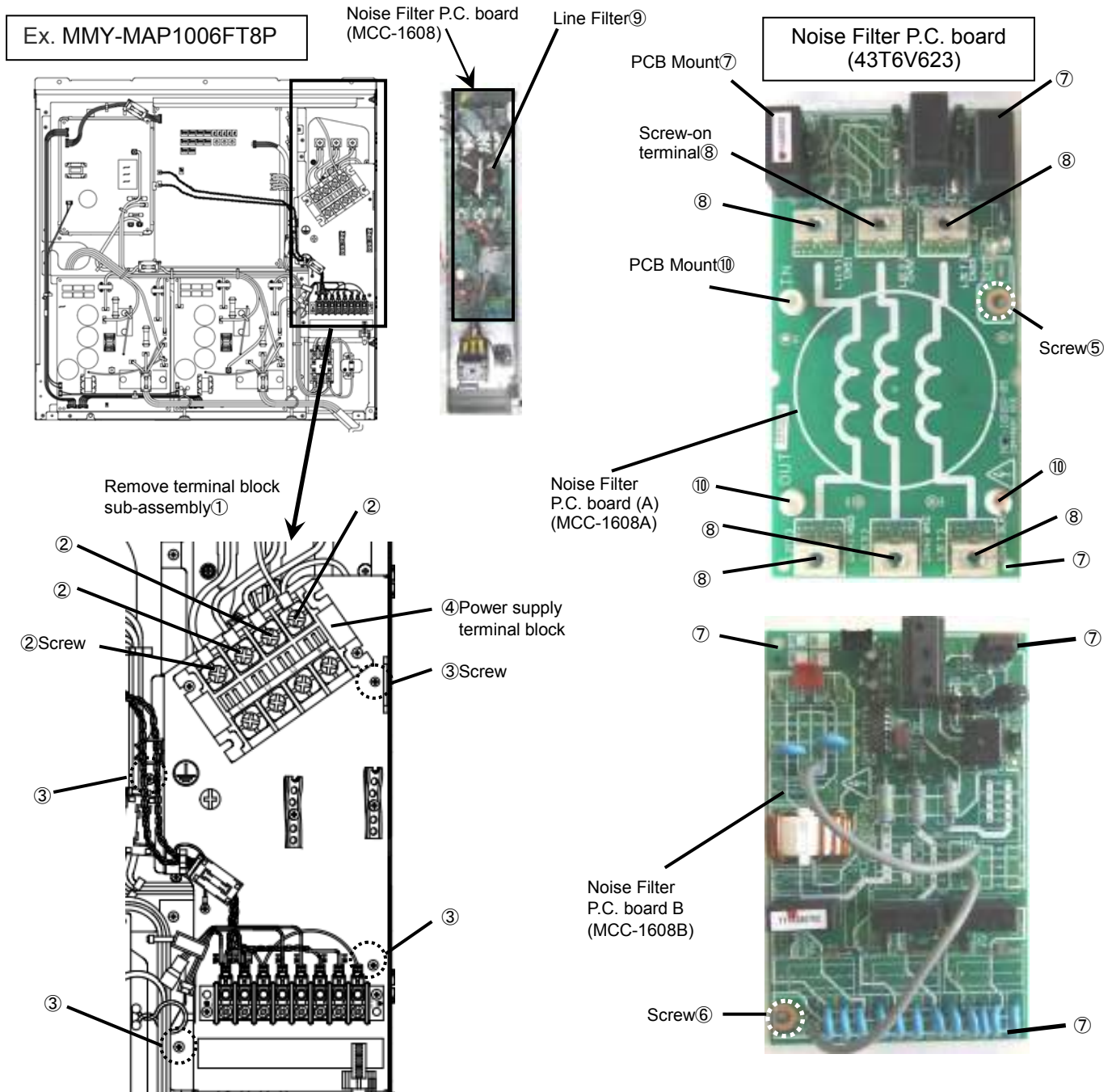

- (3) Disconnect all the connectors and Faston terminals used to connect wiring to the noise filter P.C. board.
• The line filter ⑨ and its leads, both connected to the screw-on terminals ⑧ of the noise filter P.C. board (A) will be removed in step 6.
• Disconnect all the connectors and Faston terminals.

- (4) Remove the earth screws ⑤, ⑥ and the three PCB mount ⑩.
 - The removed earth screws ⑤, ⑥ and the PCB mount ⑩ will be reused during the installation of the service P.C. board, so keep them in a safe place.
- (5) Remove the noise filter P.C. board assembly by unlocking the four PCB mounts used to secure the P.C. board ⑦.
- (6) Remove the line filter ⑨ and its leads, both connected to the screw-on terminals ⑧ of the just-removed noise filter P.C. board (A), and reinstall them on the service P.C. board (A) by firmly connecting them to the screw-on terminals ⑧ in the same manner as before.
- (7) Install the service P.C. boards (A) and (B) in the outdoor unit controller. (Make sure that they are firmly secured to the PCB mounts ⑦ and ⑩.)

Line Filter installation:

Screw the line filter and the connecting wires together to the terminals as right figure. The torque of 6 screws of the line filter is "1.84ft·lbs (2.5Nm)".

Please check that the screws connecting the line filter are not loose. If the screw is loose, the screw will generate heats, and cause the line filter to breakdown.

Do not use an electric driver or an air driver, as this can cause damage to the line filter.

Connect the wires according to the wiring diagram.

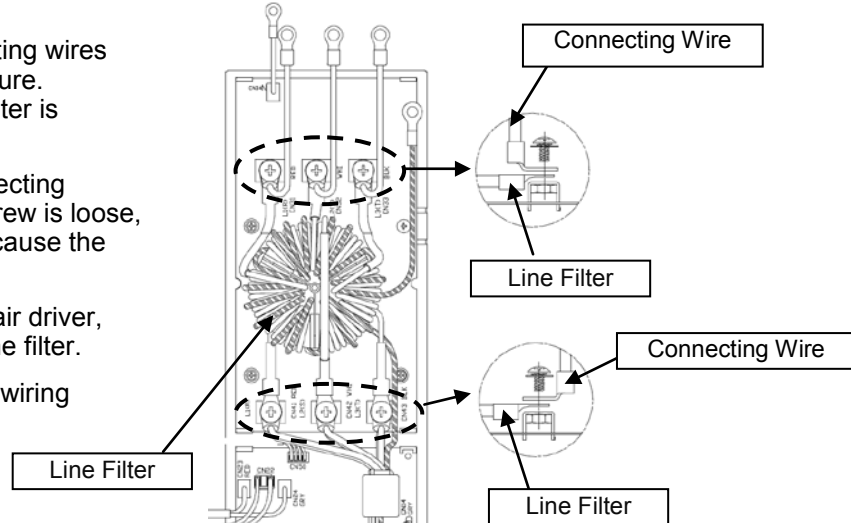

- (8) Securely connect the service P.C. boards to the chassis using the earth screws ⑤, ⑥ removed in step (4). If either of the screws is loose, it will pose a risk of device failure by degrading noise control, so take care while engaging in the work. Nevertheless, do not use an electric or pneumatic screwdriver under any circumstances as it may lead to component damage.
- (9) Connect the wiring using the connectors and Fastons removed in step (3). Make sure that the connectors and Fastons are connected correctly and securely.
- (10) If any component on the P.C. board becomes crooked during replacement, straighten it without touching any other component.
- (11) Mount the terminal block sub-assembly ① and firmly secure it using the screws ③.
- (12) Securely connect the red, white and black leads from the service P.C. board (A) to the power supply terminal block ④ using the screws ②.
- (13) Put the cover on, turn on the power, and check operation.



Close-up view of screw-on terminals ⑧

Screw tightening torque (N•m)

Screw diameter	Torque (N•m)
M6	2.5±0.1
M4	1.2±0.1
M3	0.5±0.1



Close-up view of terminal block sub-assembly

13-1-9.Noise Filter P.C. Board (MCC-1608A, B) Replacement Procedure <16 to 20HP outdoor unit case (Left side of Noise Filter Box)>

Replacement steps:

- (1) Turn off the power supply of the outdoor unit and allow at least 3 minutes for the capacitor to discharge.
- (2) Remove the terminal block sub-assembly ①.
Remove the screws ② on the power supply terminal block ④ and the screws ③ securing the terminal block subassembly ①.
• The screws will be reused during the installation of the service P.C. board, so keep them in a safe place.

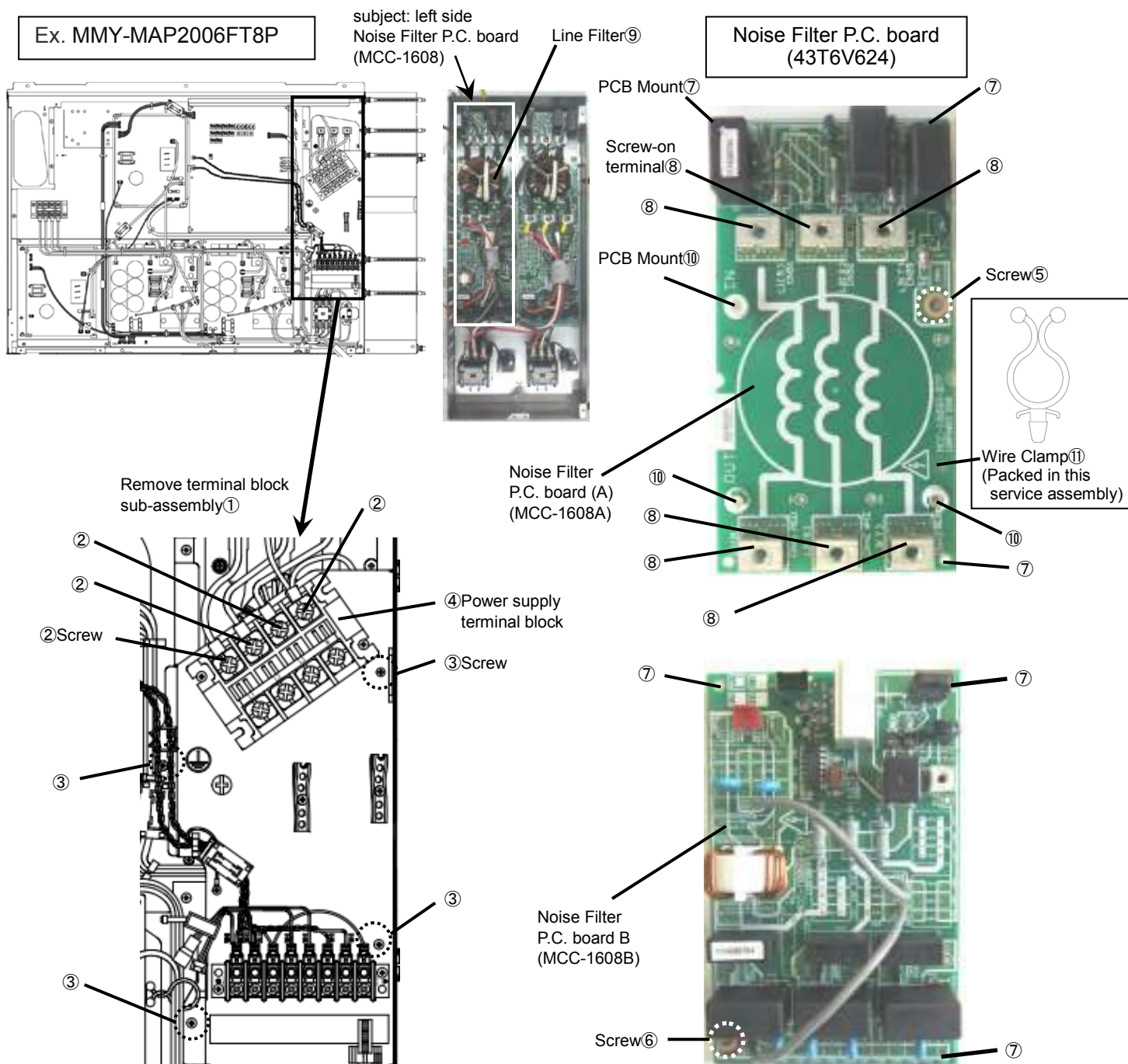

- (3) Disconnect all the connectors and Faston terminals used to connect wiring to the noise filter P.C. board.
• The line filter ⑨ and its leads, both connected to the screw-on terminals ⑧ of the noise filter P.C. board (A) will be removed in step 6.
• Disconnect all the connectors and Faston terminals.

- (4) Remove the earth screws ⑤, ⑥ and the three PCB mount ⑩.
 - The removed earth screws ⑤, ⑥ and the PCB mount ⑩ will be reused during the installation of the service P.C. board, so keep them in a safe place.
- (5) Remove the noise filter P.C. board assembly by unlocking the four PCB mounts used to secure the P.C. board ⑦.
- (6) Remove the line filter ⑨ and its leads, both connected to the screw-on terminals ⑧ of the just-removed noise filter P.C. board (A), and reinstall them on the service P.C. board (A) by firmly connecting them to the screw-on terminals ⑧ in the same manner as before.
- (7) Install the service P.C. boards (A) and (B) in the outdoor unit controller. Insert wire clamp ⑪ into the hole of P.C. board (A) (Make sure that they are firmly secured to the PCB mounts ⑦ and ⑩.)

Line Filter installation:

Screw the line filter and the connecting wires together to the terminals as right figure. The torque of 6 screws of the line filter is "1.84ft·lbs (2.5Nm)".

Please check that the screws connecting the line filter are not loose. If the screw is loose, the screw will generate heats, and cause the line filter to breakdown.

Do not use an electric driver or an air driver, as this can cause damage to the line filter.

Connect the wires according to the wiring diagram.

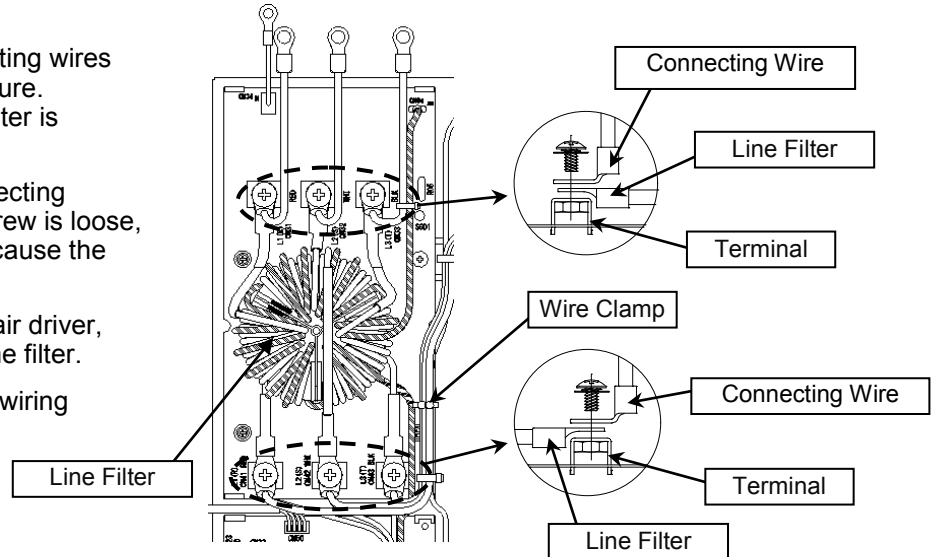

- (8) Securely connect the service P.C. boards to the chassis using the earth screws ⑤, ⑥ removed in step (4). If either of the screws is loose, it will pose a risk of device failure by degrading noise control, so take care while engaging in the work. Nevertheless, do not use an electric or pneumatic screwdriver under any circumstances as it may lead to component damage.
- (9) Connect the wiring using the connectors and Fastons removed in step (3). Make sure that the connectors and Fastons are connected correctly and securely.
- (10) If any component on the P.C. board becomes crooked during replacement, straighten it without touching any other component.
- (11) Mount the terminal block sub-assembly ① and firmly secure it using the screws ③.
- (12) Securely connect the red, white and black leads from the service P.C. board (A) to the power supply terminal block ④ using the screws ②.
- (13) Put the cover on, turn on the power, and check operation.



Close-up view of screw-on terminals ⑧

Screw tightening torque (N·m)

Screw diameter	Torque (N·m)
M6	2.5±0.1
M4	1.2±0.1
M3	0.5±0.1



close-up view of terminal block sub-assembly

13-1-10.Noise Filter P.C. Board (MCC-1608A, B) Replacement Procedure <16 to 20HP outdoor unit case (Right side of Noise Filter Box)>

Replacement steps:

- (1) Turn off the power supply of the outdoor unit and allow at least 3 minutes for the capacitor to discharge.
- (2) Remove the filter cover ①.
Remove the screws ② on the Inverter assembly securing the filter cover ①.
• The screws will be reused during the installation of the service P.C. board, so keep them in a safe place.

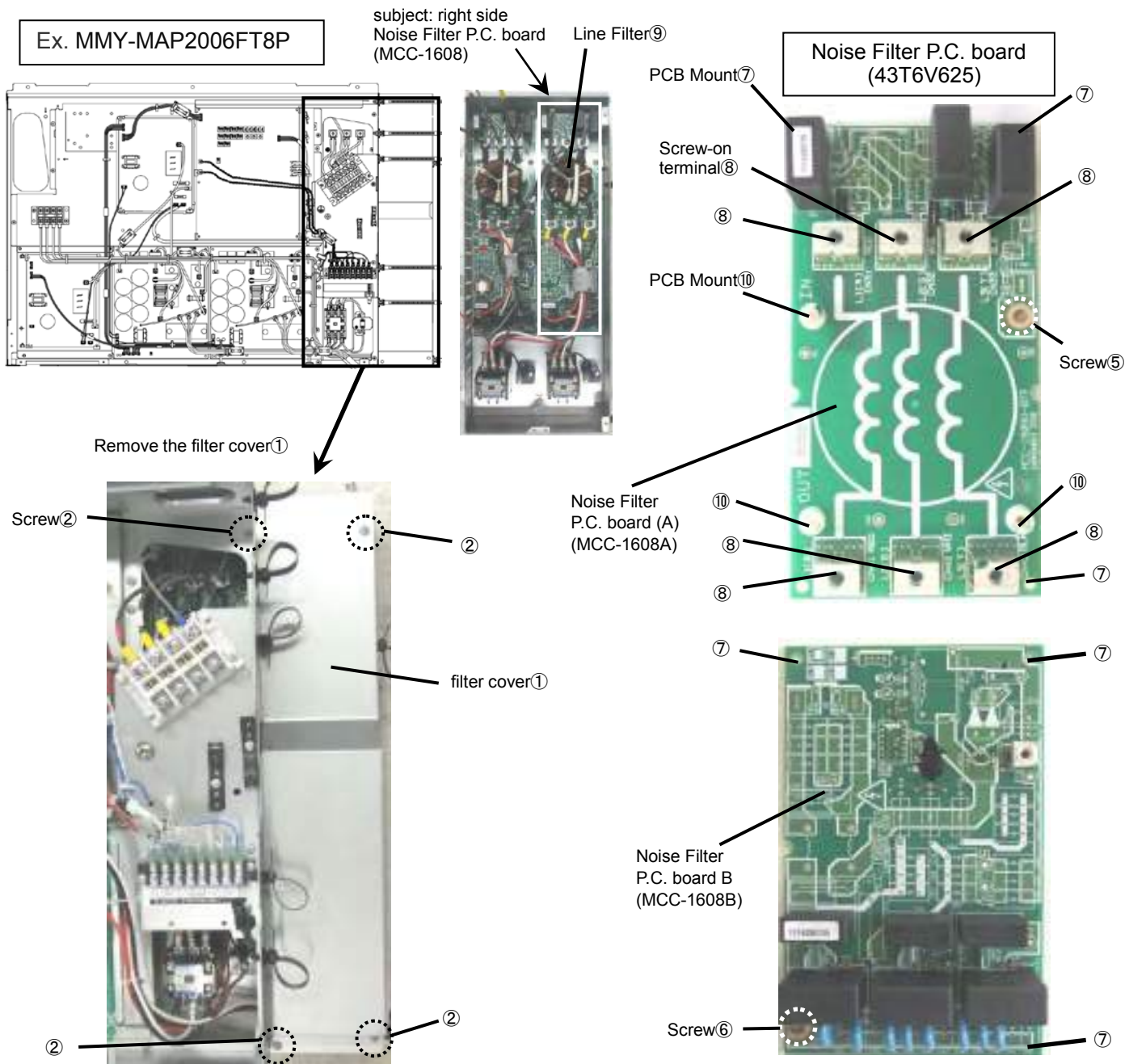

- (3) Disconnect all the connectors and Faston terminals used to connect wiring to the noise filter P.C. board.
• The line filter ⑨ and its leads, both connected to the screw-on terminals ⑧ of the noise filter P.C. board (A) will be removed in step 6.
• Disconnect all the connectors and Faston terminals.
- (4) Remove the earthing screws ⑤, ⑥ and the three PCB mount ⑩.
• The removed earthing screws ⑤, ⑥ and the PCB mount ⑩ will be reused during the installation of the service P.C. board, so keep them in a safe place.

- (5) Remove the noise filter P.C. board assembly by unlocking the four PCB mounts used to secure the P.C. board ⑦.
- (6) Remove the line filter ⑨ and its leads, both connected to the screw-on terminals ⑧ of the just-removed noise filter P.C. board (A), and reinstall them on the service P.C. board (A) by firmly connecting them to the screw-on terminals ⑧ in the same manner as before.
- (7) Install the service P.C. boards (A) and (B) in the outdoor unit controller.
(Make sure that they are firmly secured to the PCB mounts ⑦ and ⑩.)

Line Filter installation:

Screw the line filter and the connecting wires together to the terminals as right figure.
The torque of 6 screws of the line filter is "1.84ft·lbs (2.5Nm)".

Please check that the screws connecting the line filter are not loose. If the screw is loose, the screw will generate heats, and cause the line filter to breakdown.

Do not use an electric driver or an air driver, as this can cause damage to the line filter.

Connect the wires according to the wiring diagram.

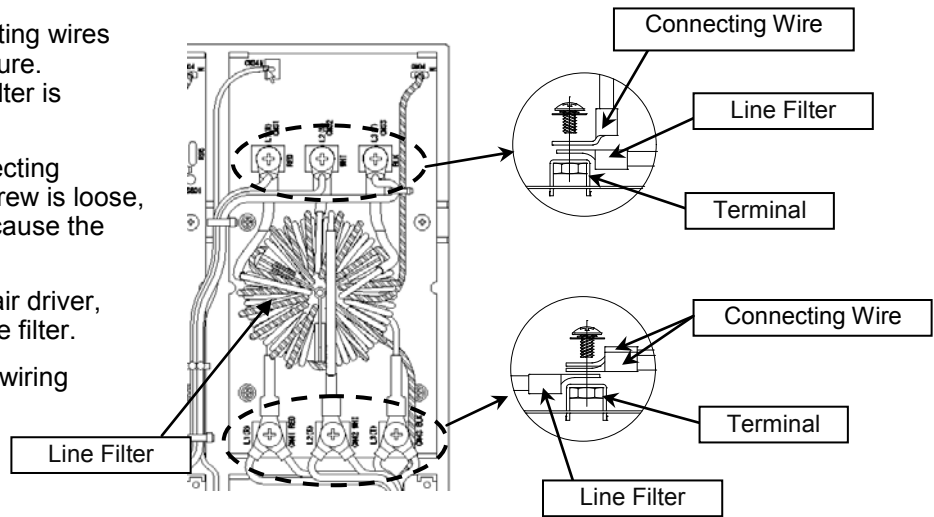

- (8) Securely connect the service P.C. boards to the chassis using the earthing screws ⑤, ⑥ removed in step (4).
If either of the screws is loose, it will pose a risk of device failure by degrading noise control, so take care while engaging in the work. Nevertheless, do not use an electric or pneumatic screwdriver under any circumstances as it may lead to component damage.
- (9) Connect the wiring using the connectors and Fastons removed in step (3).
Make sure that the connectors and Fastons are connected correctly and securely.
- (10) If any component on the P.C. board becomes crooked during replacement, straighten it without touching any other component.
- (11) Mount the filter cover ① and firmly secure it using the screws ②.
- (12) Put the cover on, turn on the power, and check operation.



Close-up view of screw-on terminals ⑧

Screw tightening torque (N·m)

Screw diameter	Torque (N·m)
M6	2.5±0.1
M4	1.2±0.1
M3	0.5±0.1



close-up view of terminal block sub-assembly and filter cover

14 MULTI PORT FS UNIT PARTS REPLACEMENT

WARNING

•Wear a pair of gloves.

Otherwise, you will risk an injury involving a replacement part or some other object.

•Stop the power supply of the air conditioner and turn off switch of the power supply breaker.

1. Electric parts cover

1 Detachment

- 1) Remove the screws of under side. ($\phi 4 \times 8$, 2 pcs)
- 2) Loosen fixing screws of upper side. ($\phi 4 \times 8$, 2 pcs)
- 3) Pull the cover downward and then remove the cover.

2 Attachment

- 1) Hook the electrical component cover on the screw on the upper side. (2 places)
- 2) Slide up the electrical component cover and fit it in.
- 3) Fit the screws of under side. ($\phi 4 \times 8$, 2 pcs)
- 4) Tighten the screws of upper side. ($\phi 4 \times 8$, 2 pcs)



Hook to the screw



Cover

Screws



2. P.C.board

1 Detachment

- 1) Perform work of procedure 1-1 Detachment. (Electric parts cover)
- 2) Remove connectors which are connected from the control P.C.board to the other parts.

CN67 :	Power supply wires	Black
CN309 :	Power supply wires	Yellow
CN710 :	SVS, SVSS, SSVD, SVD	White
CN720 :	PMV	White
CN101 :	TCS sensor	White
CN400 :	Communication wire	Terminal block 2P
CN22 :	Earth wire	Faston tab

- 3) Unlock the locks of the card edge spacer (4 positions) and then remove the control P.C.board.

Card edge spacer



2 Attachment

- 1) Fix the control P.C.board to the card edge spacers. (4 positions)
- 2) Connect the connectors disconnected in item 1-2) as before.

For connectors, check there is no missing or contact failure.

- 3) Attach the Electric parts cover. (Refer to 1. of 2 Attachment)

3. TERMINAL-PW (TB03)

1 Detachment

- 1) Perform work of procedure 1. of 1 Detachment . (Electric parts cover)
- 2) Remove the wires from the TERMINAL-PW (TB03).
- 3) Take off screws fixing the TERMINAL-PW (TB03). ($\phi 4 \times 14$, 2 pcs)

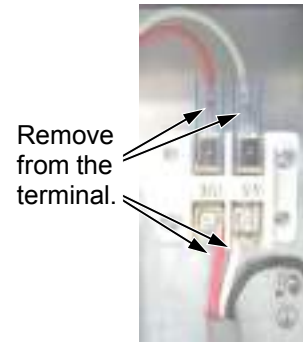

2 Attachment

- 1) Fix the terminal assembly as before.
- 2) Fit the fixing screws ($\phi 4 \times 14$, 2 pcs).
- 3) Connect the wires disconnected as before.
- 4) Attach the Electric parts cover. (Refer to 1. of 2 Attachment)

4. TERMINAL-2P (TB01, TB02)

1 Detachment

- 1) Perform work of procedure 1. of 1 Detachment . (Electric parts cover)
- 2) Remove the wires from the TERMINAL (TB01 and TB02).
- 3) Take off the screws fixing the TERMINAL (TB01 and TB02). ($\phi 4 \times 14$, 1pc)



- 1) Fix the terminal assembly as before.

Fit the cylindrical protrusion of the terminal block (TB01 and TB02) into the hole of the sheet metal of the electrical box.

- 2) Fit the screws ($\phi 4 \times 14$, 1 pc)
- 3) Connect the wires disconnected as before.

For the leads of the coil (3 pcs) that has the faston terminal of the straight type on the edge, connect each of them to any of the tab on the right side of the TERMINAL (TB02)(4 places). (Refer to fig.A) For the leads of the coil (6 pcs) that has the faston terminal of the flag type on the edge (one side) and the lead (1 pc) that has the faston terminal of the flag type on the both ends, connect them to the TERMINAL (TB01). (Refer to fig.A) For the connection direction to the TERMINAL (TB01) for the lead that has the faston terminal of the flag type , refer to the figure B.

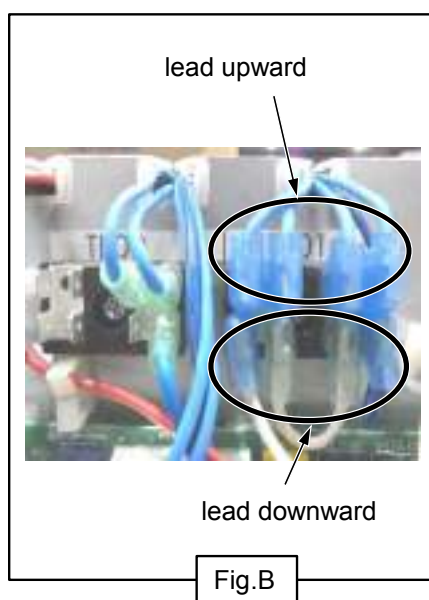
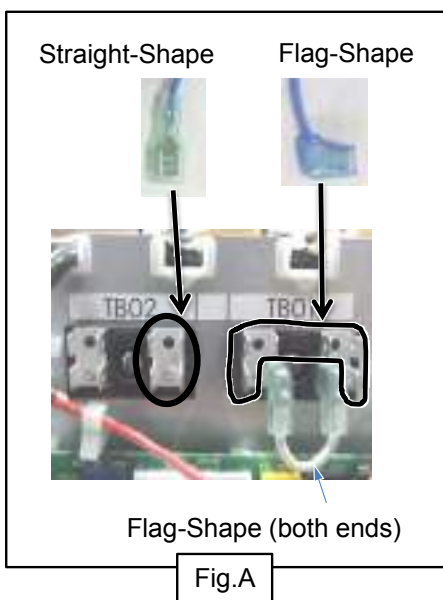

- 4) Attach the Electric parts cover. (Refer to 1.-2)

5. Top plate

1 Detachment

- 1) Take off the fixing screws ($\phi 4 \times 8$, 6 pcs)
- 2) Remove the top plate.

Position of the screw holes
(Top plate)

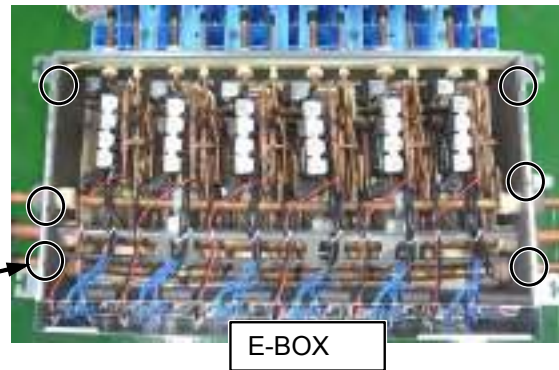

2 Attachment

- 1) Fix the Top plate as before.

Fit the non-thermal insulation material side to the E-Box side.

- 2) Fit the screws. ($\phi 4 \times 8$, 6 pcs.)

Non-heat
insulation

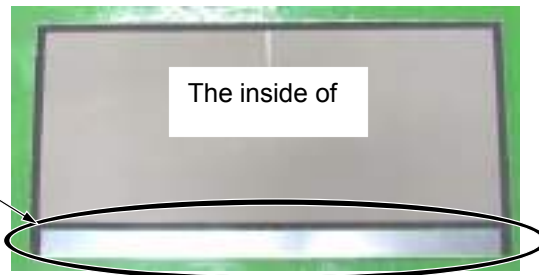

6. Coil of 2WAY-VALVE (SVS, SVSS, SVDD, SVD)

1 Detachment

- 1) Perform work of procedure 1. -1) (Electric parts cover) and 5. -1) (top plate).
- 2) Cut the binding band (1 pc) for bundling the wires of the coil (SVS, SVSS, SVDD, SVD).

Binding band



- 3) Take off the fixing screws, remove the Coil connection plate and then remove the coil.

Fixing screw size
SVS, SVSS, SVDD : M4 x 6 (4 pcs)
SVD : M4 x 8 (1 pc)

- 4) Remove the wires from the terminal (TB01, TB02) and the P.C.board (CN710).

Coil connection plate Heat sink (SVSS, SVD) Screw (M4 x 8, 1pc)

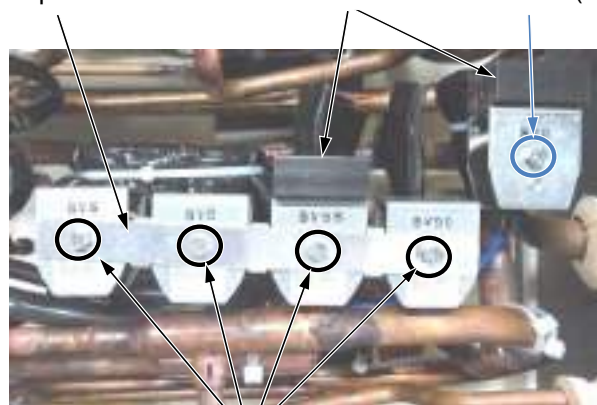

Screws (M4x6, 4pcs)

Heat sink

1 Detachment

- 1) Take off the fixing screws. (M4 x 8, 2 pcs)
- 2) Remove the heat sink from the coil. (SVSS or SVD)

2 Attachment

- 1) Fix the heat sink as before.

Fix the heatsink to the direction indicated in the figure.

- 2) Fit the screws of the heatsink (M4 x 8, 2 pcs) at a torque of $1.47 \pm 0.1 \text{ N}\cdot\text{m}$.

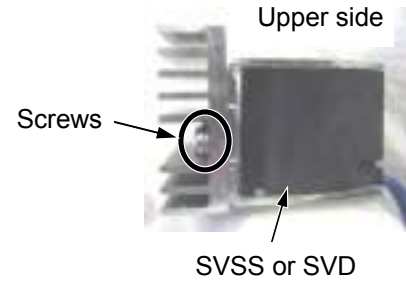

2 Attachment

- 1) Fix the coil and the Coil connection plate as before and fit the screws.

Attach the coil to the position indicated in the coil attachment nameplate. Be careful about the attachment directions of the coil and Coil connection plate.

Fixing screw size
 SVS, SVSS, SVDD : M4 x 6 (4 pcs)
 SVD : M4 x 8 (1 pc)

Be careful of using the different screw.
 Control tightening torque of the coil with $2.0 \pm 0.1 \text{ N}\cdot\text{m}$.

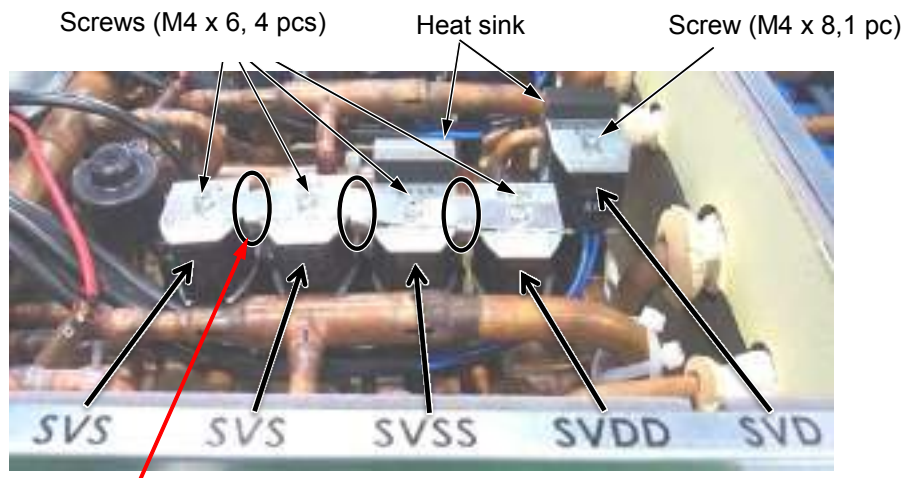

For the coil connecting plate, attach the flange downward.

- 3) Connect the wires disconnected as before.
- 4) Bind the the wires of the coil (SVS, SVSS, SVDD, SVD) to the reinforcement plate by binding band (field supply) (1 pc).

Wire the lead through the lower side than the coil so that the edge of the coil do not damage the lead

Binding band
(field supply)



Wiring position

- 5) Attach the Electric parts cover and the Top plate. (Refer to 1. -2) and 5. -2))

7. Coil-PMV, TCS-sensor

1 Detachment

- 1) Perform work of procedure 1. -1) (Electric parts cover) and 5. -1) (Top plate).
- 2) Cut the binding band (1 pc) which fix the Clamp filter to the wires of the Coil-PMV and the TCS-Sensor.
- 3) Remove the Clamp filter from the wires of the Coil-PMV and TCS-Sensor.
- 4) Remove the wires of Coil-PMV from the Wire-clamp.
- 5) Remove each wire which is connected from the control P.C.board to other parts.

CN720	PMV	White
CN101	TCS Sensor	White

- 6) Cut the binding band (1 pc) of gathering wires of the Coil-PMV and the TCS-Sensor and the wires remove from reinforcement plate.

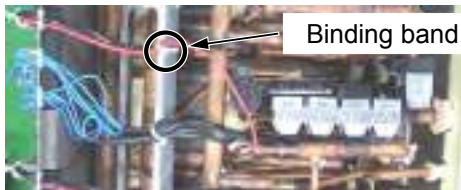

- 7) Remove the Coil-PMV or the TCS-Sensor.

2 Attachment

- 1) Fix Coil-PMV or TCS-Sensor assembly as before.

The claw of Coil-PMV should be fitted to the pipe. Be careful about deformation of the pipe of connecting PMV. The TCS-sensor should be inserted deeply into the sensor holder.

- 2) Connect the wires disconnected as before.

- 3) Fix the wire of the PMV-Coil by the Wire-Clamp as before.
- 4) Fix the Clamp filter by the binding band (field supply) (1 pc) to the wires of the Coil-PMV and the TCS-Sensor.
- 5) Fix the wires of Coil-PMV and TCS-Sensor by the binding band (field supply) (1 pc) to the reinforcement plate.



Binding band (field supply)

- 6) Attach the Electric parts cover and the Top plate. (Refer to 1. -2) and 5. -2))

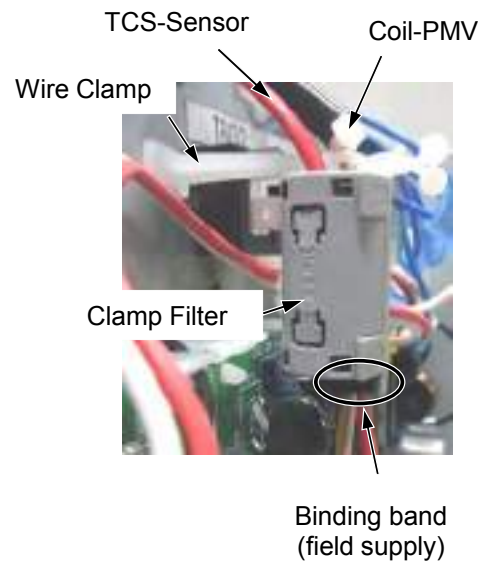
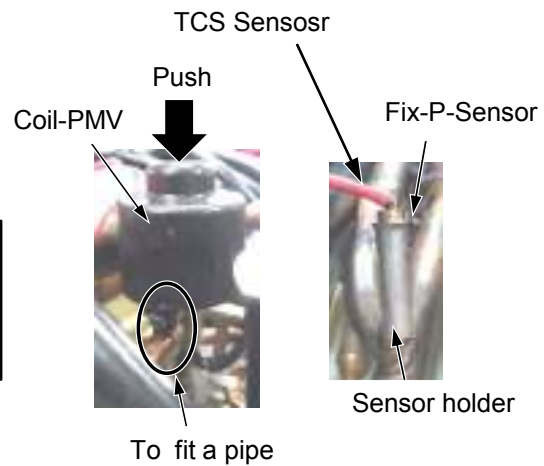
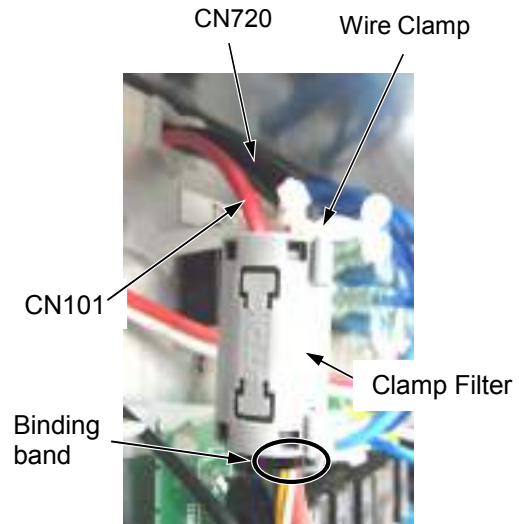

8. Drain hose

1 Detachment

- 1) Drain the drain water accumulated in the Drain pan.
- 2) Remove the Drain hose while picking the claws of the hose band.

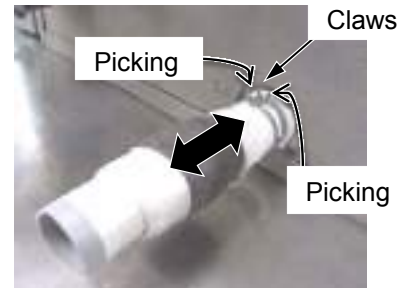

2 Attachment

- 1) Pinch the claw of the hose band and make it loosen, then insert the drain hose.

Insert the hose surely to the end of Drain pan that the joints does not have water leak

9. Bottom plate, Drain pan

1 Detachment

- 1) Perform work of procedure 8. -1). (Drain hose)
- 2) Take off the fixing screws ($\phi 4 \times 8,4$ pcs)
- 3) Remove the Bottom plate and Drain pan together.
- 4) Remove the Drain pan from the Bottom plate while tilting it.

Be careful, the Drain pan should not be damaged by the edge of Bottom plate.

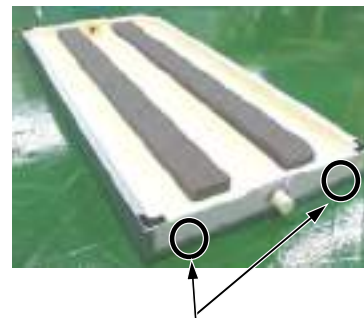

Position of the screw holes (both side of the Bottom plate)

2 Attachment

- 1) Fit the Drain pan to the Bottom plate while tilting it as before.

Be careful, the Drain pan should not be damaged by the edge of Bottom plate.

- 2) Fit the Bottom plate and Drain pan together to the cabinet.

The flange of the bottom plate is located outside of sheet metal of the cabinet.

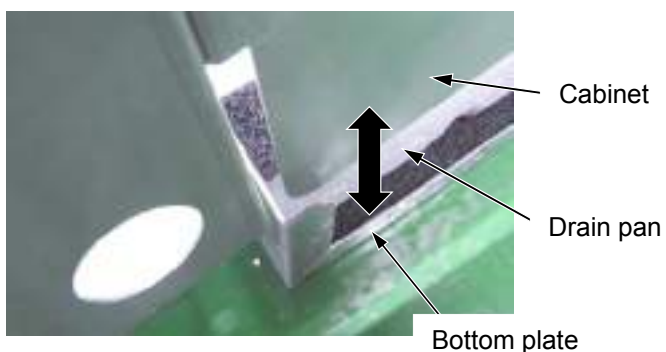
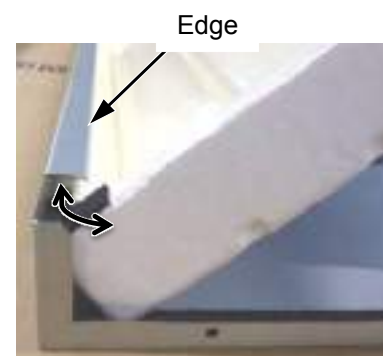

- 3) Fit the fixing screws. ($\phi 4 \times 8, 4$ pcs)
- 4) Attach the Drain hose. (Refer to 8. -2))

15 SINGLE PORT FS UNIT (LONG PIPING MODEL) PART REPLACEMENT METHOD

WARNING

- Wear a pair of gloves.
- Otherwise, you will risk an injury involving a replacement part or some other object.
- Stop the power supply of the air conditioner and turn off switch of the power supply breaker.

1. Electric parts cover

1 Detachment

- 1) Loosen fixing screws. ($\phi 4 \times 8$, 2 pcs)
- 2) Pull the cover downward and then remove the cover.

2 Attachment

- 1) Hook the electric parts cover on the screw. (2 places)
- 2) Slide up the electric parts cover and fit it in.
- 3) Tighten the screws. ($\phi 4 \times 8$, 2 pcs)

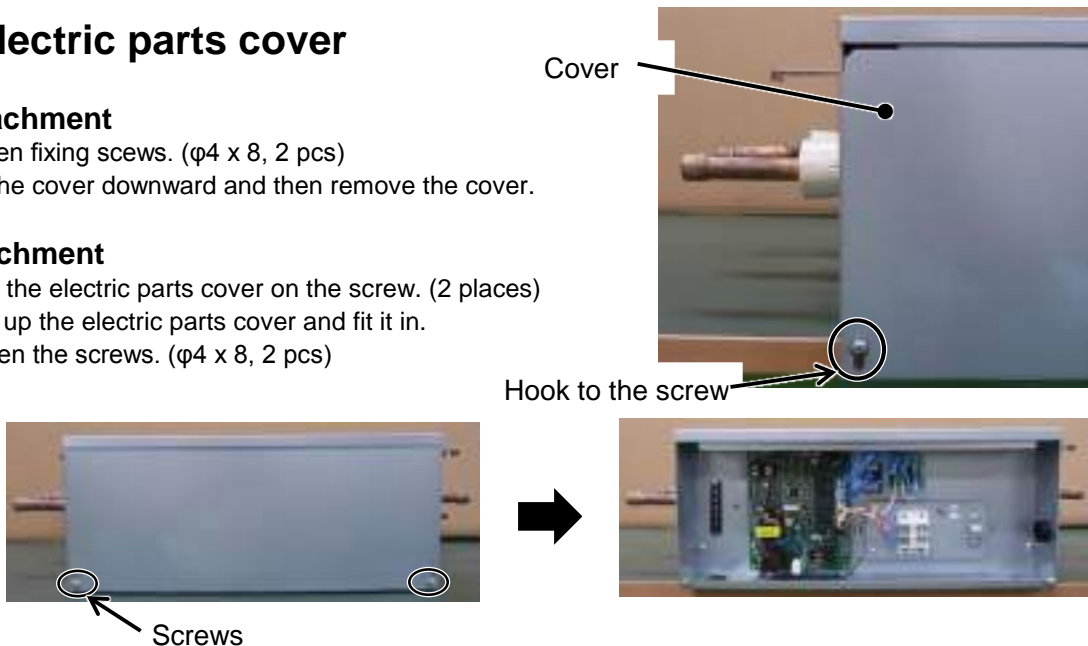

2. P.C.board

1 Detachment

- 1) Perform work of procedure 1-1 Detachment. (Electric parts cover)
- 2) Remove connectors which are connected from the control P.C.board to the other parts.

CN67 :	Power supply wires	Black
CN710 :	SVS, SVSS, SVDD, SVD	White
CN720 :	PMV	White
CN101 :	TCS sensor	White
CN400 :	Communication wire	Terminal block 2P
CN22 :	Earth wire	Faston tab

- 3) Unlock the locks of the card edge spacer (4 positions) and then remove the control P.C.board.



2 Attachment

- 1) Fix the control P.C.board to the card edge spacers. (4 positions)
- 2) Connect the connectors disconnected in item 1-2) as before.

For connectors, check there is no missing or contact failure.

- 3) Attach the Electric parts cover. (Refer to 1. of 2 Attachment)

3. TERMINAL-PW (TB03)

1 Detachment

- 1) Perform work of procedure 1. of 1 Detachment . (Electric parts cover)
- 2) Remove the wires from the TERMINAL-PW (TB03).
- 3) Take off screws fixing the TERMINAL-PW (TB03). ($\phi 4 \times 14$, 2 pcs)

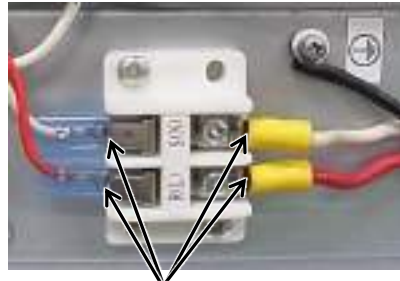

Remove from the terminal.

2 Attachment

- 1) Fix the terminal assembly as before.
- 2) Fit the fixing screws ($\phi 4 \times 14$, 2 pcs).
- 3) Connect the wires disconnected as before.
- 4) Attach the Electric parts cover. (Refer to 1. of 2 Attachment)

4. TERMINAL-2P (TB01, TB02)

1 Detachment

- 1) Perform work of procedure 1. of 1 Detachment . (Electric parts cover)
- 2) Remove the wires from the TERMINAL (TB01 and TB02).
- 3) Take off the screws fixing the TERMINAL (TB01 and TB02). ($\phi 4 \times 14$, 1pc)



Fit in the hole

2 Attachment

- 1) Fix the terminal assembly as before.

Fit the cylindrical protrusion of the terminal block (TB01 and TB02) into the hole of the sheet metal of the electrical box.

- 2) Fit the screws ($\phi 4 \times 14$, 1 pc)
- 3) Connect the wires disconnected as before.

[RBM-Y1124FE/FE2]

(Refer to fig.A) For the leads of the coil (5pcs) that has the faston terminal of the flag type on the edge (one side) and the lead (1pc) that has the faston terminal of the flag type on the both ends, connect them to the TERMINAL (TB01). (Refer to fig.A) For the connection direction to the TERMINAL (TB01) for the lead that has the faston terminal of the flag type , refer to the figure A.

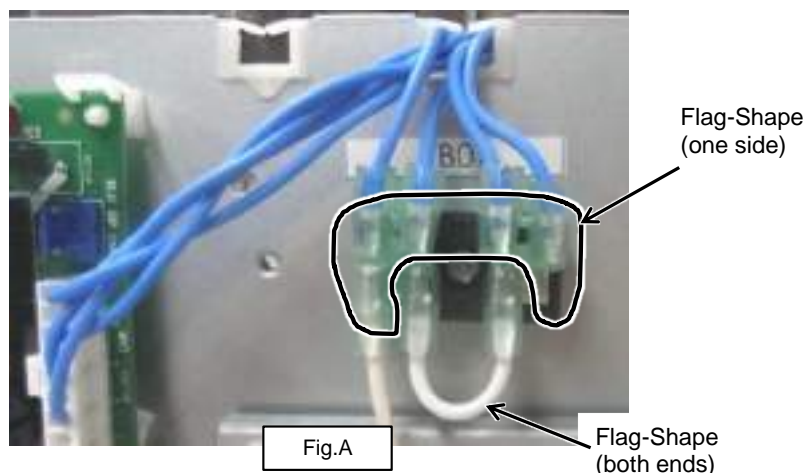

[RBM-Y1804FE/FE2]

For the leads of the coil (3pcs) that has the faston terminal of the straight type on the edge(Sleeve : colorless), connect each of them to any of the tab on the upper side of the TERMINAL (TB02)(4 places).
 For the leads of the coil (2pcs) that has the faston terminal of the straight type on the edge(Sleeve : green), connect each of them to any of the tab on the under side of the TERMINAL (TB02)(4 places).
 (Refer to fig.B) For the leads of the coil (6pcs) that has the faston terminal of the flag type on the edge (one side) and the lead (1pc) that has the faston terminal of the flag type on the both ends, connect them to the TERMINAL (TB01). (Refer to fig.B) For the connection direction to the TERMINAL (TB01) for the lead that has the faston terminal of the flag type , refer to the figure B.

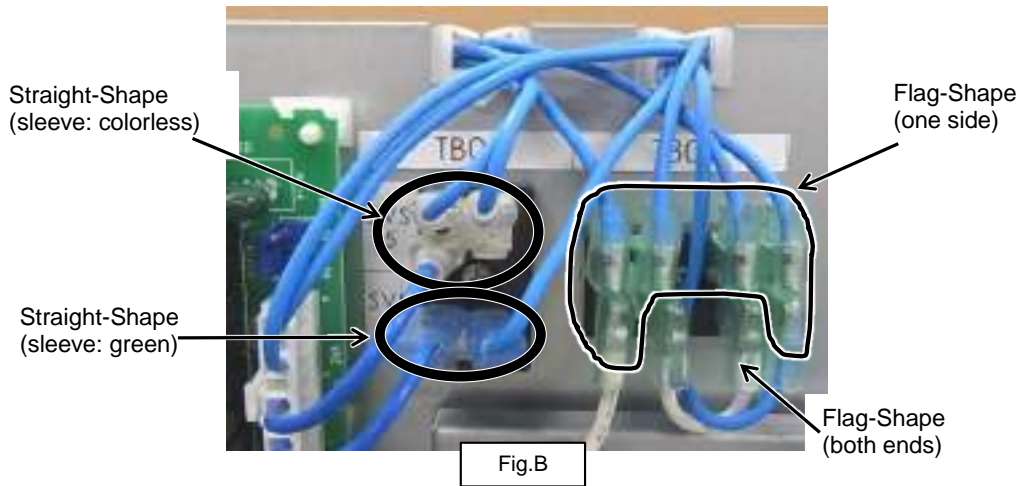

[RBM-Y2804FE/FE2]

For the leads of the coil (4pcs) that has the faston terminal of the straight type on the edge(sleeve : colorless), connect each of them to any of the tab on the upper side of the TERMINAL (TB02)(4 places).
 For the leads of the coil (3pcs) that has the faston terminal of the straight type on the edge(sleeve : green), connect each of them to any of the tab on the under side of the TERMINAL (TB02)(4 places).
 (Refer to fig.C) For the leads of the coil (6pcs) that has the faston terminal of the flag type on the edge (one side) and the lead (2pcs) that has the faston terminal of the flag type on the both ends, connect them to the TERMINAL (TB01-1 and TB01-2). (Refer to fig.C) For the connection direction to the TERMINAL (TB01-1 and TB01-2) for the lead that has the faston terminal of the flag type , refer to the figure C.

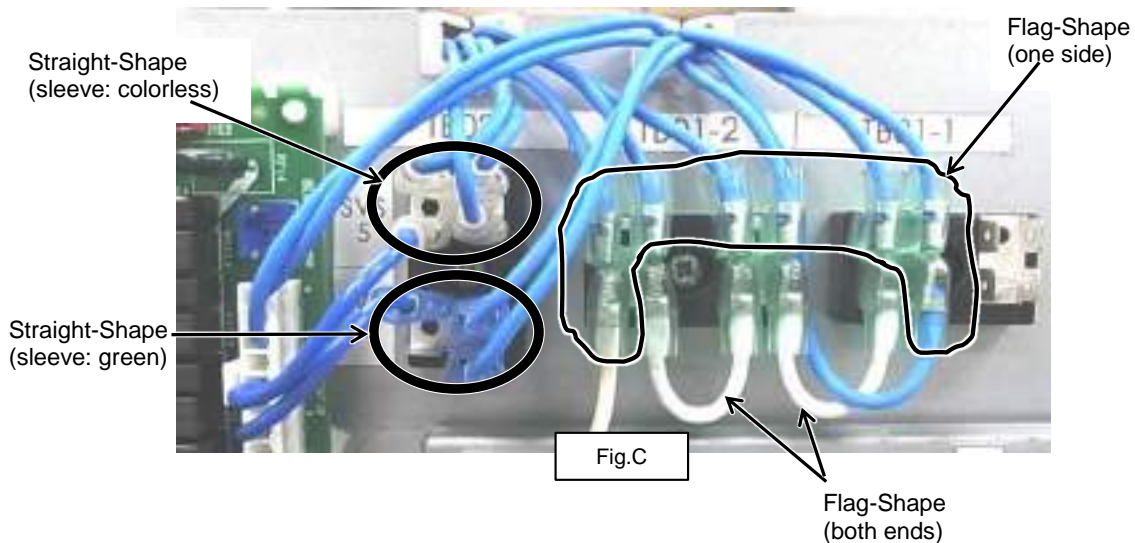

4) Attach the Electric parts cover. (Refer to 1.-2)

5. Top plate

1 Detachment

- 1) Take off the fixing screws ($\varnothing 4 \times 8$, 3 pcs)
- 2) Remove the top plate.



2 Attachment

- 1) Fix the Top plate as before.
- 2) Fit the screws. ($\varnothing 4 \times 8$, 3 pcs.)

6. Coil of 2WAY-VALVE (SVS, SVSS, SVDD, SVD)

1 Detachment

- 1) Perform work of procedure 1. -1) (Electric parts cover) and 5. -1) (top plate).
- 2) Remove lead wires of coils(SVS,SVSS, SVDD, SVD) from wire clamp.
- 3) Remove fixing screws with the Coil connection plate and then remove the coil.

Fixing screw size
SVS ,SVSS ,SVDD,SVD : M4 x 6 (1 ea.)

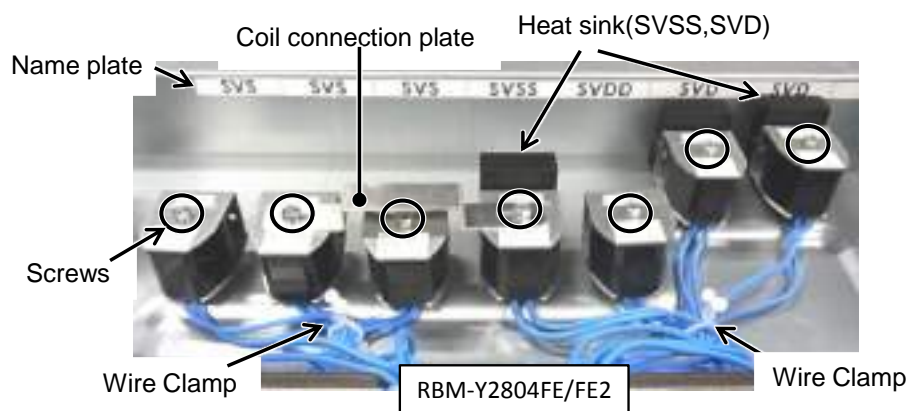
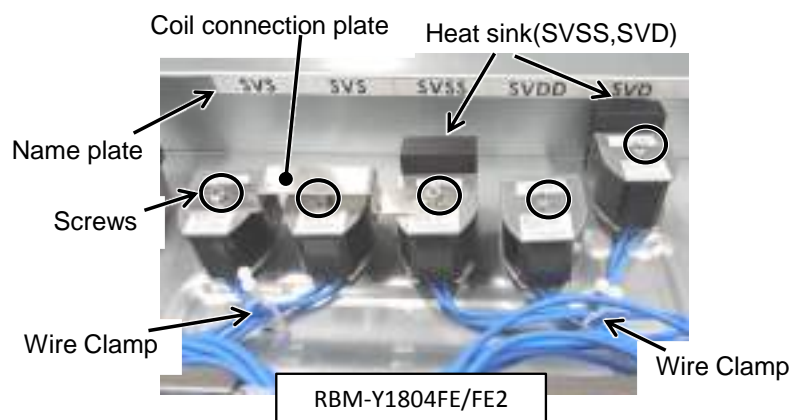
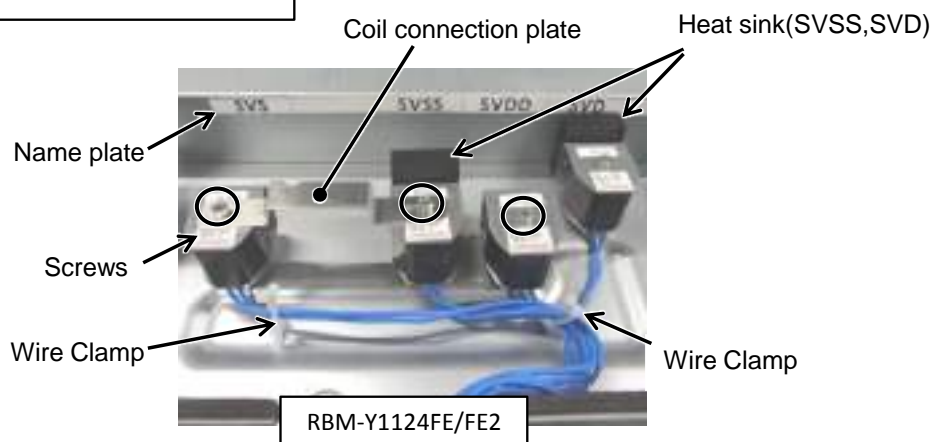

- 4) Remove the wires from the terminal (TB01,TB02) and the P.C.board (CN710).

Heat sink

1 Detachment

- 1) Take off the fixing screws. (M4 x 8, 2 pcs)
- 2) Remove the heat sink from the coil. (SVSS or SVD)

2 Attachment

- 1) Fix the heat sink as before.

Fix the heatsink to the direction indicated in the figure.

- 2) Fit the screws of the heatsink (M4 x 8, 2 pcs) at a torque of $1.47 \pm 0.1 \text{ N}\cdot\text{m}$.

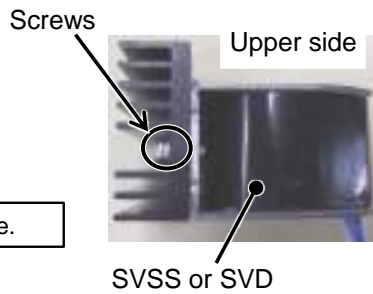

2 Attachment

- 1) Fix the coil and the Coil connection plate as before and fit the screws.

Attach the coil to the position indicated in the coil attachment nameplate. Be careful about the attachment directions of the coil .

Fixing screw size

SVS ,SVSS ,SVDD,SVD : M4 x 6 (each 1 pc)

Control tightening torque of the coil with $2.0 \pm 0.1 \text{ N}\cdot\text{m}$.

- 2) Connect the wires disconnected as before.
- 3) Fix wires of coils (SVS, SVSS, SVDD, SVD) by the wire clamp.

Wire the lead through the lower side than the coil so that the edge of the coil do not damage the lead.

- 4) Attach the Electric parts cover and the Top plate. (Refer to 1. -2) and 5. -2))

7. Coil-PMV

1 Detachment

- 1) Perform work of procedure 1. -1) (Electric parts cover) and 5. -1) (Top plate).
- 2) Cut the binding band (1 pc) which fix the Clamp filter to the wires of the Coil-PMV and the TCS-Sensor.
- 3) Remove the Clamp filter from the wires of the Coil-PMV and TCS-Sensor.
- 4) Remove the wires of Coil-PMV from the Wire-clamp.
- 5) Remove each wire which is connected from the control P.C.board to other parts.

CN720 PMV White

- 6) Cut the binding band (1 pc) of gathering wires of the Coil-PMV and the TCS-Sensor
- 7) Remove the Coil-PMV.

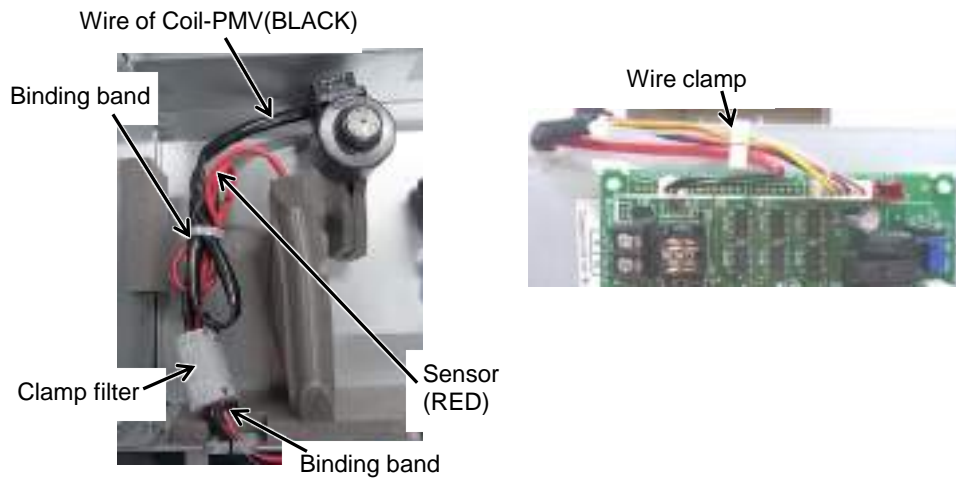

2 Attachment

- 1) Fix Coil-PMV assembly as before.

The claw of Coil-PMV should be fitted to the pipe.
Be careful about deformation of PMV pipe.

- 2) Connect the wires disconnected as before.
- 3) Fix the wire of the PMV-Coil by the Wire-Clamp as before.
- 4) Fix the Clamp filter by the binding band (field supply) (1 pc) to the wires of the Coil-PMV and the TCS-Sensor.
- 5) Fix wire of coil-PMV with wire of sensor by a binding band.
- 6) Attach the Electric parts cover and the Top plate. (Refer to 1. -2) and 5. -2))

8.TCS-sensor

1 Detachment

- 1) Perform work of procedure 1. -1) (Electric parts cover) and 5. -1) (Top plate).
- 2) Cut the binding band (1 pc) which fix the Clamp filter to the wires of the Coil-PMV and the TCS-Sensor.
- 3) Remove the Clamp filter from the wires of the Coil-PMV and TCS-Sensor.
- 4) Remove the wires of Coil-PMV from the Wire-clamp.
- 5) Remove each wire which is connected from the control P.C.board to other parts.

CN101	TCS Sensor	White
-------	------------	-------

- 6) Cut the binding band (1 pc) of gathering wires of the Coil-PMV and the TCS-Sensor
- 7) Remove heat-insulation covered sensor.
- 8) Remove the TCS-Sensor.

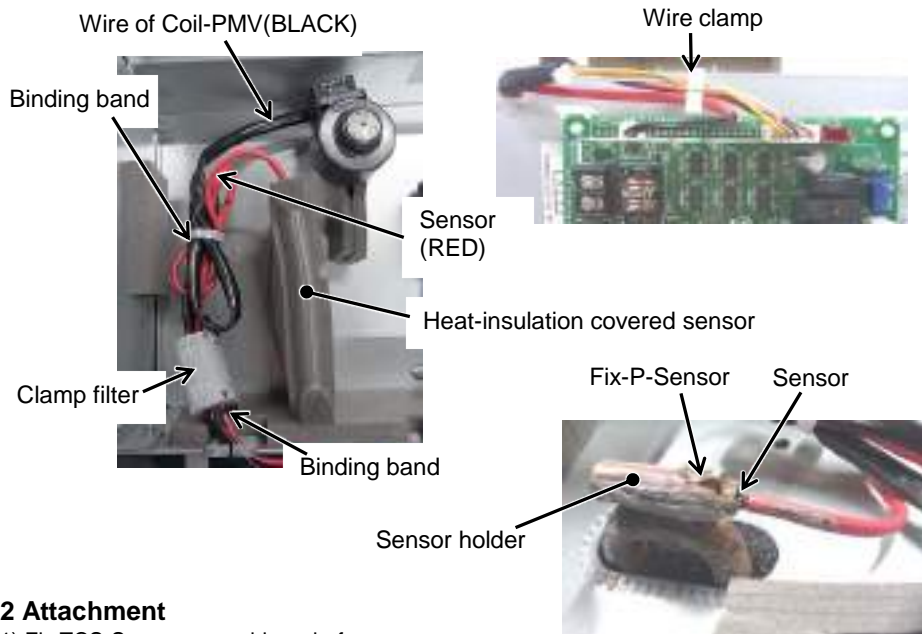

2 Attachment

- 1) Fix TCS-Sensor assembly as before.

The TCS-sensor should be inserted deeply into the sensor holder.
--

- 2) Connect the wires disconnected as before.
- 3) Fix the wire of the PMV-Coil by the Wire-Clamp as before.
- 4) Fix the Clamp filter by the binding band (field supply) (1 pc) to the wires of the Coil-PMV and the TCS-Sensor.
- 5) Fix wire of coil-PMV with wire of sensor by a binding band.
- 6) Attach new heat-insulation packed in sensor-service kit to sensor pipe. Push it certainly without gap.

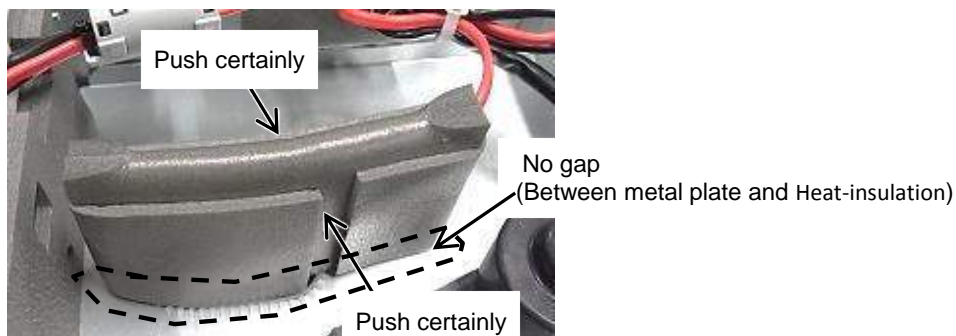

- 7) Attach the Electric parts cover and the Top plate. (Refer to 1. -2) and 5. -2))

9.BUSHING

1 Detachment

- 1) Perform work of procedure 1. of 1 Detachment . (Electric parts cover)
- 2) Push 2 hooks and remove Bush from Electrical parts box.



2 Attachment

- 1) Attach Bushing to Electrical parts box.

Push Bushing to hook to steel sheet certainly.

- 2) Attach the Electric parts cover. (Refer to 1. of 2 Attachment)

10.BUSHING

1 Detachment

- 1) Perform work of procedure 1. of 1 Detachment . (Electric parts cover)
- 2) Remove Bushing from Electrical box.



2 Attachment

- 1) Attach Bushing to Electrical parts box.

Push Bushing to set its groove to steel sheet certainly.

Groove → 

- 2) Attach the Electric parts cover. (Refer to 1. of 2 Attachment)

11.BODY-SERVE

Before the work, be sure to recover the refrigerant of outdoor unit into cylinders or another unit connected to the same system.

(Refer to the chapter on "refrigerant recovery methods to be used during compressor replacement")

1 Detachment

- 1) Remove connecting pipes from FS unit.
- 2) Remove FS unit from 3 hanging-bolts.
- 3) Perform work of procedure 6. of 1 Detachment . (Coil of 2way-valve(SVS,SVSS,SVDD,SVD))
- 4) Perform work of procedure 7. -1 (Coil-PMV) and 8. -1 (TCS-Sensor).
- 5) Remove screws of Electrical parts box. ($\phi 4 \times 8$, 4 pcs)
- 6) Remove screws of 3 Hanging brackets.($\phi 4 \times 8$, 2 pcs)

2 Attachment

- 1) Attach 3 hangers.($\phi 4 \times 8$, 2 pcs)
- 2) Attach Electrical parts box. ($\phi 4 \times 8$, 4 pcs)
- 3) Perform work of procedure 7. -2 (Coil-PMV) and 8. -2 (TCS-Sensor).
- 4) Attach heat-insulation packed in Body-service kit to the PMV pipe.

Heat-insulation is attached to cover the PMV pipe.

- 5) Perform work of procedure 6. of 2 Attachment . (Coil of 2way-valve(SVS,SVSS,SVDD,SVD))
- 6) Hang FS unit by fixing 3 hanging brackets with washers.

Put washers at up and down of hanging bracket.
Check that 4 sides are horizontal with a level gauge. (Horizontal degree: Within 5mm)

- 7) Connect and braze the connecting pipe.

**MMY-MAP0806FT8(J)P, MAP1006FT8(J)P,
 MMY-MAP0806FT7(J)P, MAP1006FT7(J)P,
 MMY-MAP0806FT8P-A, MAP1006FT8P-A**

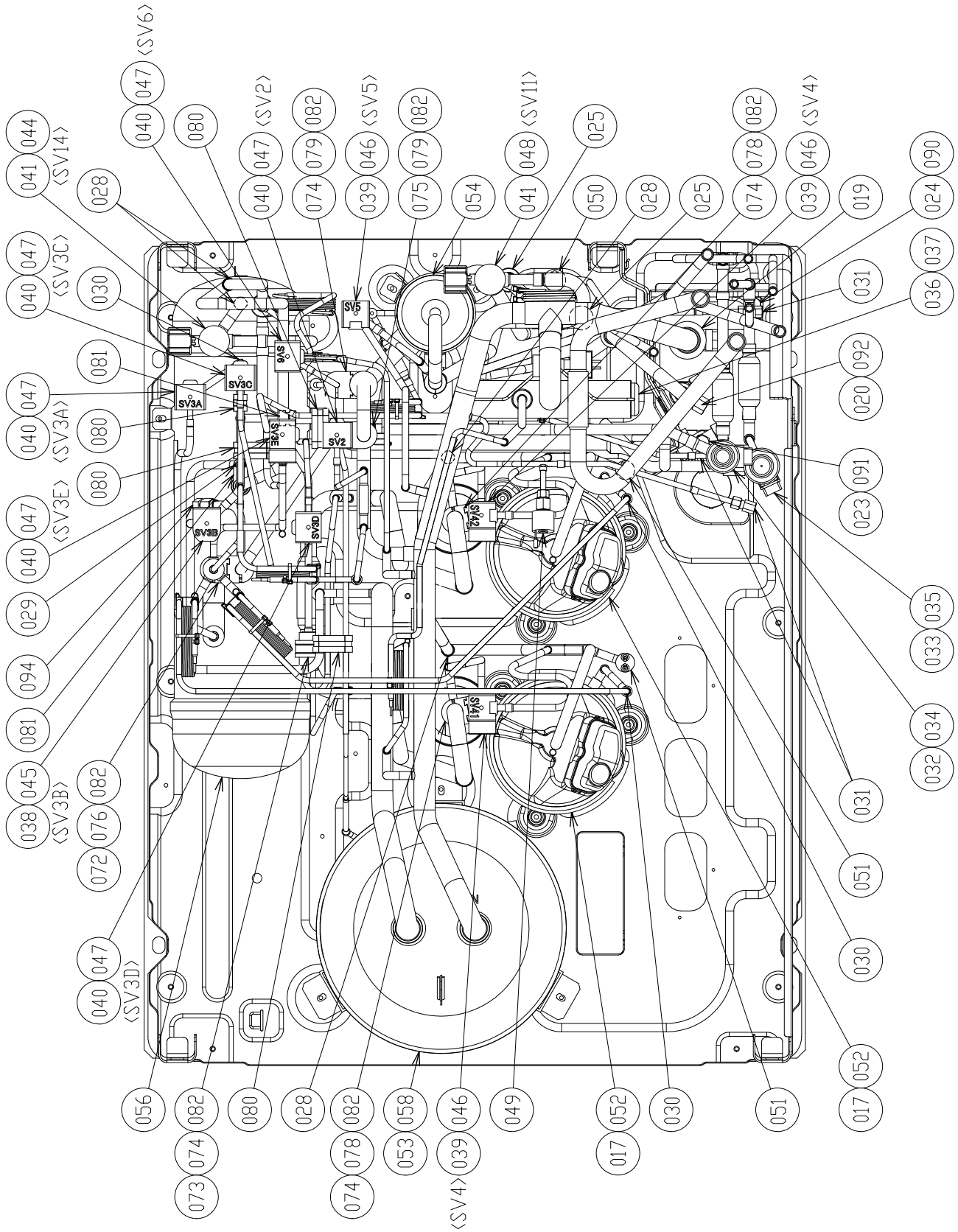

REFRIGERATION CIRCUIT DIAGRAM
MMY-MAP0806FT8(J)P-E, MAP1006FT8(J)P-E,
MMY-MAP0806FT8(J)P-TR, MAP1006FT8(J)P-TR,
MMY-MAP0806FT8(J)P-UK, MAP1006FT8(J)P-UK

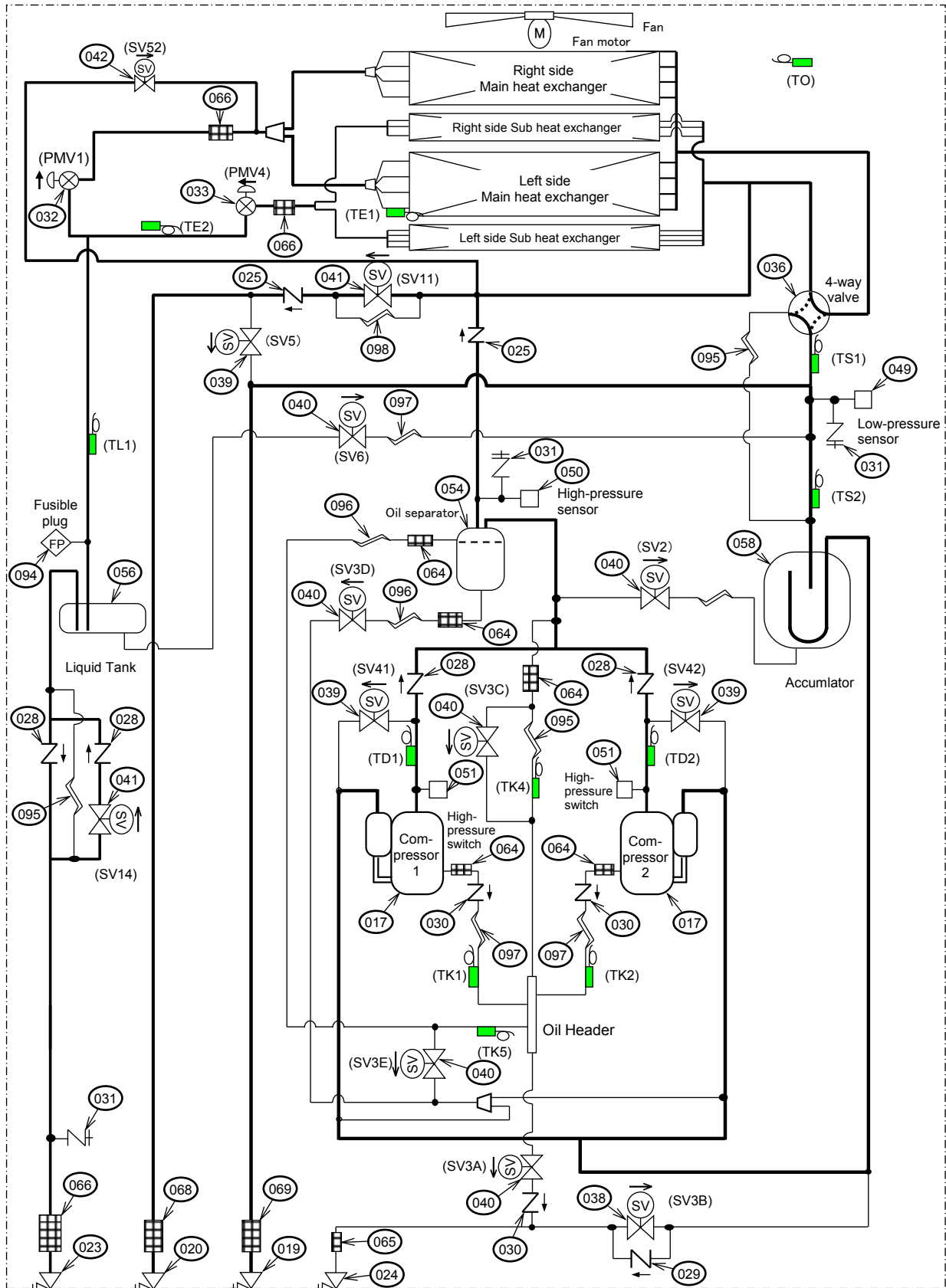

Liquid side Service valve Discharge-gas side Service valve Suction-gas side Service valve Balance pipe Service valve

Symbol						
Solenoid valve	Capillary tube	Check valve	Check joint	Strainer	Temperature sensor	Distributor

REFRIGERATION CIRCUIT DIAGRAM
MMY-MAP0806FT8(J)P, MAP1006FT8(J)P,
MMY-MAP0806FT7(J)P, MAP1006FT7(J)P,
MMY-MAP0806FT8P-A, MAP1006FT8P-A

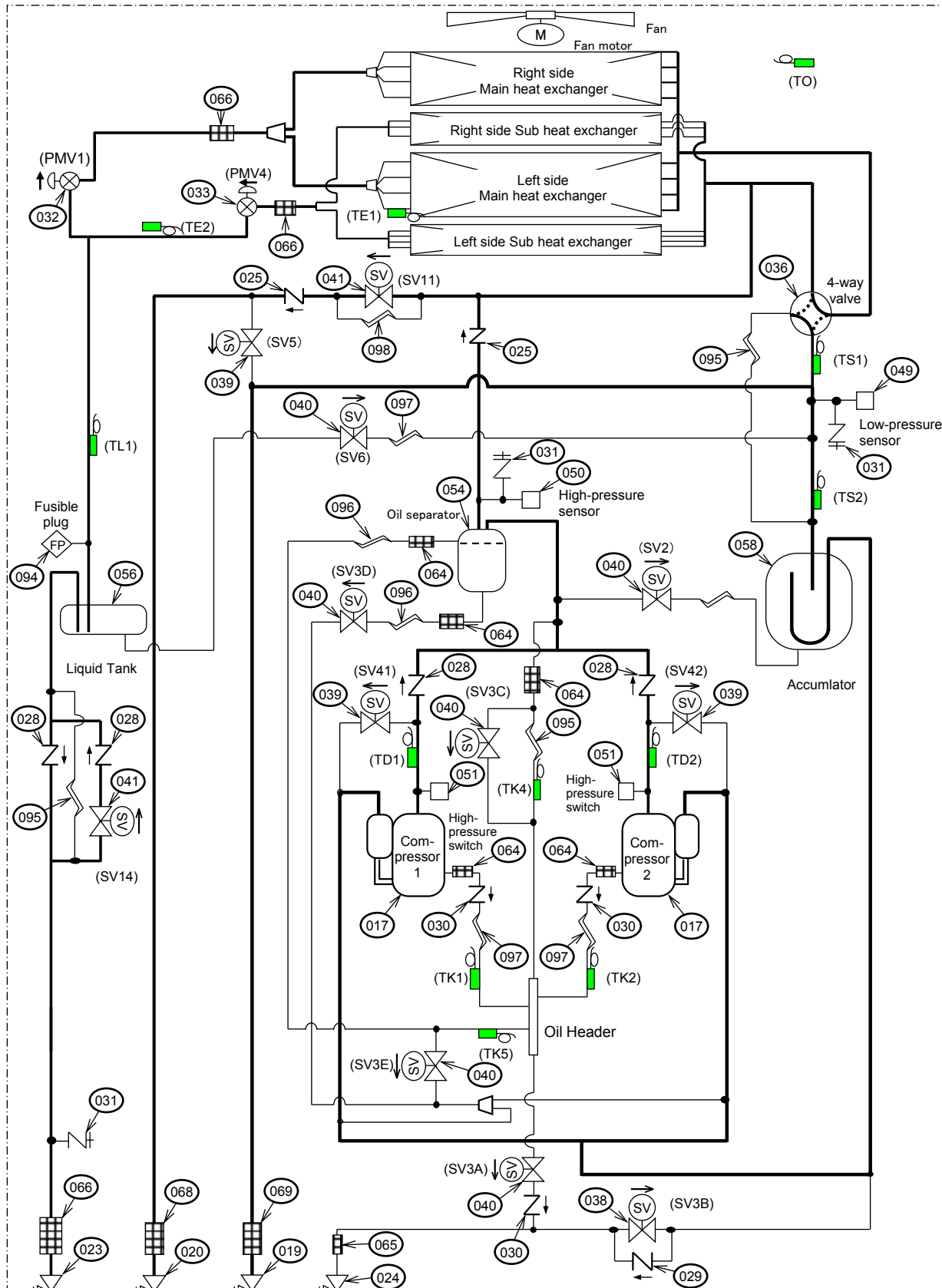

Symbol						
Solenoid valve	Capillary tube	Check valve	Check joint	Strainer	Temperature sensor	Distributor

**MMY-MAP1206FT8(J)P-E, MAP1406FT8(J)P-E,
 MMY-MAP1206FT8(J)P-TR, MAP1406FT8(J)P-TR,
 MMY-MAP1206FT8(J)P, MAP1406FT8(J)P,
 MMY-MAP1206FT7(J)P, MAP1406FT7(J)P,
 MMY-MAP1206FT8P-A, MAP1406FT8P-A,
 MMY-MAP1206FT8(J)P-UK, MAP1406FT8(J)P-UK**

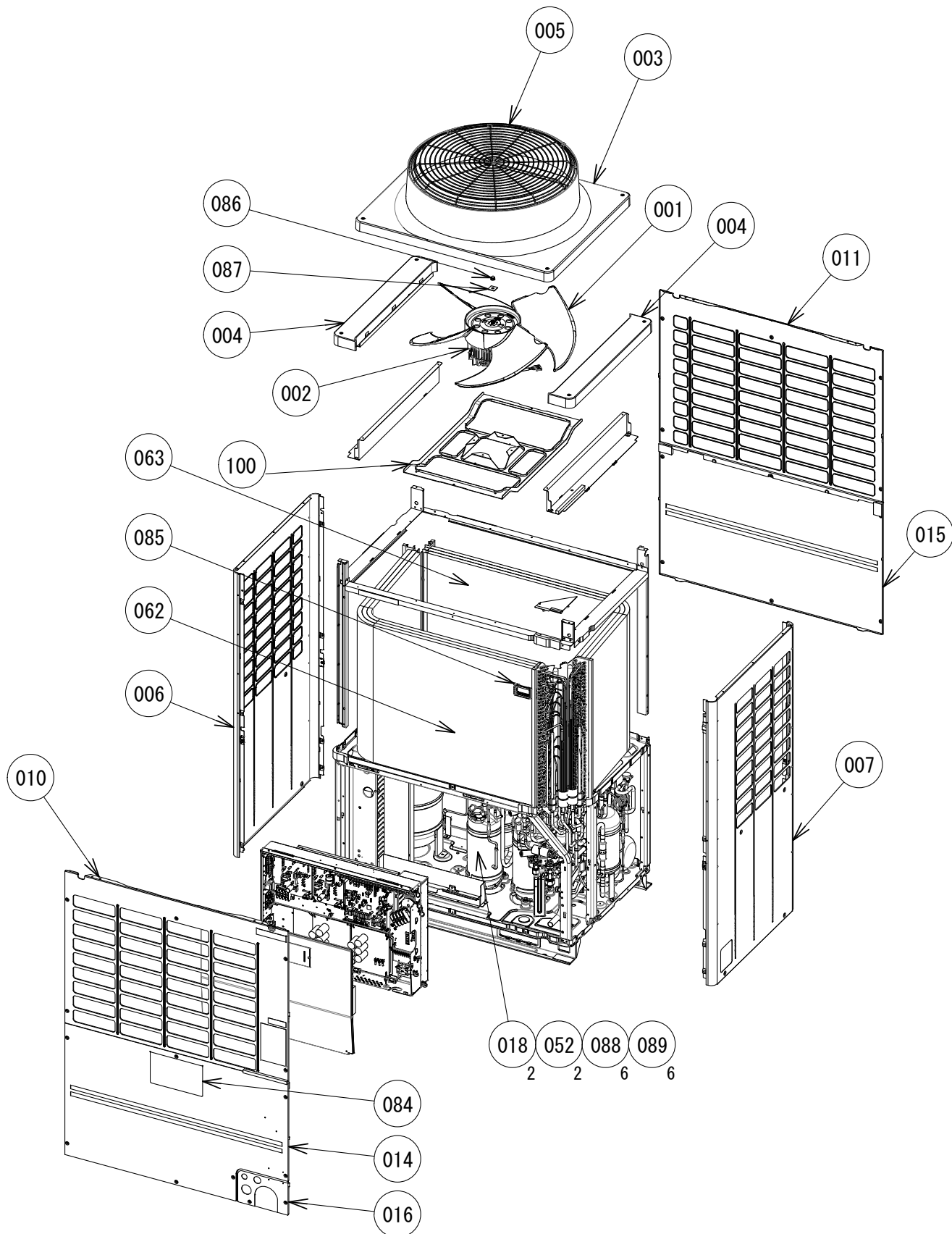

**MMY-MAP1206FT8(J)P-E, MAP1406FT8(J)P-E,
 MMY-MAP1206FT8(J)P-TR, MAP1406FT8(J)P-TR,
 MMY-MAP1206FT8(J)P-UK, MAP1406FT8(J)P-UK**

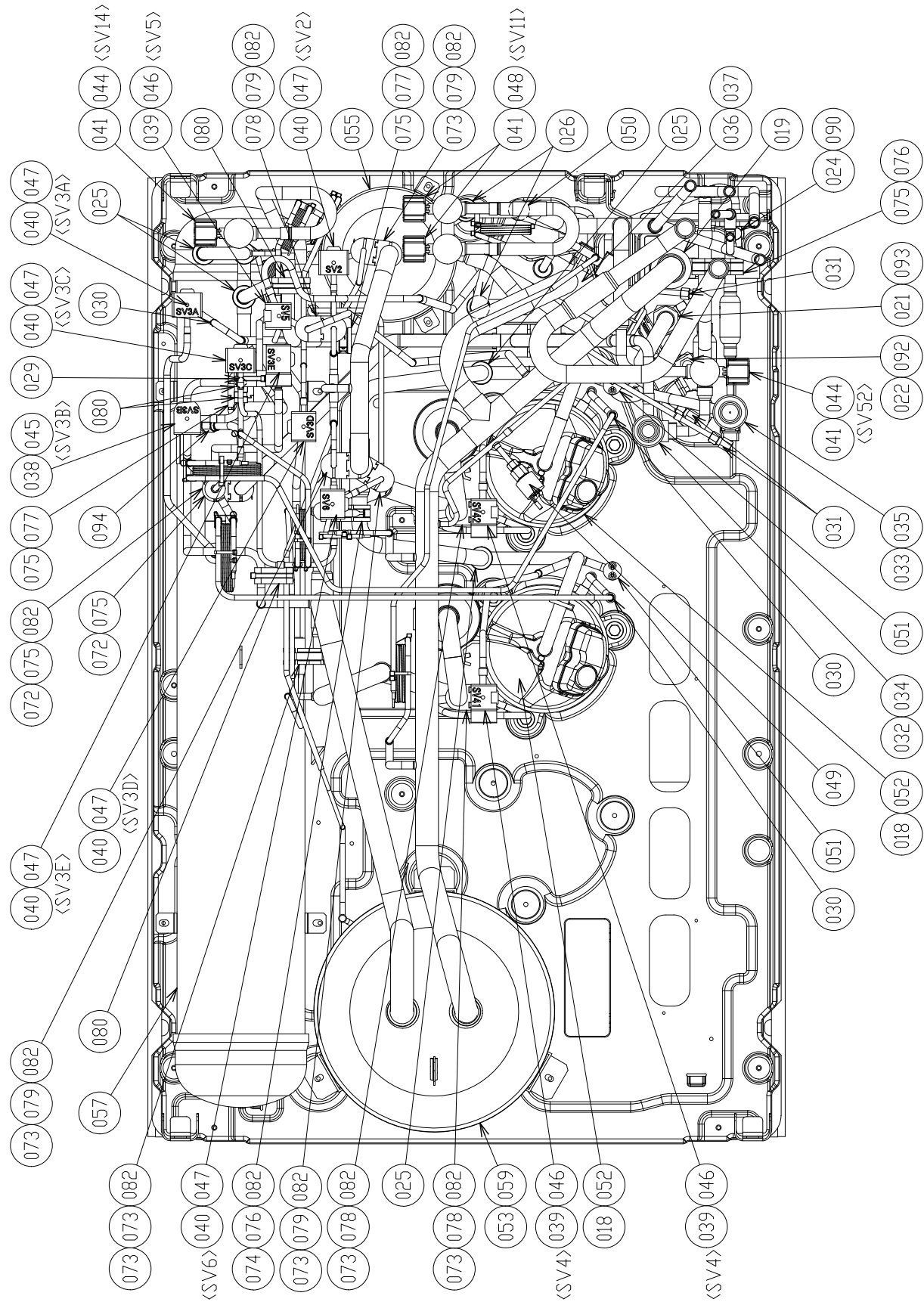

**MMY-MAP1206FT8(J)P, MAP1406FT8(J)P,
 MMY-MAP1206FT7(J)P, MAP1406FT7(J)P,
 MMY-MAP1206FT8P-A, MAP1406FT8P-A**

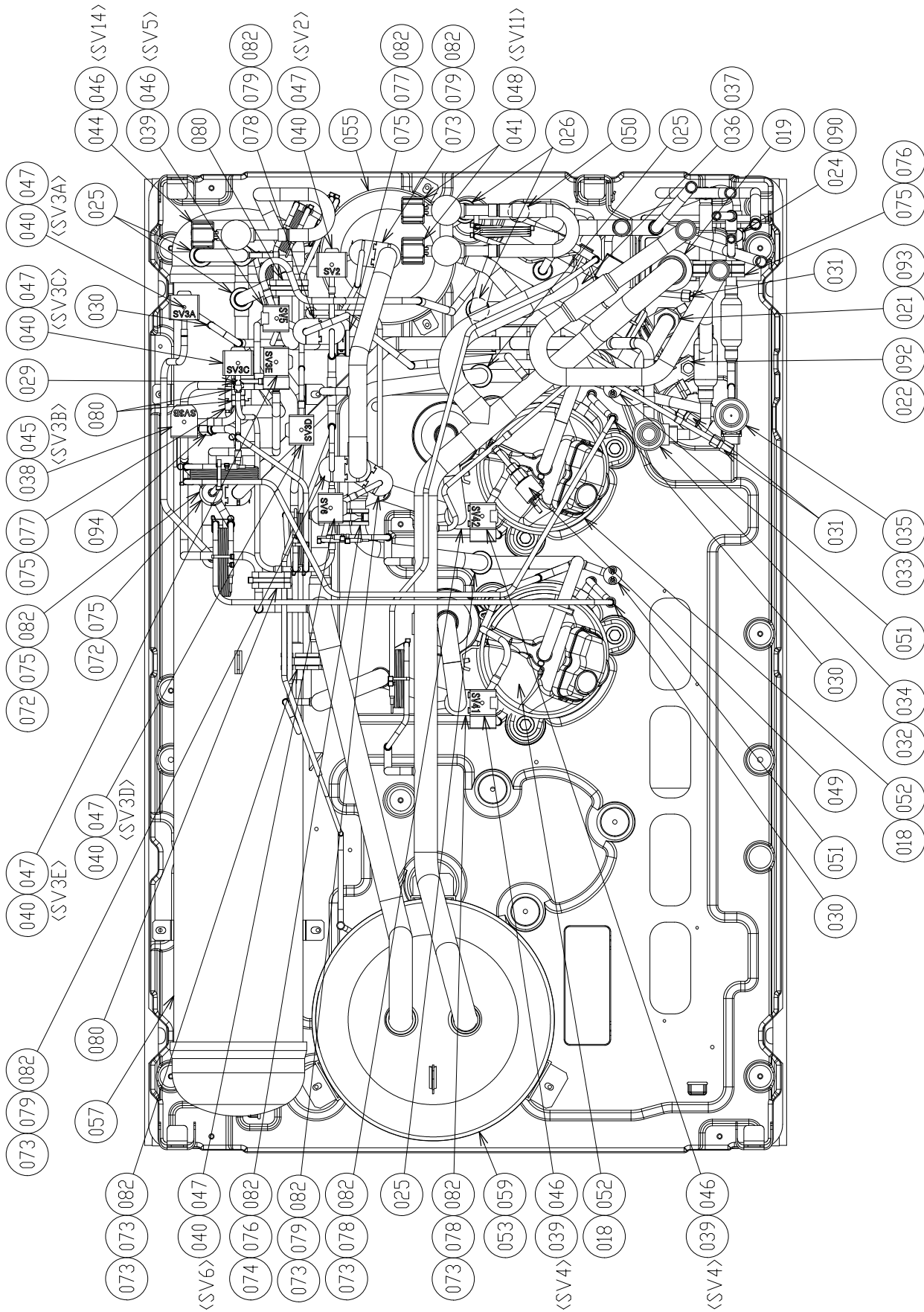

REFRIGERATION CIRCUIT DIAGRAM
MMY-MAP1206FT8(J)P-E, MAP1406FT8(J)P-E,
MMY-MAP1206FT8(J)P-TR, MAP1406FT8(J)P-TR,
MMY-MAP1206FT8(J)P-UK, MAP1406FT8(J)P-UK

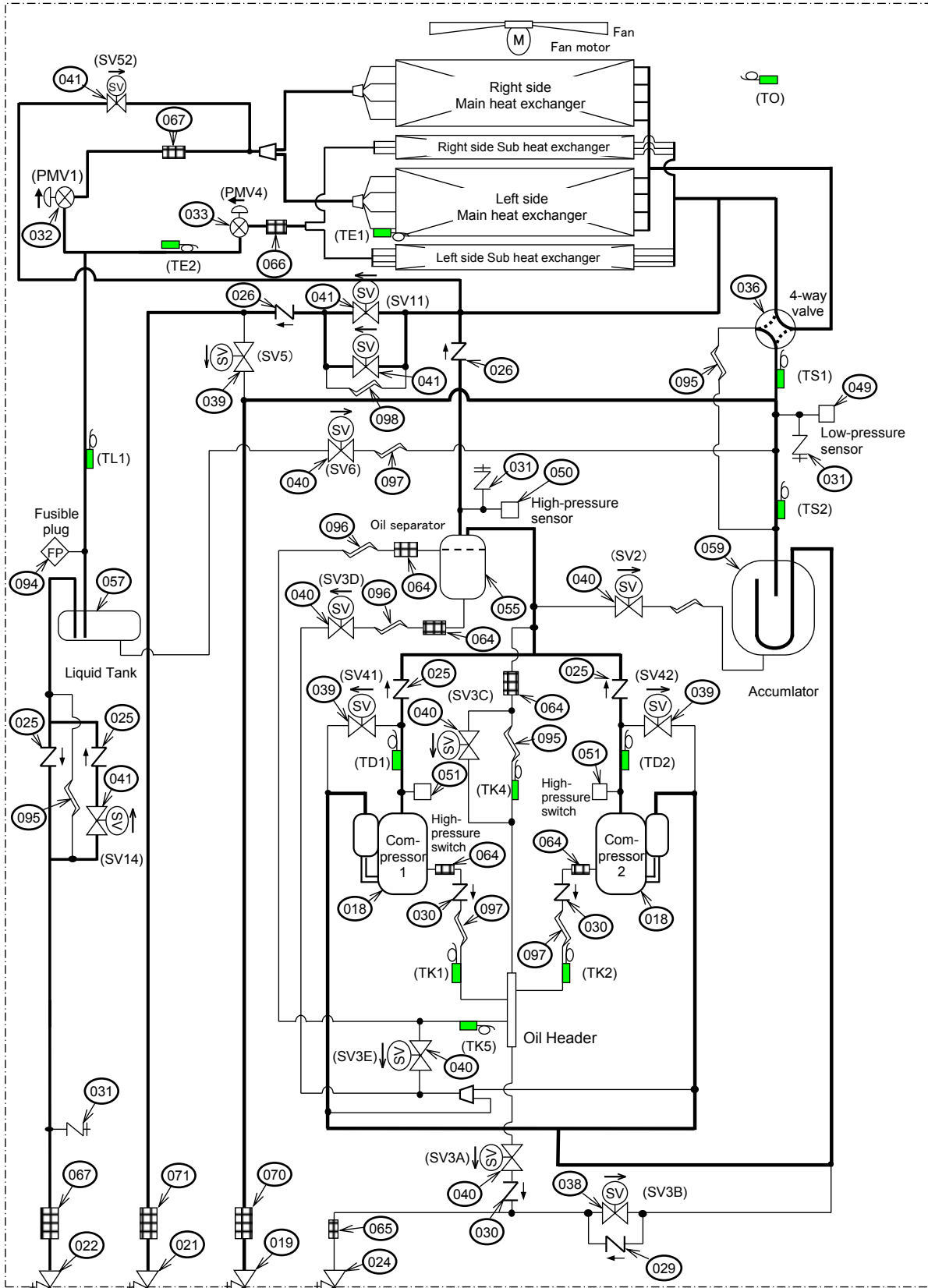

Liquid side Service valve
 Discharge-gas side Service valve
 Suction-gas side Service valve
 Balance pipe Service valve

Symbol						
Solenoid valve	Capillary tube	Check valve	Check joint	Strainer	Temperature sensor	Distributor

REFRIGERATION CIRCUIT DIAGRAM
MMY-MAP1206FT8(J)P, MAP1406FT8(J)P,
MMY-MAP1206FT7(J)P, MAP1406FT7(J)P,
MMY-MAP1206FT8P-A, MAP1406FT8P-A

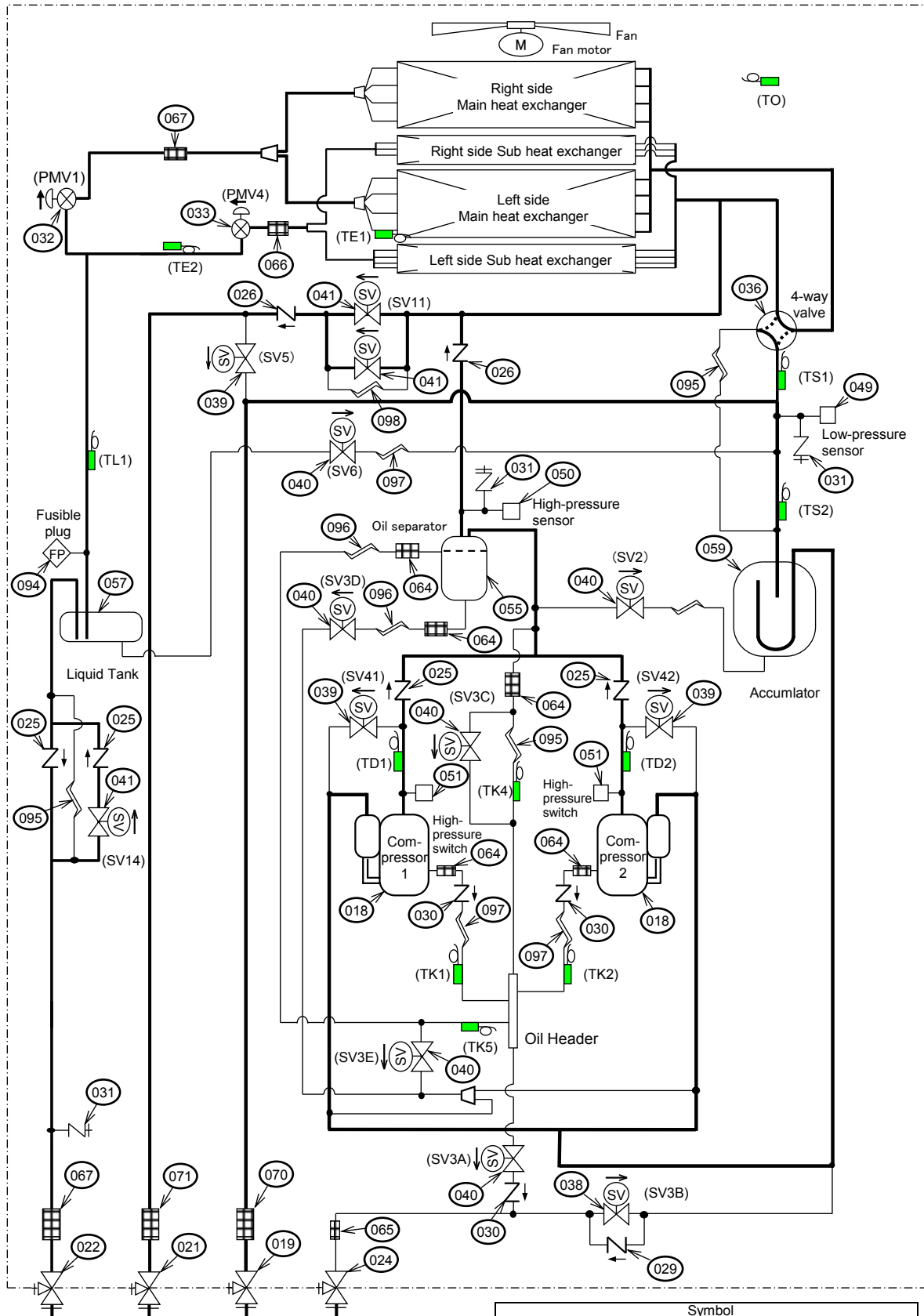

Liquid side Service valve
 Discharge-gas side Service valve
 Suction-gas side Service valve
 Balance pipe Service valve

Symbol						
Solenoid valve	Capillary tube	Check valve	Check joint	Strainer	Temperature sensor	Distributor

**MMY-MAP1606FT8(J)P-E, MAP1806FT8(J)P-E, MAP2006FT8(J)P-E,
 MMY-MAP1606FT8(J)P-TR, MAP1806FT8(J)P-TR, MAP2006FT8(J)P-TR,
 MMY-MAP1606FT8(J)P, MAP1806FT8(J)P, MAP2006FT8(J)P,
 MMY-MAP1606FT7(J)P, MAP1806FT7(J)P, MAP2006FT7(J)P,
 MMY-MAP1606FT8P-A, MAP1806FT8P-A, MAP2006FT8P-A,
 MMY-MAP1606FT8(J)P-UK, MAP1806FT8(J)P-UK, MAP2006FT8(J)P-UK**

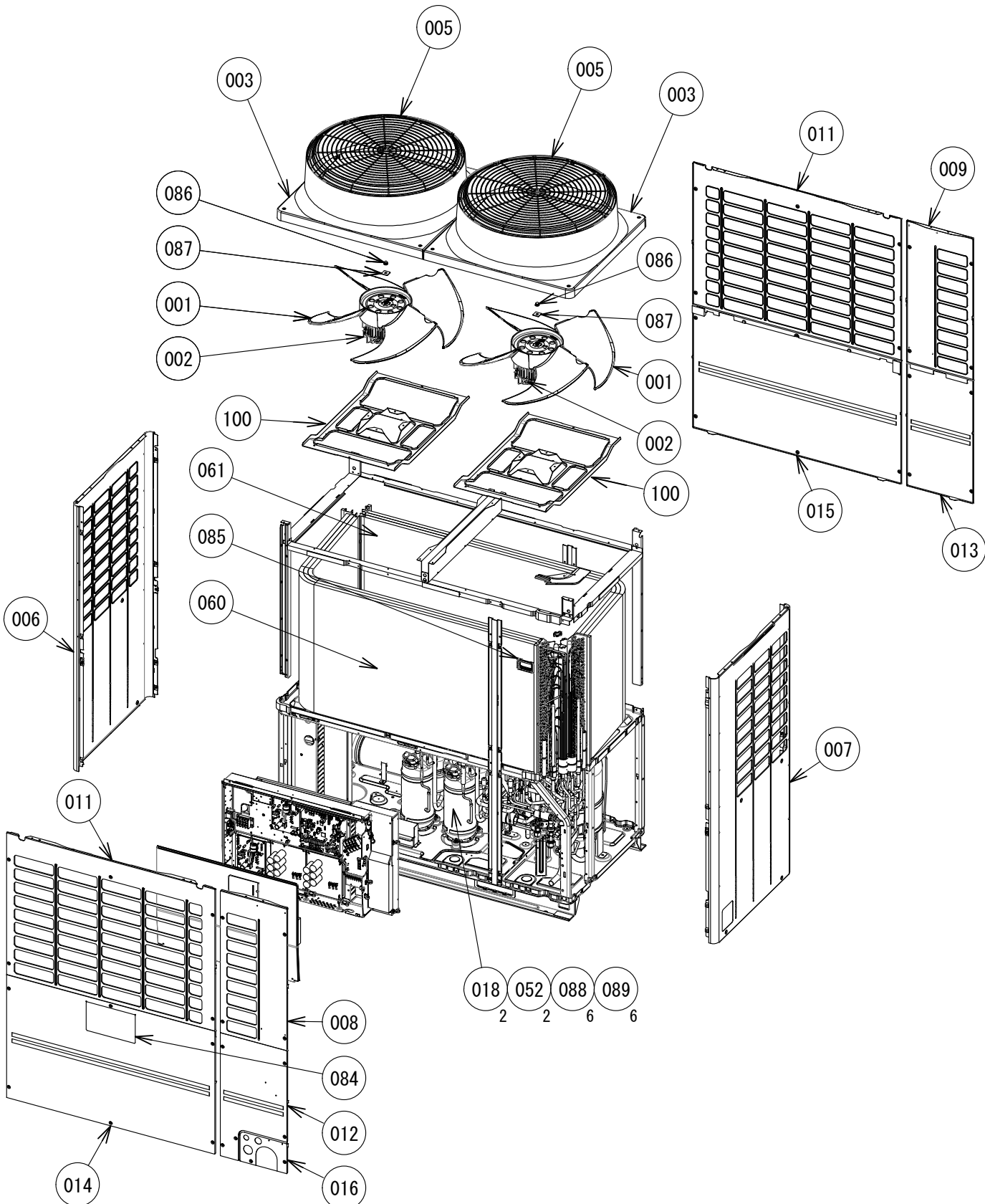

**MMY-MAP1606FT8(J)P, MAP1806FT8(J)P, MAP2006FT8(J)P,
 MMY-MAP1606FT7(J)P, MAP1806FT7(J)P, MAP2006FT7(J)P,
 MMY-MAP1606FT8P-A, MAP1806FT8P-A, MAP2006FT8P-A**

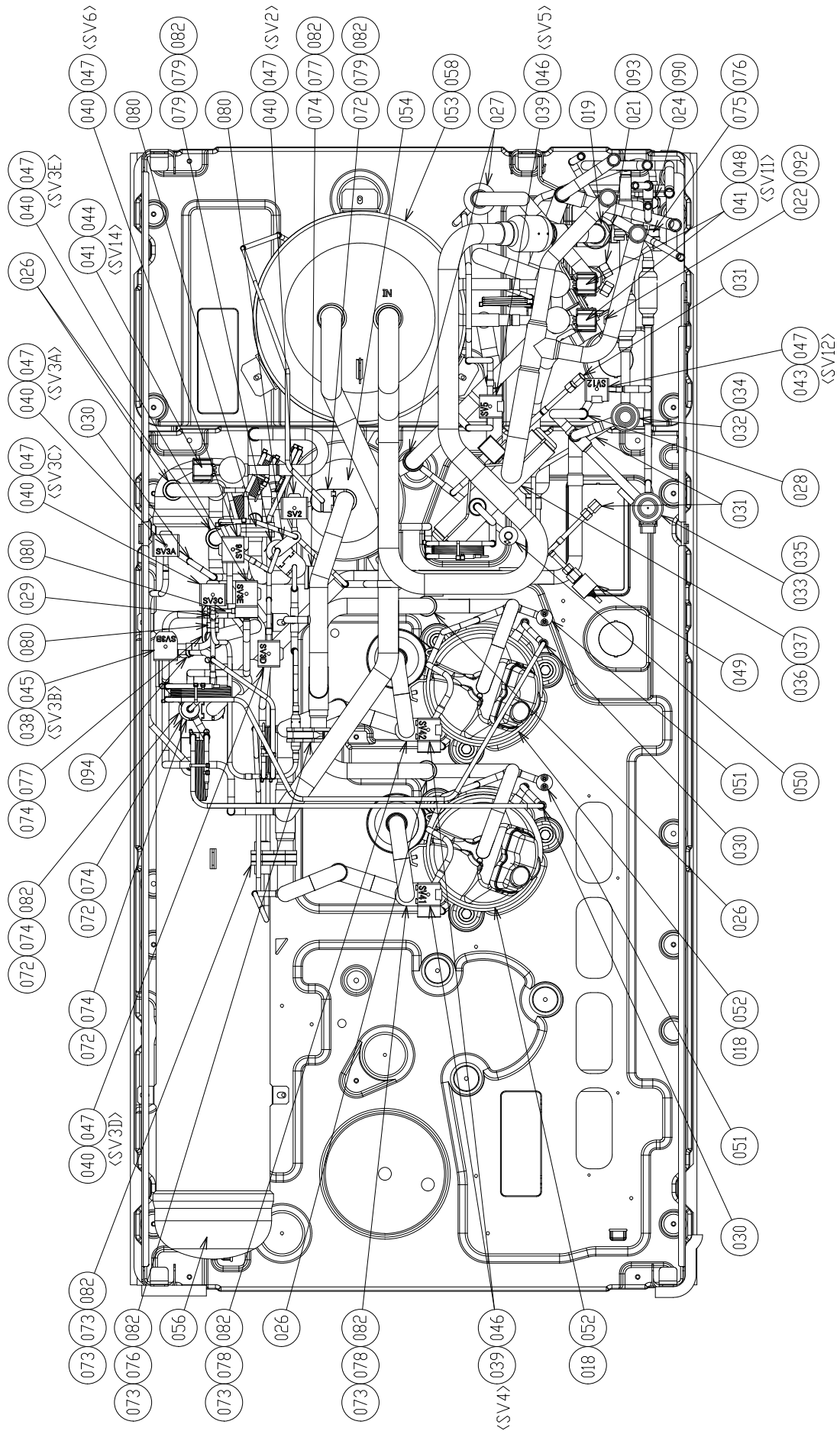

REFRIGERATION CIRCUIT DIAGRAM

MMY-MAP1606FT8(J)P-E, MAP1806FT8(J)P-E, MAP2006FT8(J)P-E,
 MMY-MAP1606FT8(J)P-TR, MAP1806FT8(J)P-TR, MAP2006FT8(J)P-TR,
 MMY-MAP1606FT8(J)P-UK, MAP1806FT8(J)P-UK, MAP2006FT8(J)P-UK

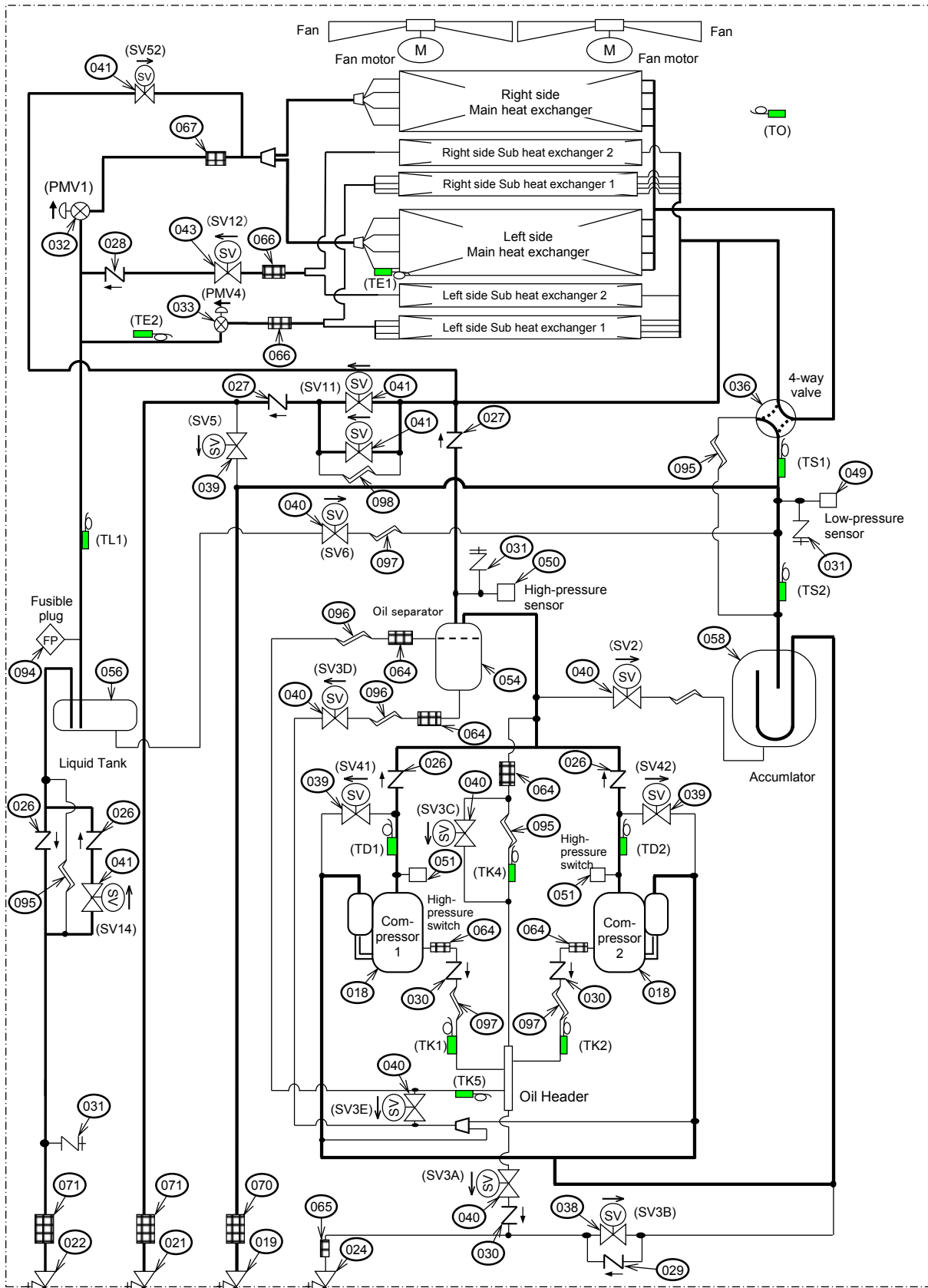

Liquid side Service valve
 Discharge-gas side Service valve
 Suction-gas side Service valve
 Balance pipe Service valve

Symbol					
Solenoid valve	Capillary tube	Check valve	Check joint	Strainer	Temperature sensor

REFRIGERATION CIRCUIT DIAGRAM

MMY-MAP1606FT8(J)P, MAP1806FT8(J)P, MAP2006FT8(J)P,
 MMY-MAP1606FT7(J)P, MAP1806FT7(J)P, MAP2006FT7(J)P,
 MMY-MAP1606FT8P-A, MAP1806FT8P-A, MAP2006FT8P-A

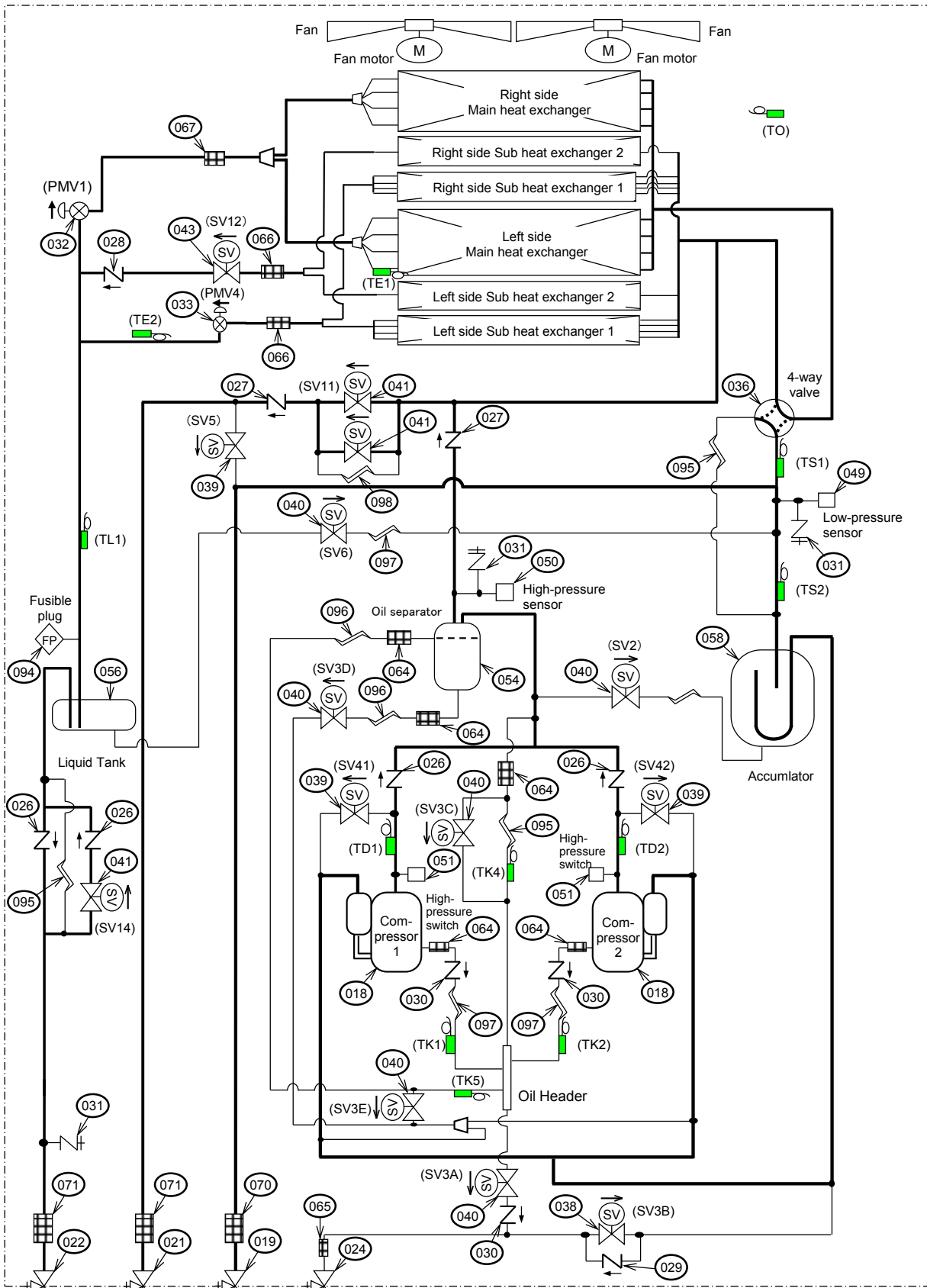

Liquid side Service valve
 Discharge-gas side Service valve
 Suction-gas side Service valve
 Balance pipe Service valve

Symbol						
Solenoid valve	Capillary tube	Check valve	Check joint	Strainer	Temperature sensor	Distributor

For FT8(J)P-E, FT8(J)P-TR, FT8(J)P-UK model

Ref. No.	Part No	Description	Q'ty/Set MMY-			
			MAP0806	MAP1006	MAP1206	MAP1406
001	43T20341	FAN, PROPELLER	1	1	1	1
002	43T20342	MOTOR, FAN, DC530-620V, 2300L	1	1	1	1
003	43T19354	CABINET, AIR OUTLET	1	1	1	1
004	43T19355	CABINET, SIDE, UP			2	2
005	43T19359	GUARD, FAN	1	1	1	1
006	43T00613	CABINET ASSY, SIDE, LEFT	1	1	1	1
007	43T00614	CABINET ASSY, SIDE, RIGHT	1	1	1	1
008	43T00624	CABINET, AIR INLET, FRONT	1	1		
009	43T00620	CABINET, AIR INLET, BACK	1	1		
010	43T00625	CABINET, AIR INLET, FRONT			1	1
011	43T00622	CABINET, AIR INLET, BACK			1	1
012	43T00615	CABINET ASSY, FRONT, DOWN	1	1		
013	43T00616	CABINET ASSY, BACK, DOWN	1	1		
014	43T00617	CABINET ASSY, FRONT, DOWN			1	1
015	43T00618	CABINET ASSY, BACK, DOWN			1	1
016	43T00623	PANEL	1	1	1	1
017	43T41458	COMPRESSOR, RA421A3TB-20MD	2	2		
018	43T41485	COMPRESSOR, RA641A3TB-20M			2	2
019	43T46393	VALVE, BALL, 25.4	1	1	1	1
020	43T46381	VALVE, BALL, SBV-JA5GTC-1	1	1		
021	43T46456	VALVE, BALL, SBV-JA6GTC-1			1	1
022	43T46386	VALVE, PACKED, 15.88 DIA			1	1
023	43T46467	VALVE, PACKED, 12.7	1	1		
024	43T46366	VALVE, PACKED, 9.52	1	1	1	1
025	43T46444	VALVE, CHECK, UCV-A1505DRQ5	2	2	4	4
026	43T46445	VALVE, CHECK, UCV-A1506DRQ5			2	2
028	43T46398	VALVE, CHECKED, BCV-804DY	4	4		
029	43T46399	VALVE, CHECK, BCV-603DY	1	1	1	1
030	43T46400	VALVE, CHECKED, BCV-302DY	3	3	3	3
031	43T46409	JOINT,CHECK	3	3	3	3
032	43T46447	VALVE, PMV, PAM-BA2YGTF-1 (φ4.8)	1	1	1	1
033	43T46394	VALVE, PMV	1	1	1	1
034	43T46449	COIL, PMV	1	1	1	1
035	43T46407	COIL, PMV	1	1	1	1
036	43T46452	VALVE, 4WAY, SHF-35B-67-04	1	1	1	1
037	43T46453	COIL, SOLENOID, AC220V-240 50HZ	1	1	1	1
038	43T46411	VALVE, 2WAY, VPV-603DQ2	1	1	1	1
039	43T46412	VALVE, 2WAY, FDF3A06	3	3	3	3
040	43T46454	VALVE, 2WAY, TEV-S1220DQ50	6	6	6	6
041	43T46488	VALVE, 2WAY, VPV	2	2	4	4
042	43T46459	VALVE, 2WAY, FDF6A42	1	1		
044	43T46490	COIL, VALVE, 2WAY	1	1	2	2
045	43T46403	COIL, SOLENOID, VPV-MOAJ510B0	1	1	1	1
046	43T46405	COIL, VALVE, 2WAY, FQ-G593	4	4	3	3
047	43T46455	COIL, VALVE, 2WAY, TEV-SMOAJ2170A1	6	6	6	6
048	43T46492	COIL, VALVE, 2WAY	1	1	2	2
049	43T50357	SENSOR ASSY, LOW PRESSURE	1	1	1	1
050	43T50358	SENSOR ASSY, HIGH PRESSURE	1	1	1	1
051	43T63345	SWITCH, PRESSURE	2	2	2	2
052	43T57303	HEATER, CASE, 29W 240V	2	2	2	2
053	43T57304	HEATER, CASE, 55W 240V	1	1	1	1
054	43T48314	SEPARATOR	1	1		
055	43T48307	SEPARATOR			1	1
056	43T48317	TANK, LIQUID	1	1		

Ref. No.	Part No	Description	Q'ty/Set MMY-			
			MAP0806	MAP1006	MAP1206	MAP1406
057	43T48318	TANK, LIQUID			1	1
058	43T48313	ACCUMULATOR	1	1		
059	43T48312	ACCUMULATOR			1	1
060	43T43531	CONDENSER ASSY, THREE ROW, LEFT	1	1		
061	43T43532	CONDENSER ASSY, THREE ROW, RIGHT	1	1		
062	43T43533	CONDENSER ASSY, THREE ROW, LEFT			1	1
063	43T43534	CONDENSER ASSY, THREE ROW, RIGHT			1	1
064	43T47388	STRAINER	5	5	5	5
065	43T47389	STRAINER	1	1	1	1
066	43T47390	STRAINER	3	3	1	1
067	43T47392	STRAINER			2	2
068	43T47393	STRAINER	1	1		
069	43T47394	STRAINER	1	1		
070	43T47395	STRAINER			1	1
071	43T47400	STRAINER			1	1
072	43T49348	RUBBER, SUPPORTER, PIPE	1	1	2	2
073	43T49349	RUBBER, SUPPORTER, PIPE	1	1	7	7
074	43T49350	RUBBER, SUPPORTER, PIPE	4	4	1	1
075	43T49351	RUBBER, SUPPORTER, PIPE	1	1	5	5
076	43T49352	RUBBER, SUPPORTER, PIPE	1	1	2	2
077	43T49353	RUBBER, SUPPORTER, PIPE			2	2
078	43T49354	RUBBER, SUPPORTER, PIPE	2	2	3	3
079	43T49355	RUBBER, SUPPORTER, PIPE	2	2	4	4
080	43T49347	RUBBER, SUPPORTER, PIPE	4	4	4	4
081	43T49360	RUBBER, SUPPORTER, PIPE	2	2		
082	43T49358	BAND, FIX	6	6	10	10
083	43T19333	HOLDER, SENSOR	12	12	12	12
084	43T01311	MARK, TOSHIBA	1	1	1	1
085	43T63358	HOLDER, NFC	1	1	1	1
086	43T39351	NUT, FLANGE	1	1	1	1
087	43T39350	WASHER	1	1	1	1
088	43T47385	BOLT, COMPRESSOR	6	6	6	6
089	43T49357	RUBBER, CUSHION	6	6	6	6
090	43T47332	BONNET, 3/8 IN	1	1	1	1
091	43T47333	BONNET, 1/2 IN	1	1		
092	43T47334	BONNET, 5/8 IN	1	1	1	1
093	43T47401	BONNET, 3/4 IN			1	1
094	43T49338	PLUG, FUSIBLE	1	1	1	1
095	43T47374	TUBE, CAPILLARY, ID 0.8	1	1	1	1
096	43T47375	TUBE, CAPILLARY, ID 1.0	1	1	1	1
097	43T47376	TUBE, CAPILLARY, ID 1.2	1	1	1	1
098	43T47406	TUBE, CAPILLARY, ID 1.5	1	1	1	1
099	43T85611 *1	OWNER'S MANUAL	1	1	1	1
	43T85612 *2					
	43T85662 *3					
100	43T00700	MOTOR, BASE	1	1	1	1

*1) For FT8(J)P-E model
*2) For FT8(J)P-TR model
*3) For FT8(J)P-UK model

Ref. No.	Part No	Description	Q'ty/Set MMY-		
			MAP1606	MAP1806	MAP2006
001	43T20341	FAN, PROPELLER	2	2	2
002	43T20343	MOTOR, FAN, DC530-620V, 3500L	2	2	2
003	43T19361	CABINET, AIR OUTLET	2	2	2
005	43T19359	GUARD, FAN	2	2	2
006	43T00663	CABINET ASSY, SIDE, LEFT	1	1	1
007	43T00664	CABINET ASSY, SIDE, RIGHT	1	1	1
008	43T00665	CABINET, AIR INLET, FRONT	1	1	1
009	43T00666	CABINET, AIR INLET, BACK	1	1	1
011	43T00622	CABINET, AIR INLET, BACK	2	2	2
012	43T00667	CABINET ASSY, FRONT, DOWN	1	1	1
013	43T00668	CABINET ASSY, BACK, DOWN	1	1	1
014	43T00669	CABINET ASSY, FRONT, DOWN	1	1	1
015	43T00618	CABINET ASSY, BACK, DOWN	1	1	1
016	43T00623	PANEL	1	1	1
018	43T41485	COMPRESSOR, RA641A3TB-20M	2	2	2
019	43T46393	VALVE, BALL, 25.4	1	1	1
021	43T46456	VALVE, BALL, SBV-JA6GTC-1	1	1	1
022	43T46386	VALVE, PACKED, 15.88 DIA	1	1	1
024	43T46366	VALVE, PACKED, 9.52	1	1	1
026	43T46445	VALVE, CHECK, UCV-A1506DRQ5	4	4	4
027	43T46446	VALVE, CHECK, UCV-A1507DR	2	2	2
028	43T46398	VALVE, CHECKED, BCV-804DY	1	1	1
029	43T46399	VALVE, CHECK, BCV-603DY	1	1	1
030	43T46400	VALVE, CHECKED, BCV-302DY	3	3	3
031	43T46409	JOINT,CHECK	3	3	3
032	43T46447	VALVE, PMV, PAM-BA2YGTF-1 (φ4.8)	1	1	1
033	43T46394	VALVE, PMV	1	1	1
034	43T46449	COIL, PMV	1	1	1
035	43T46407	COIL, PMV	1	1	1
036	43T46452	VALVE, 4WAY, SHF-35B-67-04	1	1	1
037	43T46453	COIL, SOLENOID, AC220V-240 50HZ	1	1	1
038	43T46411	VALVE , 2WAY, VPV-603DQ2	1	1	1
039	43T46412	VALVE, 2WAY, FDF3A06	3	3	3
040	43T46454	VALVE, 2WAY, TEV-S1220DQ50	6	6	6
041	43T46488	VALVE, 2WAY, VPV	4	4	4
043	43T46468	VALVE, 2WAY, TEV-S1920D	1	1	1
044	43T46490	COIL, VALVE, 2WAY	2	2	2
045	43T46403	COIL, SOLENOID, VPV-MOAJ510B0	1	1	1
046	43T46405	COIL, VALVE, 2WAY, FQ-G593	3	3	3
047	43T46455	COIL, VALVE, 2WAY, TEV-SMOAJ2170A1	7	7	7
048	43T46492	COIL, VALVE, 2WAY	2	2	2
049	43T50357	SENSOR ASSY, LOW PRESSURE	1	1	1
050	43T50358	SENSOR ASSY, HIGH PRESSURE	1	1	1
051	43T63345	SWITCH, PRESSURE	2	2	2
052	43T57303	HEATER, CASE, 29W 240V	2	2	2
053	43T57304	HEATER, CASE, 55W 240V	1	1	1
054	43T48307	SEPARATOR	1	1	1
056	43T48318	TANK, LIQUID	1	1	1

Ref. No.	Part No	Description	Q'ty/Set MMY-		
			MAP1606	MAP1806	MAP2006
058	43T48312	ACCUMULATOR	1	1	1
060	43T43535	CONDENSER ASSY, THREE ROW, LEFT	1	1	1
061	43T43536	CONDENSER ASSY, THREE ROW, RIGHT	1	1	1
064	43T47388	STRAINER	5	5	5
065	43T47389	STRAINER	1	1	1
066	43T47390	STRAINER	2	2	2
067	43T47392	STRAINER	1	1	1
070	43T47395	STRAINER	1	1	1
071	43T47400	STRAINER	2	2	2
072	43T49348	RUBBER, SUPPORTER, PIPE	4	4	4
073	43T49349	RUBBER, SUPPORTER, PIPE	5	5	5
074	43T49350	RUBBER, SUPPORTER, PIPE	5	5	5
075	43T49351	RUBBER, SUPPORTER, PIPE	1	1	1
076	43T49352	RUBBER, SUPPORTER, PIPE	2	2	2
077	43T49353	RUBBER, SUPPORTER, PIPE	2	2	2
078	43T49354	RUBBER, SUPPORTER, PIPE	2	2	2
079	43T49355	RUBBER, SUPPORTER, PIPE	3	3	3
080	43T49347	RUBBER, SUPPORTER, PIPE	3	3	3
082	43T49358	BAND, FIX	9	9	9
083	43T19333	HOLDER, SENSOR	12	12	12
084	43T01311	MARK, TOSHIBA	1	1	1
085	43T63358	HOLDER, NFC	1	1	1
086	43T39351	NUT, FLANGE	2	2	2
087	43T39350	WASHER	2	2	2
088	43T47385	BOLT, COMPRESSOR	6	6	6
089	43T49357	RUBBER, CUSHION	6	6	6
090	43T47332	BONNET, 3/8 IN	1	1	1
092	43T47334	BONNET, 5/8 IN	1	1	1
093	43T47401	BONNET, 3/4 IN	1	1	1
094	43T49338	PLUG, FUSIBLE	1	1	1
095	43T47374	TUBE, CAPILLARY, ID 0.8	1	1	1
096	43T47375	TUBE, CAPILLARY, ID 1.0	1	1	1
097	43T47376	TUBE, CAPILLARY, ID 1.2	1	1	1
098	43T47406	TUBE, CAPILLARY, ID 1.5	1	1	1
099	43T85611 *1	OWNER'S MANUAL	1	1	1
	43T85612 *2				
	43T85662 *3				
100	43T00700	MOTOR, BASE	2	2	2

- *1) For FT8(J)P-E model
- *2) For FT8(J)P-TR model
- *3) For FT8(J)P-UK model

For FT8(J)P, FT7(J)P, FT8P-A model

Ref. No.	Part No.	Description	Q'ty/Set MMY-			
			MAP0806	MAP1006	MAP1206	MAP1406
001	43T20341	FAN, PROPELLER	1	1	1	1
002	43T20342	MOTOR, FAN, DC530-620V, 2300L	1	1	1	1
003	43T19354	CABINET, AIR OUTLET	1	1	1	1
004	43T19355	CABINET, SIDE, UP			2	2
005	43T19353	GUARD, FAN	1	1	1	1
006	43T00613	CABINET ASSY, SIDE, LEFT	1	1	1	1
007	43T00614	CABINET ASSY, SIDE, RIGHT	1	1	1	1
008	43T00624	CABINET, AIR INLET, FRONT	1	1		
009	43T00620	CABINET, AIR INLET, BACK	1	1		
010	43T00625	CABINET, AIR INLET, FRONT			1	1
011	43T00622	CABINET, AIR INLET, BACK			1	1
012	43T00615	CABINET ASSY, FRONT, DOWN	1	1		
013	43T00616	CABINET ASSY, BACK, DOWN	1	1		
014	43T00617	CABINET ASSY, FRONT, DOWN			1	1
015	43T00618	CABINET ASSY, BACK, DOWN			1	1
016	43T00623	PANEL	1	1	1	1
017	43T41458 ^{*4}	COMPRESSOR, RA421A3TB-20MD	2	2		
018	43T41485 ^{*4}	COMPRESSOR, RA641A3TB-20M			2	2
019	43T46393	VALVE, BALL, 25.4	1	1	1	1
020	43T46381	VALVE, BALL, SBV-JA5GTC-1	1	1		
021	43T46456	VALVE, BALL, SBV-JA6GTC-1			1	1
022	43T46386	VALVE, PACKED, 15.88 DIA			1	1
023	43T46467	VALVE, PACKED, 12.7	1	1		
024	43T46366	VALVE, PACKED, 9.52	1	1	1	1
025	43T46444	VALVE, CHECK, UCV-A1505DRQ5	2	2	4	4
026	43T46445	VALVE, CHECK, UCV-A1506DRQ5			2	2
028	43T46398	VALVE, CHECKED, BCV-804DY	4	4		
029	43T46399	VALVE, CHECK, BCV-603DY	1	1	1	1
030	43T46400	VALVE, CHECKED, BCV-302DY	3	3	3	3
031	43T46409	JOINT,CHECK	3	3	3	3
032	43T46447	VALVE, PMV, PAM-BA2YGTF-1 (φ4.8)	1	1	1	1
033	43T46394	VALVE, PMV	1	1	1	1
034	43T46449	COIL, PMV	1	1	1	1
035	43T46407	COIL, PMV	1	1	1	1
036	43T46452	VALVE, 4WAY, SHF-35B-67-04	1	1	1	1
037	43T46453 ^{*1,3}	COIL, SOLENOID, AC220V-240 50HZ	1	1	1	1
	43T46457 ^{*2}	COIL, SOLENOID, AC208-230V 60HZ				
038	43T46411	VALVE, 2WAY, VPV-603DQ2	1	1	1	1
039	43T46412	VALVE, 2WAY, FDF3A06	3	3	3	3
040	43T46454	VALVE, 2WAY, TEV-S1220DQ50	6	6	6	6
041	43T46488 ^{*1,3}	VALVE, 2WAY, VPV	2	2	3	3
	43T46489 ^{*2}	VALVE, 2WAY, VPV				
044	43T46490 ^{*1,3}	COIL, VALVE, 2WAY	1	1	1	1
	43T46491 ^{*2}	COIL, VALVE, 2WAY				
045	43T46403 ^{*1,3}	COIL, SOLENOID, VPV-MOAJ510B0	1	1	1	1
	43T46404 ^{*2}	COIL, SOLENOID, VPV-MOAJ1843A0				
046	43T46405 ^{*1,3}	COIL, VALVE, 2WAY, FQ-G593	3	3	3	3
	43T46406 ^{*2}	COIL, VALVE, 2WAY, FQ-D640				
047	43T46455 ^{*1,3}	COIL, VALVE, 2WAY, TEV-SMOAJ2170A1	6	6	6	6
	43T46458 ^{*2}	COIL, VALVE, 2WAY, TEV-SMOAJ2247A1				
048	43T46492 ^{*1,3}	COIL, VALVE, 2WAY	1	1	2	2
	43T46493 ^{*2}	COIL, VALVE, 2WAY				
049	43T50357	SENSOR ASSY, LOW PRESSURE	1	1	1	1
050	43T50358	SENSOR ASSY, HIGH PRESSURE	1	1	1	1
051	43T63345	SWITCH, PRESSURE	2	2	2	2
052	43T57303	HEATER, CASE, 29W 240V	2	2	2	2
053	43T57304	HEATER, CASE, 55W 240V	1	1	1	1

*1) For FT8(J)P model

*2) For FT7(J)P model

*3) For FT8(J)P-A model

*4) Due to the service compressor for Brazil is now acquiring the INMETRO certification (No371/328/163/(402)), we don't carry it as a service parts. Thus please contact the sales company when necessary.

Ref. No.	Part No.	Description	Q'ty/Set MMY-			
			MAP0806	MAP1006	MAP1206	MAP1406
054	43T48314	SEPARATOR	1	1		
055	43T48307	SEPARATOR			1	1
056	43T48317	TANK, LIQUID	1	1		
057	43T48318	TANK, LIQUID			1	1
058	43T48313	ACCUMULATOR	1	1		
059	43T48312	ACCUMULATOR			1	1
060	43T43531	CONDENSER ASSY, THREE ROW, LEFT	1	1		
061	43T43532	CONDENSER ASSY, THREE ROW, RIGHT	1	1		
062	43T43533	CONDENSER ASSY, THREE ROW, LEFT			1	1
063	43T43534	CONDENSER ASSY, THREE ROW, RIGHT			1	1
064	43T47388	STRAINER	5	5	5	5
065	43T47389	STRAINER	1	1	1	1
066	43T47390	STRAINER	3	3	1	1
067	43T47392	STRAINER			2	2
068	43T47393	STRAINER	1	1		
069	43T47394	STRAINER	1	1		
070	43T47395	STRAINER			1	1
071	43T47400	STRAINER			1	1
072	43T49348	RUBBER, SUPPORTER, PIPE	1	1	2	2
073	43T49349	RUBBER, SUPPORTER, PIPE	1	1	7	7
074	43T49350	RUBBER, SUPPORTER, PIPE	4	4	1	1
075	43T49351	RUBBER, SUPPORTER, PIPE	1	1	5	5
076	43T49352	RUBBER, SUPPORTER, PIPE	1	1	2	2
077	43T49353	RUBBER, SUPPORTER, PIPE			2	2
078	43T49354	RUBBER, SUPPORTER, PIPE	2	2	3	3
079	43T49355	RUBBER, SUPPORTER, PIPE	2	2	4	4
080	43T49347	RUBBER, SUPPORTER, PIPE	4	4	4	4
081	43T49360	RUBBER, SUPPORTER, PIPE	2	2		
082	43T49358	BAND, FIX	6	6	10	10
083	43T19333	HOLDER, SENSOR	12	12	12	12
084	43T01311	MARK, TOSHIBA	1	1	1	1
085	43T63358	HOLDER, NFC	1	1	1	1
086	43T39351	NUT, FLANGE	1	1	1	1
087	43T39350	WASHER	1	1	1	1
088	43T47385	BOLT, COMPRESSOR	6	6	6	6
089	43T49357	RUBBER, CUSHION	6	6	6	6
090	43T47332	BONNET, 3/8 IN	1	1	1	1
091	43T47333	BONNET, 1/2 IN	1	1		
092	43T47334	BONNET, 5/8 IN	1	1	1	1
093	43T47401	BONNET, 3/4 IN			1	1
094	43T49338	PLUG, FUSIBLE	1	1	1	1
095	43T47374	TUBE, CAPILLARY, ID 0.8	1	1	1	1
096	43T47375	TUBE, CAPILLARY, ID 1.0	1	1	1	1
097	43T47376	TUBE, CAPILLARY, ID 1.2	1	1	1	1
098	43T47406	TUBE, CAPILLARY, ID 1.5	1	1	1	1
099	43T85626 ^{*1}	OWNER'S MANUAL	1	1	1	1
	43T85627 ^{*2}	OWNER'S MANUAL				
	43T85628 ^{*3}	OWNER'S MANUAL				
100	43T00700	MOTOR, BASE	1	1	1	1

- *1) For FT8(J)P model
- *2) For FT7(J)P model
- *3) For FT8(J)P-A model

Ref. No.	Part No.	Description	Q'ty/Set MMY-		
			MAP1606	MAP1806	MAP2006
001	43T20341	FAN, PROPELLER	2	2	2
002	43T20343	MOTOR, FAN, DC530-620V, 3500L	2	2	2
003	43T19361	CABINET, AIR OUTLET	2	2	2
005	43T19353	GUARD, FAN	2	2	2
006	43T00663	CABINET ASSY, SIDE, LEFT	1	1	1
007	43T00664	CABINET ASSY, SIDE, RIGHT	1	1	1
008	43T00665	CABINET, AIR INLET, FRONT	1	1	1
009	43T00666	CABINET, AIR INLET, BACK	1	1	1
011	43T00622	CABINET, AIR INLET, BACK	2	2	2
012	43T00667	CABINET ASSY, FRONT, DOWN	1	1	1
013	43T00668	CABINET ASSY, BACK, DOWN	1	1	1
014	43T00669	CABINET ASSY, FRONT, DOWN	1	1	1
015	43T00618	CABINET ASSY, BACK, DOWN	1	1	1
016	43T00623	PANEL	1	1	1
018	43T41485 *4	COMPRESSOR, RA641A3TB-20M	2	2	2
019	43T46393	VALVE, BALL, 25.4	1	1	1
021	43T46456	VALVE, BALL, SBV-JA6GTC-1	1	1	1
022	43T46386	VALVE, PACKED, 15.88 DIA	1	1	1
024	43T46366	VALVE, PACKED, 9.52	1	1	1
026	43T46445	VALVE, CHECK, UCV-A1506DRQ5	4	4	4
027	43T46446	VALVE, CHECK, UCV-A1507DR	2	2	2
028	43T46398	VALVE, CHECKED, BCV-804DY	1	1	1
029	43T46399	VALVE, CHECK, BCV-603DY	1	1	1
030	43T46400	VALVE, CHECKED, BCV-302DY	3	3	3
031	43T46409	JOINT,CHECK	3	3	3
032	43T46447	VALVE, PMV, PAM-BA2YGTF-1 (φ4.8)	1	1	1
033	43T46394	VALVE, PMV	1	1	1
034	43T46449	COIL, PMV	1	1	1
035	43T46407	COIL, PMV	1	1	1
036	43T46452	VALVE, 4WAY, SHF-35B-67-04	1	1	1
037	43T46453 *1,3	COIL, SOLENOID, AC220V-240 50HZ	1	1	1
	43T46457 *2	COIL, SOLENOID, AC208-230V 60HZ			
038	43T46411	VALVE , 2WAY, VPV-603DQ2	1	1	1
039	43T46412	VALVE, 2WAY, FDF3A06	3	3	3
040	43T46454	VALVE, 2WAY, TEV-S1220DQ50	6	6	6
041	43T46488 *1,3	VALVE, 2WAY, VPV	3	3	3
	43T46489 *2	VALVE, 2WAY, VPV			
043	43T46468	VALVE, 2WAY, TEV-S1920D	1	1	1
044	43T46490 *1,3	COIL, VALVE, 2WAY	1	1	1
	43T46491 *2	COIL, VALVE, 2WAY			
045	43T46403 *1,3	COIL, SOLENOID, VPV-MOAJ510B0	1	1	1
	43T46404 *2	COIL, SOLENOID, VPV-MOAQ1843A0			
046	43T46405 *1,3	COIL, VALVE, 2WAY, FQ-G593	3	3	3
	43T46406 *2	COIL, VALVE, 2WAY, FQ-D640			
047	43T46455 *1,3	COIL, VALVE, 2WAY, TEV-SMOAJ2170A1	7	7	7
	43T46458 *2	COIL, VALVE, 2WAY, TEV-SMOAQ2247A1			
048	43T46492 *1,3	COIL, VALVE, 2WAY	2	2	2
	43T46493 *2	COIL, VALVE, 2WAY			
049	43T50357	SENSOR ASSY, LOW PRESSURE	1	1	1
050	43T50358	SENSOR ASSY, HIGH PRESSURE	1	1	1
051	43T63345	SWITCH, PRESSURE	2	2	2
052	43T57303	HEATER, CASE, 29W 240V	2	2	2

*1) For FT8(J)P model

*2) For FT7(J)P model

*3) For FT8(J)P-A model

*4) Due to the service compressor for Brazil is now acquiring the INMETRO certification (No371/328/163/(402)), we don't carry it as a service parts.

Thus please contact the sales company when necessary.

Ref. No.	Part No.	Description	Q'ty/Set MMY-		
			MAP1606	MAP1806	MAP2006
053	43T57304	HEATER, CASE, 55W 240V	1	1	1
054	43T48307	SEPARATOR	1	1	1
056	43T48318	TANK, LIQUID	1	1	1
058	43T48312	ACCUMULATOR	1	1	1
060	43T43535	CONDENSER ASSY, THREE ROW, LEFT	1	1	1
061	43T43536	CONDENSER ASSY, THREE ROW, RIGHT	1	1	1
064	43T47388	STRAINER	5	5	5
065	43T47389	STRAINER	1	1	1
066	43T47390	STRAINER	2	2	2
067	43T47392	STRAINER	1	1	1
070	43T47395	STRAINER	1	1	1
071	43T47400	STRAINER	2	2	2
072	43T49348	RUBBER, SUPPORTER, PIPE	4	4	4
073	43T49349	RUBBER, SUPPORTER, PIPE	5	5	5
074	43T49350	RUBBER, SUPPORTER, PIPE	5	5	5
075	43T49351	RUBBER, SUPPORTER, PIPE	1	1	1
076	43T49352	RUBBER, SUPPORTER, PIPE	2	2	2
077	43T49353	RUBBER, SUPPORTER, PIPE	2	2	2
078	43T49354	RUBBER, SUPPORTER, PIPE	2	2	2
079	43T49355	RUBBER, SUPPORTER, PIPE	3	3	3
080	43T49347	RUBBER, SUPPORTER, PIPE	4	4	4
082	43T49358	BAND, FIX	9	9	9
083	43T19333	HOLDER, SENSOR	12	12	12
084	43T01311	MARK, TOSHIBA	1	1	1
085	43T63358	HOLDER, NFC	1	1	1
086	43T39351	NUT, FLANGE	2	2	2
087	43T39350	WASHER	2	2	2
088	43T47385	BOLT, COMPRESSOR	6	6	6
089	43T49357	RUBBER, CUSHION	6	6	6
090	43T47332	BONNET, 3/8 IN	1	1	1
092	43T47334	BONNET, 5/8 IN	1	1	1
093	43T47401	BONNET, 3/4 IN	1	1	1
094	43T49338	PLUG, FUSIBLE	1	1	1
095	43T47374	TUBE, CAPILLARY, ID 0.8	1	1	1
096	43T47375	TUBE, CAPILLARY, ID 1.0	1	1	1
097	43T47376	TUBE, CAPILLARY, ID 1.2	1	1	1
098	43T47406	TUBE, CAPILLARY, ID 1.5	1	1	1
099	43T85626 *1	OWNER'S MANUAL	1	1	1
	43T85627 *2	OWNER'S MANUAL			
	43T85628 *3	OWNER'S MANUAL			
100	43T00700	MOTOR, BASE	2	2	2

*1) For FT8(J)P model

*2) For FT7(J)P model

*3) For FT8(J)P-A model

16-2. Inverter Assembly

**MMY-MAP0806FT8(J)P-E, MAP1006FT8(J)P-E,
 MMY-MAP0806FT8(J)P-TR, MAP1006FT8(J)P-TR,
 MMY-MAP0806FT8(J)P, MAP1006FT8(J)P,
 AAMA5 D\$, \$* : H, D!5 žA5 D°\$\$* : H, D!5 ,
 AAMA5 D\$, \$* : H, D!5 žA5 D°\$\$* : H, D!5 ,
 MMY-MAP0806FT8(J)P-UK, MAP1006FT8(J)P-UK**

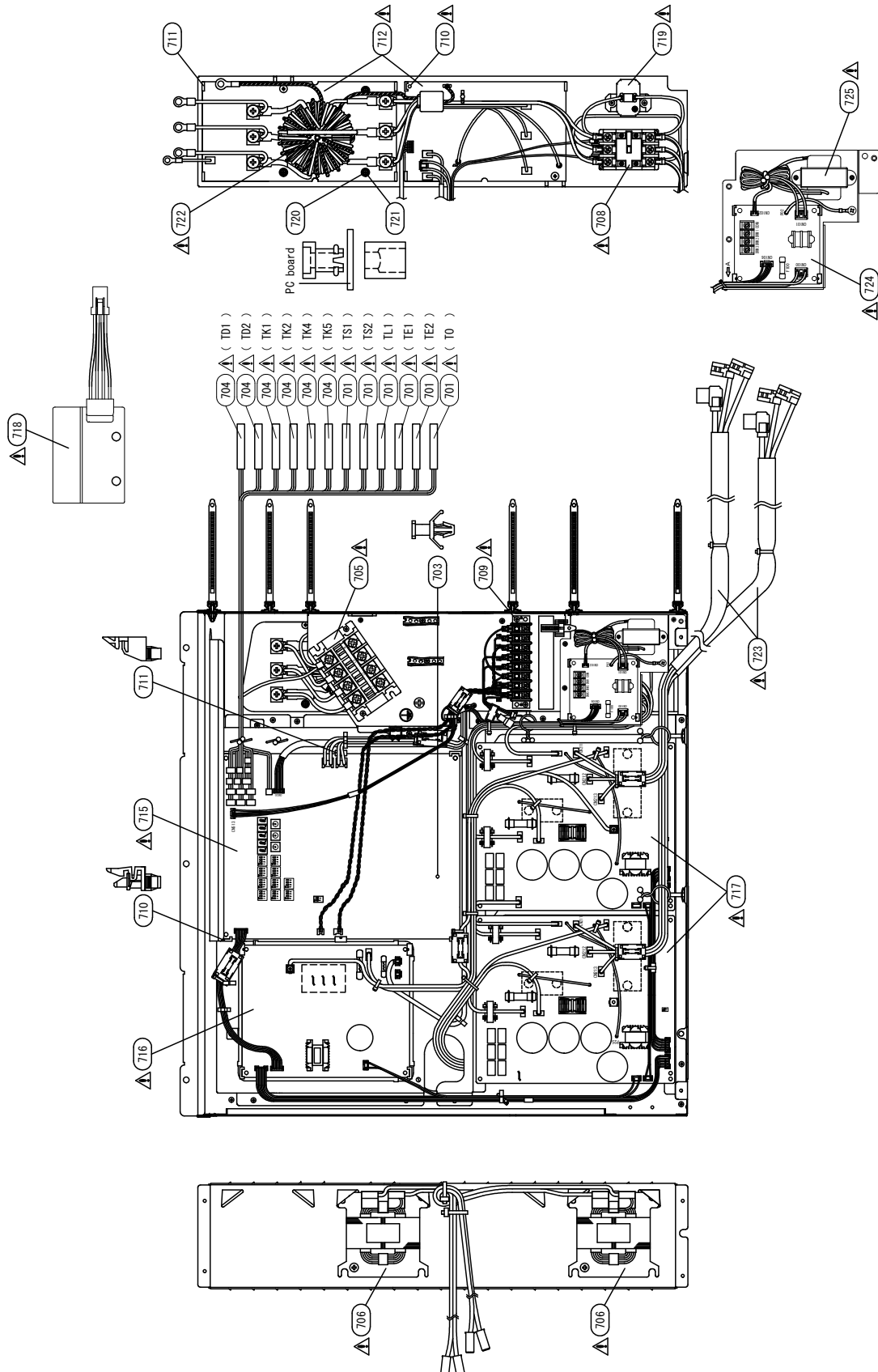

**MMY-MAP1206FT8(J)P-E, MAP1406FT8(J)P-E,
 MMY-MAP1206FT8(J)P-TR, MAP1406FT8(J)P-TR,
 MMY-MAP1206FT8(J)P, MAP1406FT8(J)P,
 MMY-MAP1206FT7(J)P, MAP1406FT7(J)P,
 MMY-MAP1206FT8P-A, MAP1406FT8P-A,
 MMY-MAP1206FT8(J)P-UK, MAP1406FT8(J)P-UK**

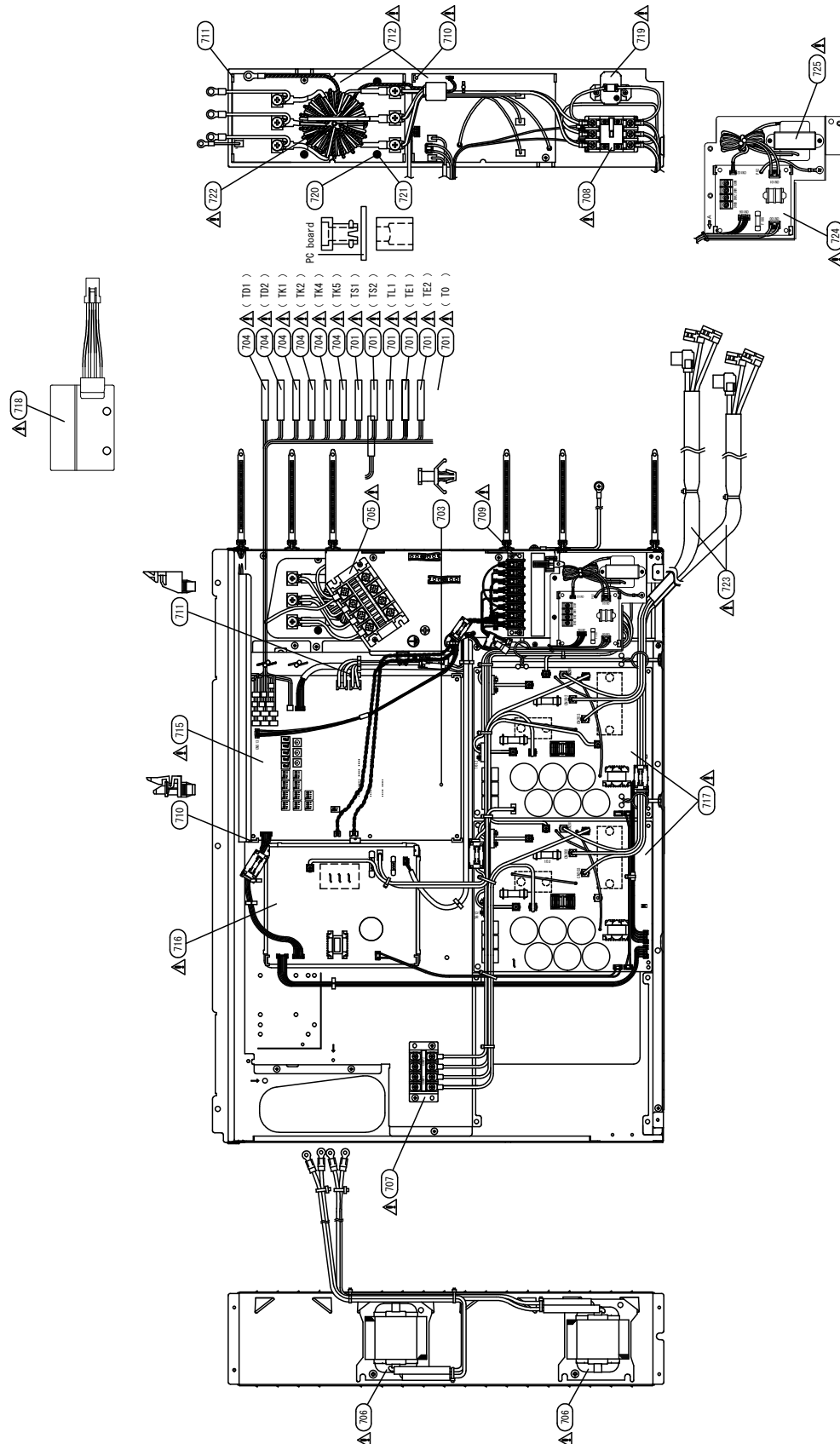

MMY-MAP1606FT8(J)P-E, MAP1806FT8(J)P-E, MAP2006FT8(J)P-E
MMY-MAP1606FT8(J)P-TR, MAP1806FT8(J)P-TR, MAP2006FT8(J)P-TR
MMY-MAP1606FT8(J)P, MAP1806FT8(J)P, MAP2006FT8(J)P,
MMY-MAP1606FT7(J)P,MAP1806FT7(J)P, MAP2006FT7(J)P,
MMY-MAP1606FT8P-A, MAP1806FT8P-A, MAP2006FT8P-A,
MMY-MAP1606FT8(J)P-UK, MAP1806FT8(J)P-UK, MAP2006FT8(J)P-UK

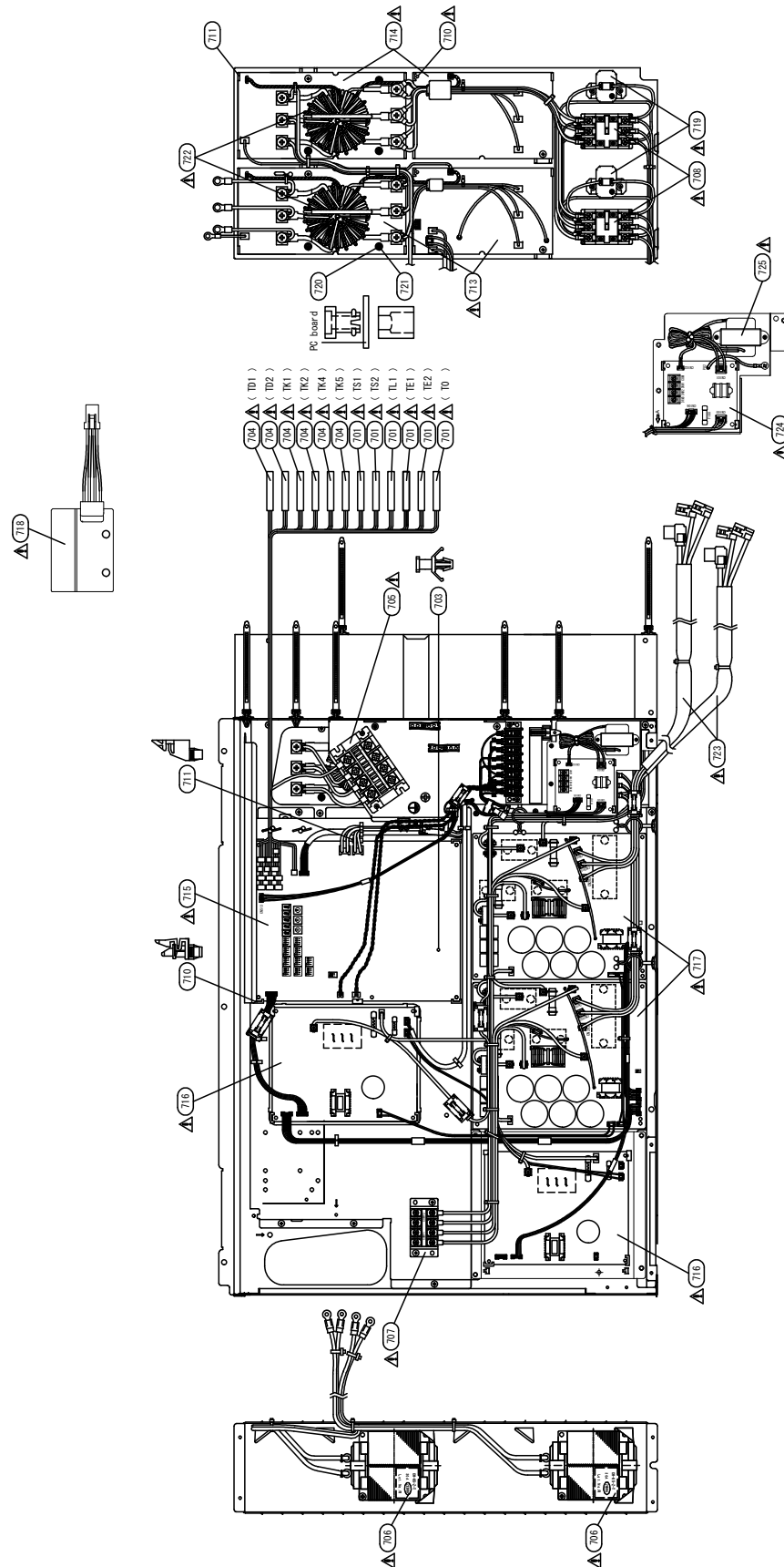

Ref. No.	Part No	Description	Q'ty/Set MMY-			
			MAP0806	MAP1006	MAP1206	MAP1406
701	43T50347	SENSOR ASSY, SERVICE	6	6	6	6
703	43T95303	SUPPORTER, ASSY	3	3	3	3
704	43T50348	SENSOR,TD(F6)	6	6	6	6
705	43T60437	TERMINAL, 4P	1	1	1	1
706	43T58317	REACTOR, CH-79	2	2		
	43T58330	REACTOR, CH-90			2	2
707	43T60453	TERMINAL, 4P			1	1
708	43T52320	CONTACTOR, MAGNETIC	1	1	1	1
709	43T60457	TERMINAL, 8P	1	1	1	1
710	43T95301	SUPPORT, SPACER	7	7	7	7
711	43T95302	SPACER(EDGE)	10	10	10	10
712	43T6V623	PC BOARD ASSY, NOISE FILTER, MCC-1608	1	1	1	1
715	43T6W386	PC BOARD ASSY, INTERFACE, MCC-1673	1	1	1	1
716	43T6V627	PC BOARD ASSY, FAN IPDU, MCC-1659	1	1	1	1
717	43T6V628	PC BOARD ASSY, COMP-IPDU, MCC-1669	2	2		
	43T6V629	PC BOARD ASSY, COMP-IPDU, MCC-1669			2	2
718	43T6V631	PC BOARD ASSY, NFC, MCC-1667	1	1	1	1
719	43T50345	THERMISTOR, PTC	1	1	1	1
720	43T96307	BUSHING	3	3	3	3
721	43T96306	COLLAR	3	3	3	3
722	43T55367	FILTER, LINE	1	1	1	1
723	43T60466	LEAD ASSY, COMPRESSOR	2	2		
	43T60467	LEAD ASSY, COMPRESSOR			2	2
724	42T6V646 *1	PC BOARD ASSY, DRC BOARD, MCC-1653	1	1	1	1
725	43T58323	TRANSFORMER (V-02 VRK)	1	1	1	1

*1) For FT8P-A model

Ref. No.	Part No	Description	Q'ty/Set		
			MAP1606	MAP1806	MMY- MAP2006
701	43T50347	SENSOR ASSY, SERVICE	6	6	6
703	43T95303	SUPPORTER, ASSY	3	3	3
704	43T50348	SENSOR,TD(F6)	6	6	6
705	43T60437	TERMINAL, 4P	1	1	1
706	43T58331	REACTOR, CH-65	2	2	2
707	43T60453	TERMINAL, 4P	1	1	1
708	43T52320	CONTACTOR, MAGNETIC	2	2	2
709	43T60457	TERMINAL, 8P	1	1	1
710	43T95301	SUPPORT, SPACER	10	10	10
711	43T95302	SPACER(EDGE)	18	18	18
713	43T6V624	PC BOARD ASSY, NOISE FILTER, MCC-1608	1	1	1
714	43T6V625	PC BOARD ASSY, NOISE FILTER, MCC-1608	1	1	1
715	43T6W386	PC BOARD ASSY, INTERFACE, MCC-1673	1	1	1
716	43T6V627	PC BOARD ASSY, FAN IPDU, MCC-1659	2	2	2
717	43T6V630	PC BOARD ASSY, COMP-IPDU, MCC-1660	2	2	2
718	43T6V631	PC BOARD ASSY, NFC, MCC-1667	1	1	1
719	43T50345	THERMISTOR, PTC	2	2	2
720	43T96307	BUSHING	6	6	6
721	43T96306	COLLAR	6	6	6
722	43T55366	FILTER, LINE	2	2	2
723	43T60468	LEAD ASSY, COMPRESSOR	2	2	2
724	42T6V646 *1	PC BOARD ASSY, DRC BOARD, MCC-1653	1	1	1
725	43T58323	TRANSFORMER (V-02 VRK)	1	1	1

*1) For FT8P-A model

16-3. Multi port FS unit

Models: RBM-Y1801F4PE/PE2 , RBM-Y1801F6PE/PE2

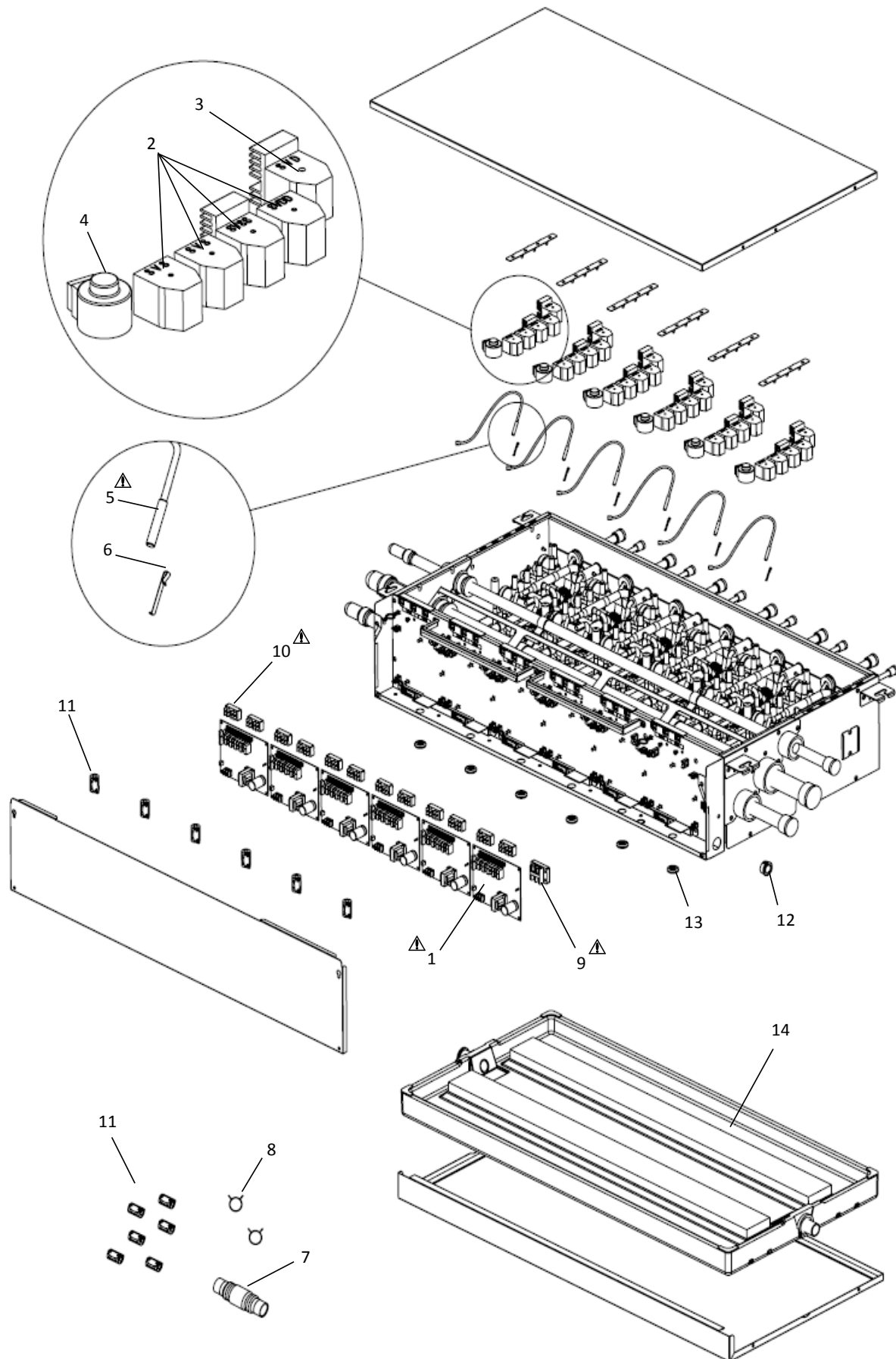

△	Location No.	Part No.	Description	RBM-Y1801			
				F4PE	F6PE	F4PE2	F6PE2
△	1	43T6V691	PC BOARD ASSY, MCC-1681	4	6	4	6
	2	43T46403	COIL, SOLENOID, VPV-MOAJ510B0	16	24		
	2	43T46404	COIL, SOLENOID, VPV-MOAJ1843A0			16	24
	3	43T46492	COIL, VALVE, 2WAY	4	6		
	3	43T46493	COIL, VALVE, 2WAY			4	6
	4	43T46476	MOTOR, PMV	4	6	4	6
△	5	43T50347	SENSOR, TCS	4	6	4	6
	6	43T19333	FIX-P-SENSOR	4	6	4	6
	7	43T70317	ASM-HOSE	1	1	1	1
	8	43T83313	HOSE-BAND	2	2	2	2
△	9	43T60435	SERV-TERMINAL	1	1	1	1
△	10	43T60460	TERMINAL, 2P	8	12	8	12
	11	43T60037	CLAMP-FILTER	4	6	4	6
	12	43T96310	BUSHING	1	1	1	1
	13	43T96309	BUSHING	4	6	4	6
	14	43T72327	DRAIN PAN ASSY	1		1	
	14	43T72328	DRAIN PAN ASSY		1		1

△ means highly important parts to maintain product safety.

16-4. Single port FS unit

RBM-Y1123FE/FE2, RBM-Y1803FE/FE2

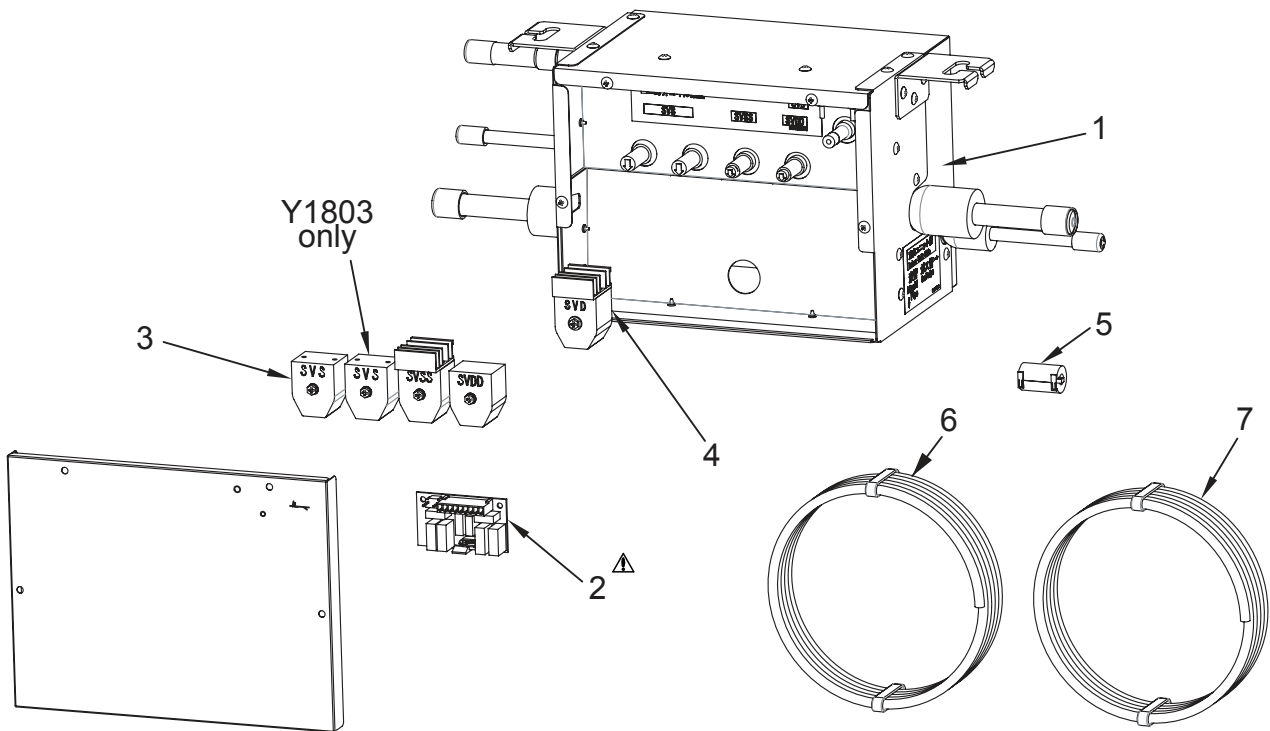

△	Location No.	Part No.	Description	RBM-Y1123		RBM-Y1803	
				FE	FE2	FE	FE2
	1	43149438	BODY ASSY, SERVICE			1	
	1	43149439	BODY ASSY, SERVICE	1			
	1	43149444	BODY ASSY, SERVICE				1
	1	43149445	BODY ASSY, SERVICE		1		
△	2	4316V238	PC BOARD ASSY, MCC-1431	1	1	1	1
	3	37546847	COIL, SOLENOID, VPV-MOAJ510B0	3		4	
	3	43146716	COIL, SOLENOID, VPV-MOAJ1843A0		3		4
	4	4314N123	2WAY, COIL, ASSY	1		1	
	4	4314N124	2WAY, COIL, ASSY		1		1
	5	43F60029	FILTER, NOISE	1	1	1	1
	6	43135011	CABLE ASSY, POWER	1	1	1	1
	7	43135012	CABLE ASSY	1	1	1	1

△ means highly important parts to maintain product safety.

RBM-Y2803FE/FE2

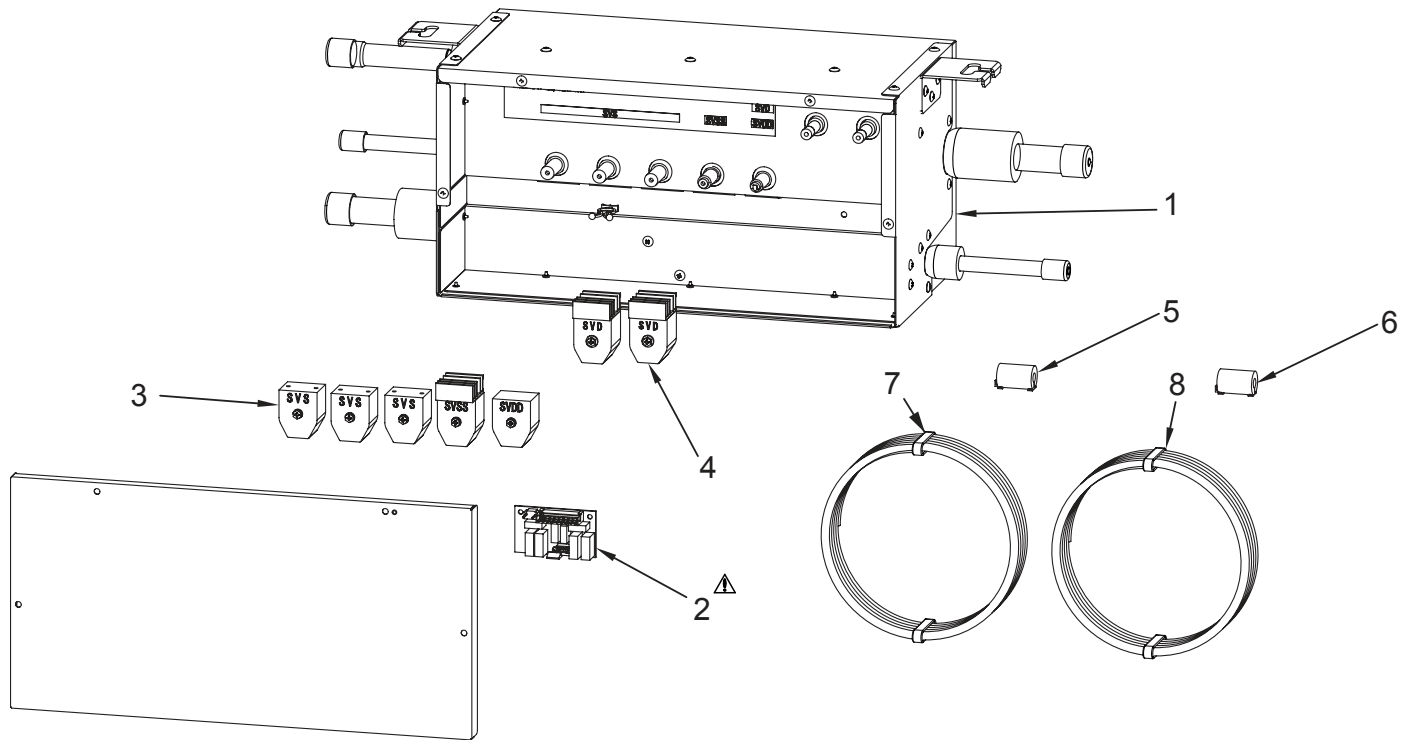

⚠	Location No.	Part No.	Description	RBM-Y2803	
				FE	FE2
	1	43149440	BODY ASSY, SERVICE	1	
	1	43149446	BODY ASSY, SERVICE		1
⚠	2	4316V238	PC BOARD ASSY, MCC-1431	1	1
	3	37546847	COIL, SOLENOID, VPV-MOAJ510B0	5	
	3	43146716	COIL, SOLENOID, 2WAY		5
	4	4314N123	2WAY,COIL, ASSY	2	
	4	4314N124	2WAY,COIL, ASSY		2
	5	43F60029	FILTER, NOISE	1	1
	6	43160563	FILTER, NOISE	1	1
	7	43135013	CABLE ASSY, POWER	1	1
	8	43135014	CABLE ASSY	1	1

⚠ means highly important parts to maintain product safety.

16-5 Single port FS unit (Long piping model)
 RBM-Y1124FE, RBM-Y1804FE, RBM-Y2804FE

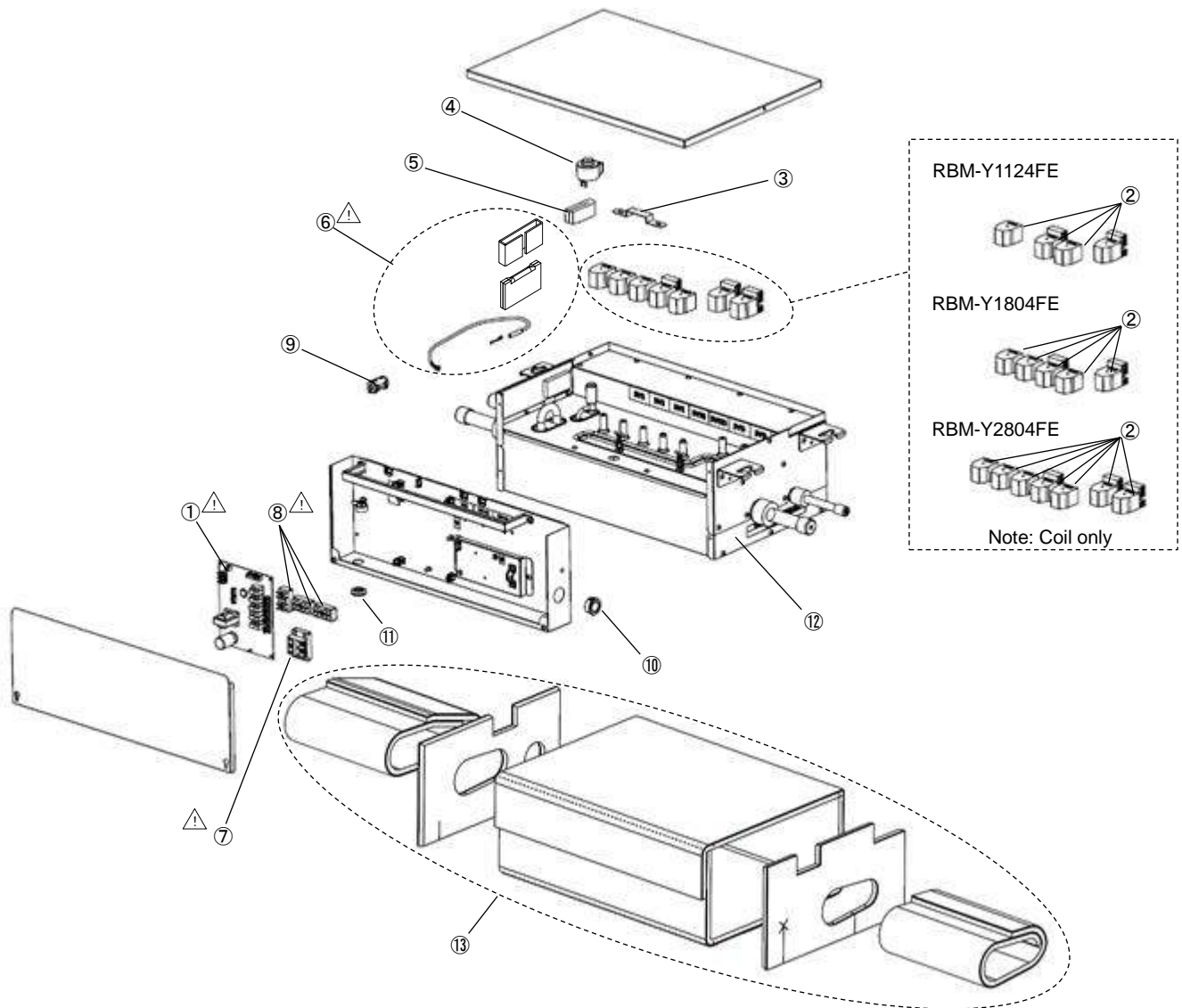

⚠	Location No.	Part No.	Description	RBM-Y1124FE	RBM-Y1804FE	RBM-Y2804FE
⚠	1	4316V615	PC BOARD ASSY	1	1	1
	2	4314N038	COIL, SOLENOID, AC220-240 50HZ	4	5	7
	3	43119537	PLATE, CONNECTION COIL	1	1	1
	4	4314N149	COIL, PMV	1	1	1
	5	43111373	INSULATOR, PMV	1	1	1
⚠	6	43150382	SENSOR, ASSY, TCS	1	1	1
⚠	7	43160575	TERMINAL BLOCK, 2P, 20A	1	1	1
⚠	8	43160467	TERMINAL, 2P	1	2	3
	9	43F60029	FILTER, NOISE	2	2	2
	10	43196114	BUSHING	1	1	1
	11	43007101	BUSHING	1	1	1
	12	43149447	BODY ASSY, SERVICE	1		
	12	43149448	BODY ASSY, SERVICE		1	
	12	43149449	BODY ASSY, SERVICE			1
	13	43111374	INSULATOR, SOUND ASSY	1	1	
	13	43111375	INSULATOR, SOUND ASSY			1

⚠ means highly important parts to maintain product safety.

No.13 : Refer to the section "Sound proof measure for Single port FS unit (Long piping model)".

RBM-Y1124FE2, RBM-Y1804FE2, RBM-Y2804FE2

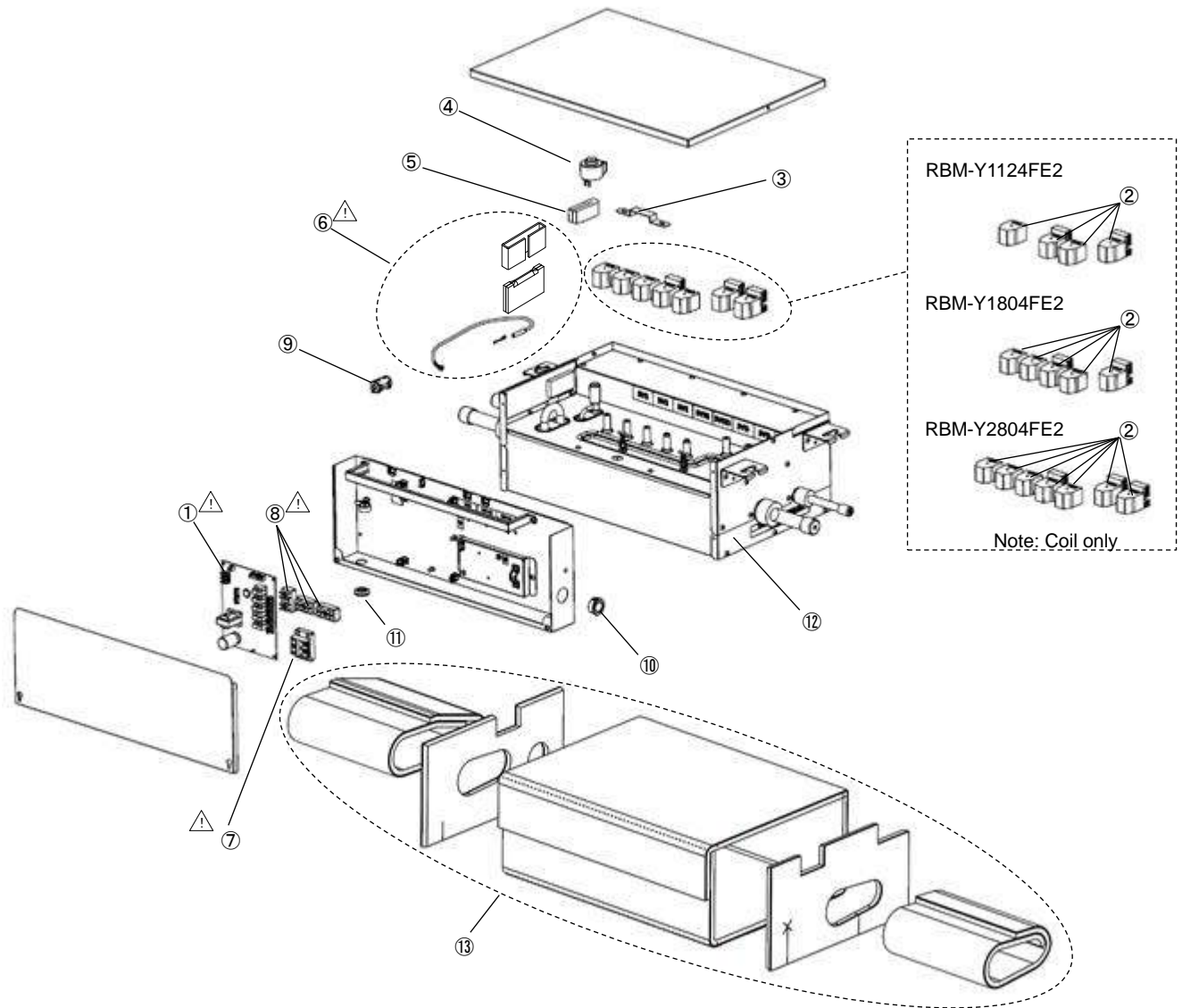

⚠	Location No.	Part No.	Description	RBM-Y1124FE2	RBM-Y1804FE2	RBM-Y2804FE2
⚠	1	4316V615	PC BOARD ASSY	1	1	1
	2	4314N046	COIL, SOLENOID, AC208-230V 60HZ	4	5	7
	3	43119537	PLATE, CONNECTION COIL	1	1	1
	4	4314N149	COIL, PMV	1	1	1
	5	43111373	INSULATOR, PMV	1	1	1
⚠	6	43150382	SENSOR, ASSY, TCS	1	1	1
⚠	7	43160575	TERMINAL BLOCK, 2P, 20A	1	1	1
⚠	8	43160467	TERMINAL, 2P	1	2	3
	9	43F60029	FILTER, NOISE	2	2	2
	10	43196114	BUSHING	1	1	1
	11	43007101	BUSHING	1	1	1
	12	43149447	BODY ASSY, SERVICE	1		
	12	43149448	BODY ASSY, SERVICE		1	
	12	43149449	BODY ASSY, SERVICE			1
	13	43111374	INSULATOR, SOUND ASSY	1	1	
	13	43111375	INSULATOR, SOUND ASSY			1

⚠ Means highly important parts to maintain product safety.

No.13 : Refer to the section "Sound proof measure for Single port FS unit (Long piping model)".

WARNINGS ON REFRIGERANT LEAKAGE

Check of Concentration Limit

The room in which the air conditioner is to be installed requires a design that in the event of refrigerant gas leaking out, its concentration will not exceed a set limit. The refrigerant R410A which is used in the air conditioner is safe, without the toxicity or combustibility of ammonia, and is not restricted by laws to be imposed which protect the ozone layer. However, since it contains more than air, it poses the risk of suffocation if its concentration should rise excessively. Suffocation from leakage of R410A is almost non-existent. With the recent increase in the number of high concentration buildings, however, the installation of multi air conditioner systems is on the increase because of the need for effective use of floor space, individual control, energy conservation by curtailing heat and carrying power etc. Most importantly, the multi air conditioner system is able to replenish a large amount of refrigerant compared with conventional individual air conditioners. If a single unit of the multi conditioner system is to be installed in a small room, select a suitable model and installation procedure so that if the refrigerant accidentally leaks out, its concentration does not reach the limit (and in the event of an emergency, measures can be made before injury can occur). In a room where the concentration may exceed the limit, create an opening with adjacent rooms, or install mechanical ventilation combined with a gas leak detection device. The concentration is as given below.

$$\frac{\text{Total amount of refrigerant (kg)}}{\text{Min. volume of the indoor unit installed room (m}^3\text{)}} \leq \text{Concentration limit (kg/m}^3\text{)}$$

The concentration limit of R410A which is used in multi air conditioners is 0.3kg/m³.

NOTE 1 :

If there are 2 or more refrigerating systems in a single refrigerating device, the amounts of refrigerant should be as charged in each independent device.

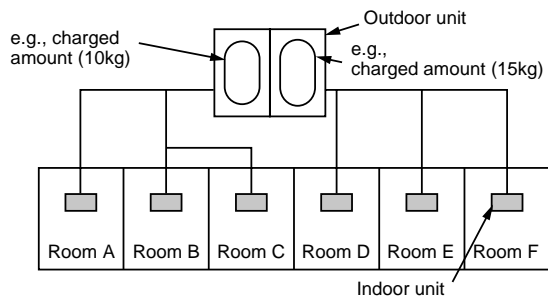

For the amount of charge in this example:
 The possible amount of leaked refrigerant gas in rooms A, B and C is 10kg.
 The possible amount of leaked refrigerant gas in rooms D, E and F is 15kg.

Important

NOTE 2 :

The standards for minimum room volume are as follows.

- (1) No partition (shaded portion)

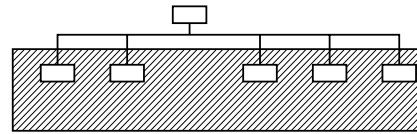

- (2) When there is an effective opening with the adjacent room for ventilation of leaking refrigerant gas (opening without a door, or an opening 0.15% or larger than the respective floor spaces at the top or bottom of the door).

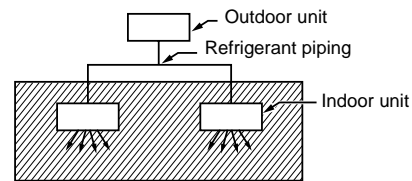

- (3) If an indoor unit is installed in each partitioned room and the refrigerant piping is interconnected, the smallest room of course becomes the object. But when a mechanical ventilation is installed interlocked with a gas leakage detector in the smallest room where the density limit is exceeded, the volume of the next smallest room becomes the object.

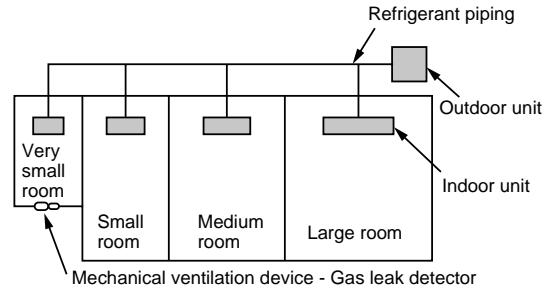

NOTE 3 :

The minimum indoor floor area compared with the amount of refrigerant is roughly as follows:
 (When the ceiling is 2.7m high)

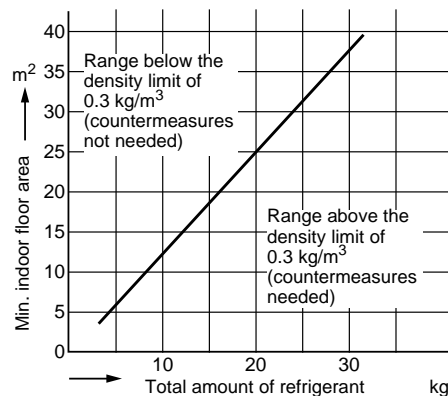

TOSHIBA CARRIER (THAILAND) CO.,LTD.

144 / 9 Moo 5, Bangkadi Industrial Park, Tivanon Road, Amphur Muang, Pathumthani 12000, Thailand